Section 01: Specifications

**Illustrations & Data for
All VMC Models**



(This page intentionally left blank).

VMC TRM

Use to lift by crane.
Insert shipping bar
attach to hook with lifting straps

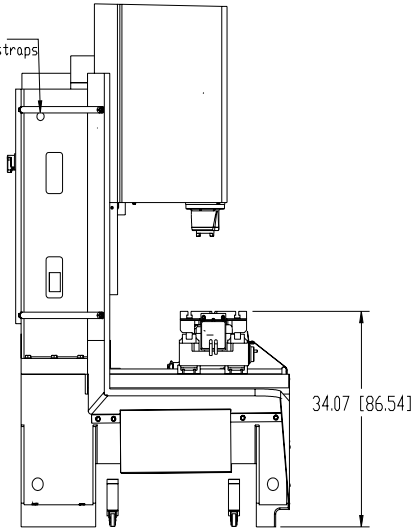

SIDE VIEW

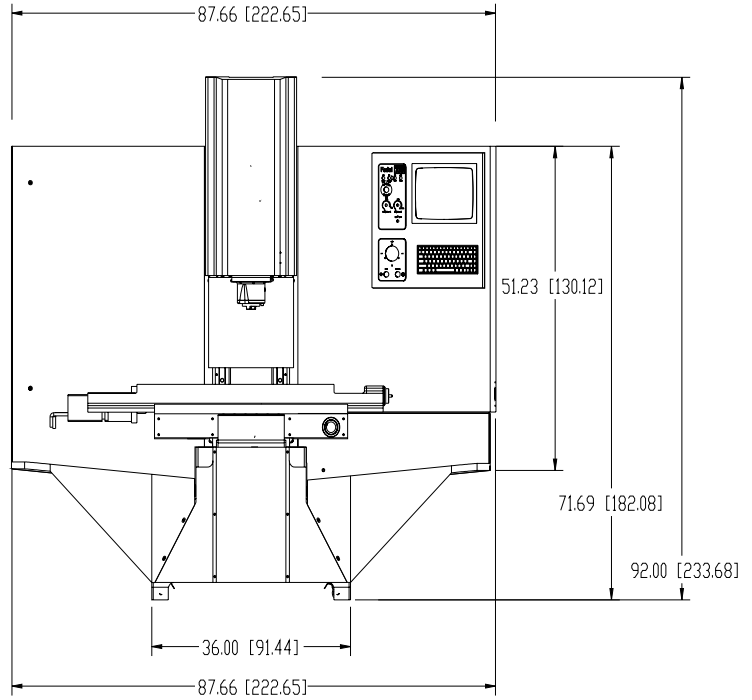

FRONT VIEW

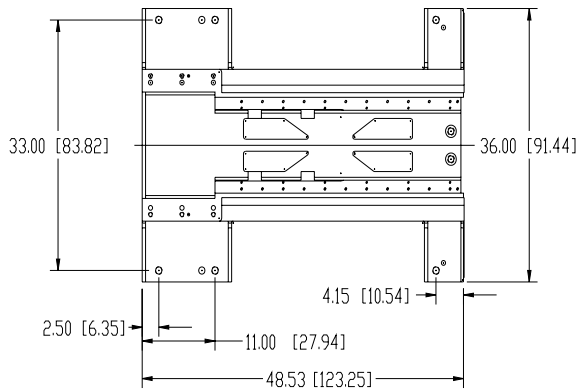

**TOP VIEW
BASE**

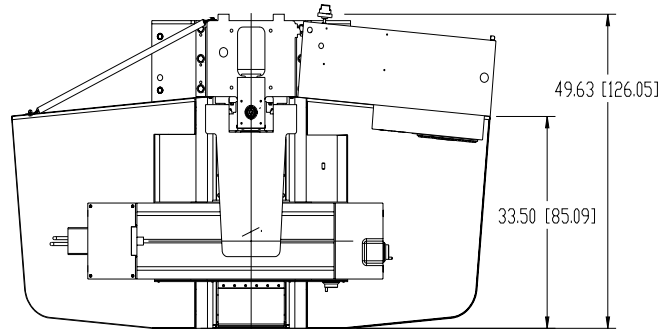

TOP VIEW

Note: Dimensions represented in inches & [centimeters]

Figure 1-1 VMC TRM

Table 1: VMC TRM Specifications

TRM Specifications	TRM Standard	TRM Metric
Table Size	35" x 12"	889mm x 304.8mm
Floor to Table	34.5"	876.3mm
T-Slots (No. x Width x Span)	3 x .562" x 4.375"	3 x 14.3mm x 111mm
Cutting Feed Rate	.01-200" ipm	.25-5080 mm/min
Rapid Feed Rate (X/Y/Z)	200 ipm	5080 mm/min
Max. Weight on Table	500 lbs	226.8 kg.
Axis Drive Motor (X/Y/Z)	DC, 2,000 lbs*	
Ball Screw Size	32mm	
Longitudinal (X Axis)	30"	762mm
Cross (Y Axis)	14"	355.6mm
Vertical (Z Axis)	14"	355.6mm
Spindle Nose to Table	4"-18"	101.6mm-457.2mm
Spindle Center to Column Ways	19"	482.6mm
Main Motor HP	5 HP*	
Opt. HT Motor - Automatic 2 Speed Vector	N/A	
Torque	28 ft-lbs*	38Nm
Accuracy, Axis Positioning	± .0004"***	.0102mm
Accuracy, Axis Repeatability	± .0002"***	.0050mm
Glass Scales (X/Y/Z)	N/A	
Spindle Speed	4,000 rpm	
Spindle Orientation	N/A	
Spindle Taper	No. 40	
Max. Tool Diameter	4.5"	114.3mm
Max. Tool Length	10"	254mm
Max. Tool Weight	15 lbs.	6.8kg
Machine Width and Depth	88" W x 50" D	2235mm x 1270mm
Machine Maximum Height	92"	2336.8mm
Machine Weight	3,500 lbs.	1587kg
Air Pressure Reqs. (Momentary)	80-120 psi, 15 scfm	
Power Reqs. (3-phase)	22 amps, 220 VAC	
Single Phase (Optional)	45 amps, 220 VAC	

* Rated Peak Value

**All accuracies are quoted at 68 F

VMC EMC

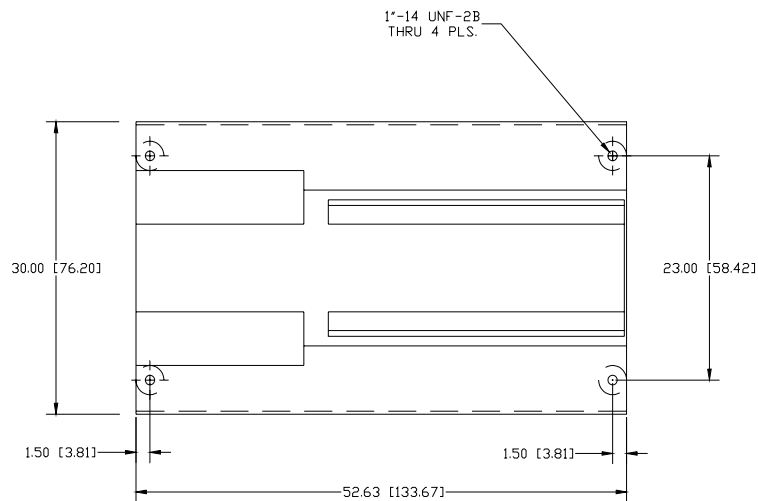
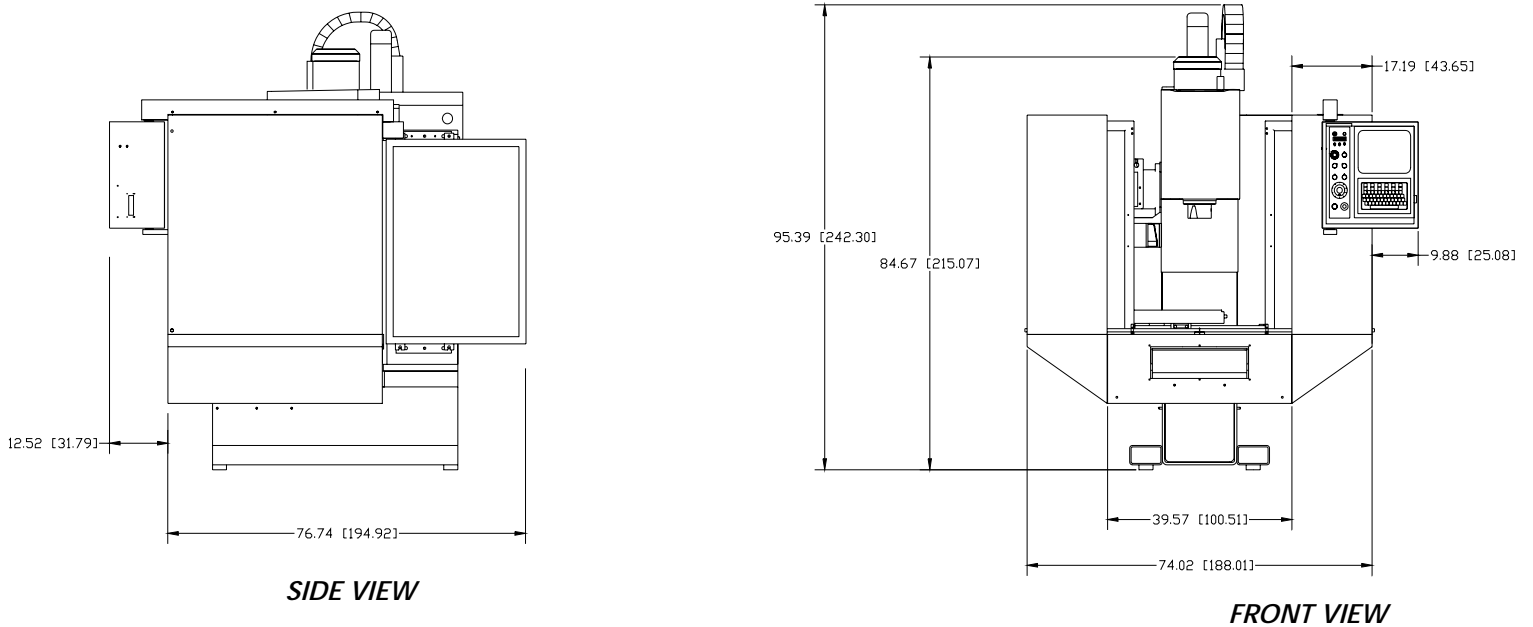

Figure 1-2 VMC EMC

TOP VIEW
BASE
SCALE 2:1

Note: Dimensions represented in inches & [centimeters]

Table 2: VMC EMC Specifications

EMC Specifications	EMC Standard	EMC Metric
Table Size	29.5" x 16"	749mm x 406mm
Floor to Table	33.25"	845mm
T-Slots (No. x Width x Span)	3 x .562" x 4.33"	3 x 14mm x 110mm
Cutting Feed Rate	.01-250" ipm (375 @ 150%)	.25-6,350 (9,525 at 150%) mm/min
Rapid Feed Rate (X/Y/Z)	700 ipm	17.8 m/min
Max. Weight on Table	1,000 lbs	453.6 kg
Axis Drive Motor (X/Y/Z)	DC, 2,500 lbs	AC, 11,250 N*thrust
Ball Screw Size		32 mm
Longitudinal (X Axis)	20"	508mm
Cross (Y Axis)	16"	406mm
Vertical (Z Axis)	14"	356mm
Spindle Nose to Table	4"-18"	102mm-457mm
Spindle Center to Column Ways	17"	431mm
Main Motor - Automatic 2 Speed Vector	12 HP*	
Opt. HT Motor - Automatic 2 Speed Vector	N/A	
Torque	36 ft-lbs	102Nm
Accuracy, Axis Positioning	± .0002"	.0050mm
Accuracy, Axis Repeatability	± .0001"	.0025mm
Glass Scales (X/Y/Z)	N/A	
Spindle Speed	7,500 rpm	
Spindle Orientation	Electromechanical	
Spindle Taper	No. 40	
ATC, Number of Tools	16	
ATC, Tool Selection	Random, Bi-directional	
Max. Tool Diameter	3"	76mm
Max. Tool Length	10"	381mm
Max. Tool Weight	15 lbs.	6.8kg
Machine Width and Depth	75" W x 77" D	1.9mm x 2.0mm
Machine Maximum Height	92"	2.6m
Machine Weight	4,800 lbs.	2495kg
Air Pressure Reqs. (Momentary)	80-120 psi, 15 scfm	5.5 Bar
Power Reqs. (3-phase)	40 amps, 230 VAC	
Single Phase (Optional)	60 amps, 230 VAC	
Cool Power System	N/A	
Ball Screw Supports (X/Y/Z)	dual	
No. of Ground Boxways per Axis (X/Y/Z)		

*Rated Peak Value

VMC 15/15XT

Use to lift by Crane. Insert shipping bar
attach to hook with lifting straps

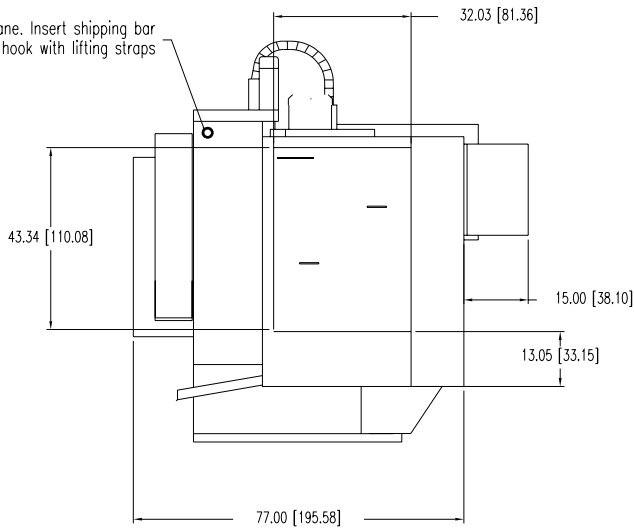

SIDE VIEW

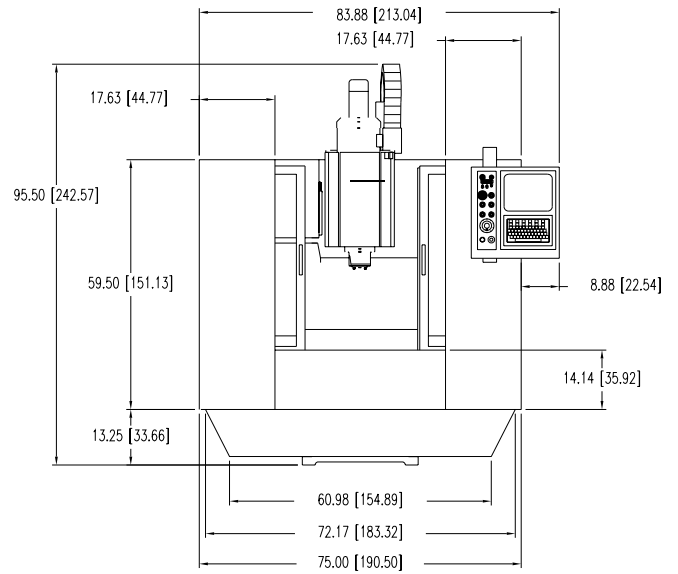

FRONT VIEW

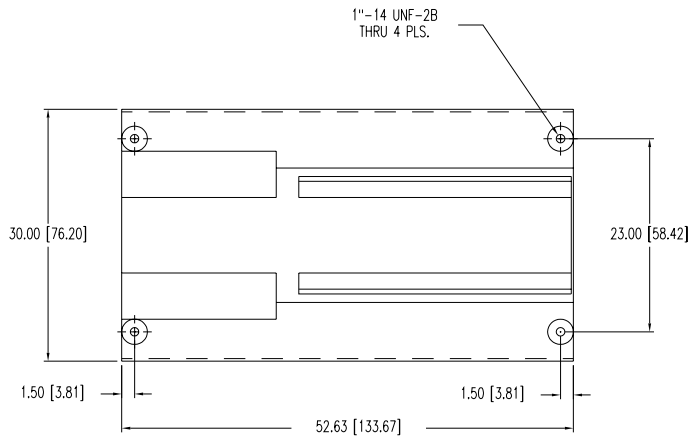

**TOP VIEW
BASE
SCALE 2:1**

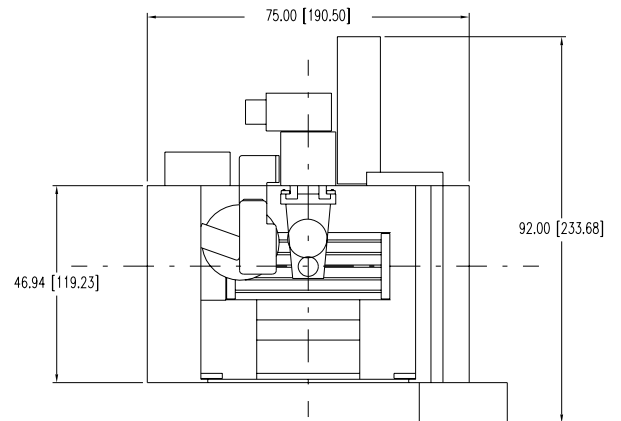

TOP VIEW

Note: Dimensions represented in inches & [centimeters]

Figure 1-3 VMC 15, 15XT

Table 1: VMC 15 Specifications

15 Specifications	15 Standard	15 Metric
Table Size	29.5" x 16"	749mm x 406mm
Floor to Table	30.5"	775mm
T-Slots (No. x Width x Span)	3 x .562" x 4.33"	3 x 14mm x 110mm
Cutting Feed Rate	.01-250" ipm (375 @ 150%)	.25-6,350 (9,525 at 150%) mm/min
Rapid Feed Rate (X/Y/Z)	400 ipm	10.1 m/min
Max. Weight on Table	1,500 lbs	680 kg
Axis Drive Motor (X/Y/Z)	DC, 3,500 lbs	AC, 15,900 N*thrust
Ball Screw Size	31.75mm Dia.	
Longitudinal (X Axis)	20"	508mm
Cross (Y Axis)	16"	406mm
Vertical (Z Axis)	20" (28" Opt.)	508mm (711mm Opt.)
Spindle Nose to Table	4"-24" (4"-32" Opt.)	102mm-610mm (102-813mm)
Spindle Center to Column Ways	17"	431mm
Main Motor - Automatic 2 Speed Vector	15 HP*, 11.2 KW	
Opt. HT Motor - Automatic 2 Speed Vector	N/A	
Torque	75 ft-lbs	102Nm
Accuracy, Axis Positioning	± .0002"	.0050mm
Accuracy, Axis Repeatability	± .0001"	.0025mm
Glass Scales (X/Y/Z)	N/A	
Spindle Speed	10-7,500 rpm	
Spindle Orientation	Electromechanical	
Spindle Taper	No. 40	
ATC, Number of Tools	21	
ATC, Tool Selection	Random, Bi-directional	
Max. Tool Diameter	3"	76mm
Max. Tool Length	15"	381mm
Max. Tool Weight	15 lbs.	6.8kg
Machine Width and Depth	75" W x 77" D	1.9mm x 2.0mm
Machine Maximum Height	101"	2.6m
Machine Weight	5,500 lbs.	2495kg
Air Pressure Reqs. (Momentary)	120 psi, 15 scfm	5.5 Bar
Power Reqs. (3-phase)	40/45 amps, 230 VAC	
Single Phase (Optional)	60 amps, 230 VAC	
Cool Power System	N/A	
Ball Screw Supports (X/Y/Z)	dual	
No. of Ground Boxways per Axis (X/Y/Z)		

*Rated Peak Value

Table 2: VMC 15XT Specifications

15XT Specifications	15XT Standard	15XT Metric
Table Size	38" x 16 "	965mm x 406mm
Floor to Table	30.5"	775mm
T-Slots (No. x Width x Span)	3 x .562" x 4.33"	3 x 14mm x 110mm
Cutting Feed Rate	.01-250" ipm (375 @ 150%)	.25-6,350 (9,525 at 150%) mm/min
Rapid Feed Rate (X/Y/Z)	400 ipm	10.1 m/min
Max. Weight on Table	1,500 lbs	680 kg
Axis Drive Motor (X/Y/Z)	DC, 3,500 lbs	AC,15,900 N*thrust
Ball Screw Size	31.75mm Dia.	
Longitudinal (X Axis)	30"	762mm
Cross (Y Axis)	16"	406mm
Vertical (Z Axis)	20" (28" Opt.)	508mm (711mm Opt.)
Spindle Nose to Table	4"-24" (4"-32" Opt.)	102mm-610mm (102-813mm)
Spindle Center to Column Ways	17"	431mm
Main Motor - Automatic 2 Speed Vector	15 HP*, 11.2 KW	
Opt. HT Motor - Automatic 2 Speed Vector	N/A	
Torque	75 ft-lbs	102 Nm
Accuracy, Axis Positioning	± .0002"	.0050mm
Accuracy, Axis Repeatability	± .0001"	.0025mm
Glass Scales (X/Y/Z)	N/A	
Spindle Speed	10-7,500 rpm	
Spindle Orientation	Electromechanical	
Spindle Taper	No. 40	
ATC, Number of Tools	21	
ATC, Tool Selection	Random, Bi-directional	
Max. Tool Diameter	3"	76mm
Max. Tool Length	15"	381mm
Max. Tool Weight	15 lbs.	6.8kg
Machine Width and Depth	75" W x 77" D	1.9mm x 2mm
Machine Maximum Height	101"	2.6mm
Machine Weight	5,800 lbs.	2495kg
Air Pressure Reqs. (Momentary)	120 psi, 15 scfm	5.5 Bar
Power Reqs. (3-phase)	40/45 amps, 230 VAC	
Single Phase (Optional)	60 amps, 230 VAC	
Cool Power System	N/A	
Ball Screw Supports (X/Y/Z)	dual	
No. of Ground Boxways per Axis (X/Y/Z)		

*Rated Peak Value

VMC 2216

Use to lift by Crane.
Insert shipping bar.
Attach to hook with lifting straps.

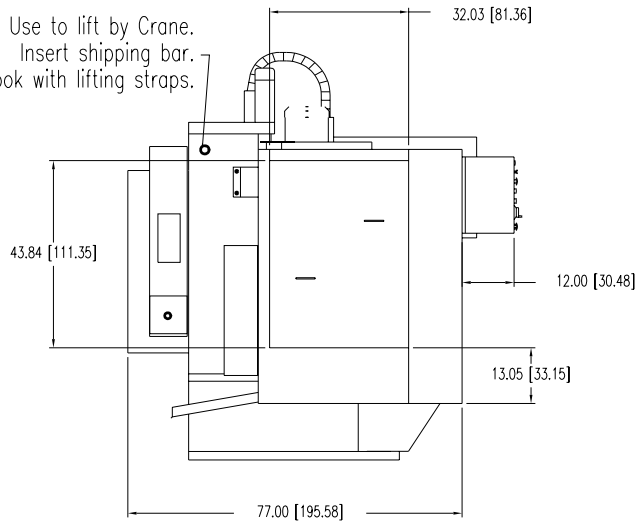

SIDE VIEW

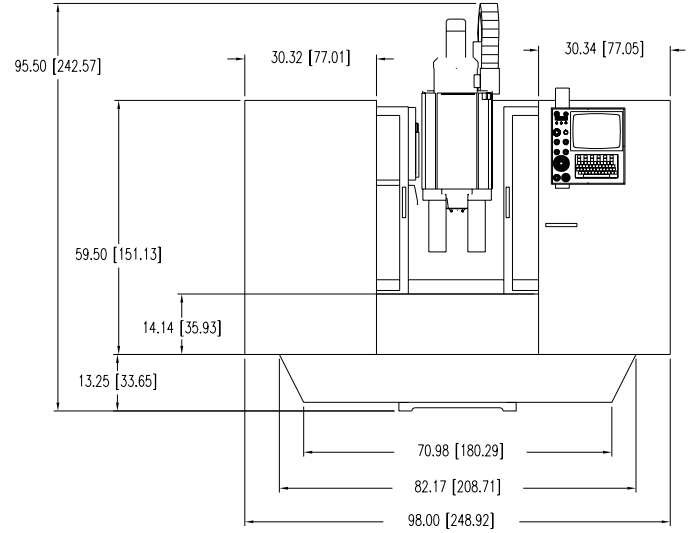

FRONT VIEW

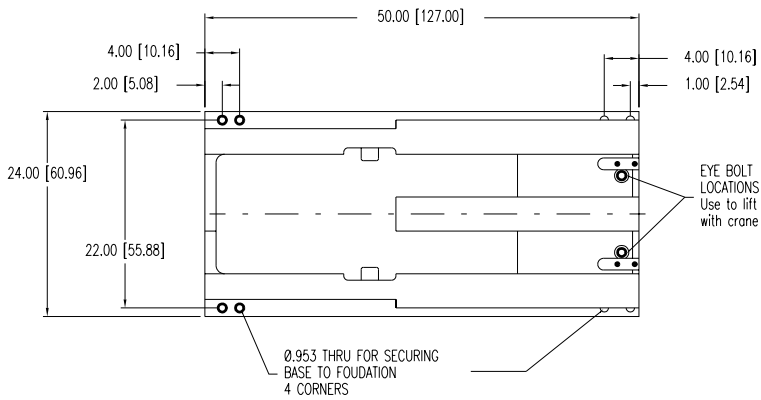

**TOP VIEW
BASE
SCALE 2:1**

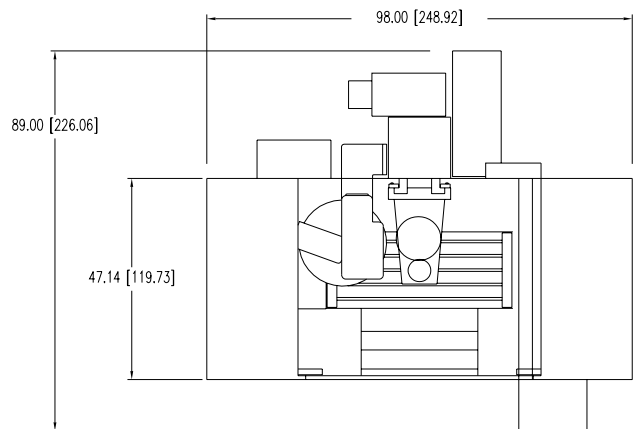

TOP VIEW

Figure 1-4 VMC 2216

Note: Dimensions represented in inches & [centimeters]

Table 2: VMC 2216 Specifications

2216 Specifications	2216 Standard	2216 Metric
Table Size	39" x 16"	750mm x 406mm
Floor to Table	31"	787mm
T-Slots (No. x Width x Span)	3 x .562" x 4.33"	3 x 14mm x 110mm
Cutting Feed Rate	.01-400 ipm (600 @ 150%)	.25-10,160 (15,240 at 150%)mm/min.
Rapid Feed Rate (X/Y/Z)	900 ipm (X/Y) 700 ipm (Z)	22.8 m/min. (X,Y) 17.7 m/min (Z)
Max. Weight on Table	2,006 lbs.	991 kg.
Axis Drive Motor (X/Y/Z)*	AC, 3,800 lbs	AC, 16.900 N* thrust
Ball Screw Size	40mm Dia. (X/Y/Z)	
Longitudinal (X Axis)	22"	559mm
Cross (Y Axis)	16"	406mm
Vertical (Z Axis)	20" (28" Opt.)	508mm (711mm Opt.)
Spindle Nose to Table	4"-24" (4"-32" Opt.)	102mm-610mm (102mm-813mm)
Spindle Center to Column Ways	16"	406mm
Main Motor - Automatic 2 Speed Vector	15 HP*, 11.2 KW	
Opt. HT Motor - Automatic 2 Speed Vector	22.5 HP*, 16.8 KW	
Torque	160 ft-lbs, 220 ft-lbs (HT)	220 Nm/300 Nm
Accuracy, Axis Positioning	± .0002"	.0050mm
Accuracy, Axis Repeatability	± .0001"	.0025mm
Glass Scales (X/Y/Z)	Optional	
Spindle Speed	10-10,000 rpm (15,000 Opt.)	
Spindle Orientation	Electromechanical	
Spindle Taper	No. 40	
ATC, Number of Tools	21	
ATC, Tool Selection	Random, Bi-directional	
Max. Tool Diameter	3" (4.5" w/o adjacent tools)	76mm (114mm w/o adjacent tools)
Max. Tool Length	15"	381
Max. Tool Weight	15 lbs.	6.8 kg
Machine Width and Depth	98" W x 77" D	2.5m W x 2m D
Machine Maximum Height	103"	2.6m
Machine Weight	8,300 lbs.	3,765 kg
Air Pressure Reqs. (Momentary)	120 psi, 15 scfm	5.5 Bar
Power Reqs. (3-phase)	40/45 amps, 230 VAC	
Single Phase (Optional)	60 amps, 230 VAC	
Cool Power System	Spindle, Headstock, Ballscrews	
Ball Screw Supports (X/Y/Z)	dual	
No. of Ground Boxways per Axis (X/Y/Z)	2	

* Rated Peak Value

VMC 3016

Use to lift by Crane.
Insert shipping bar.
Attach to hook with lifting straps.

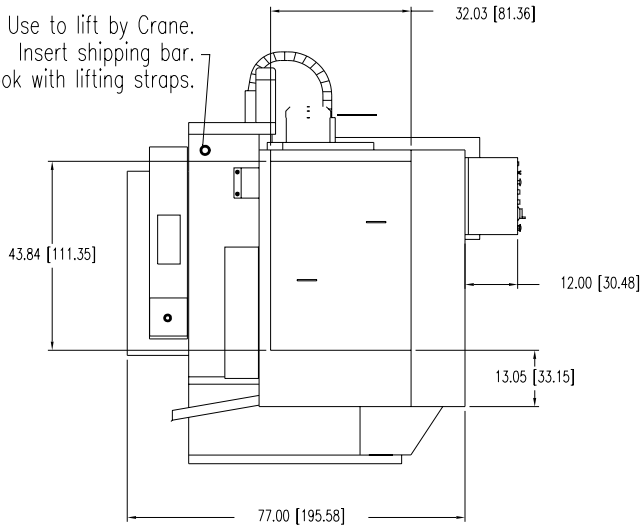

SIDE VIEW

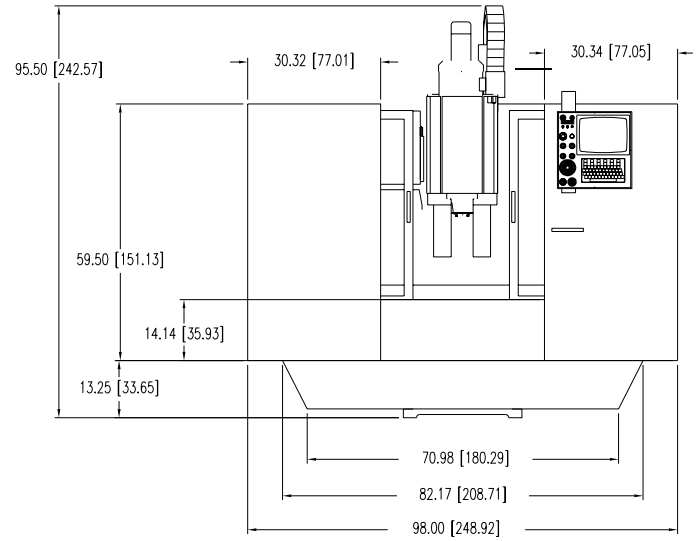

FRONT VIEW

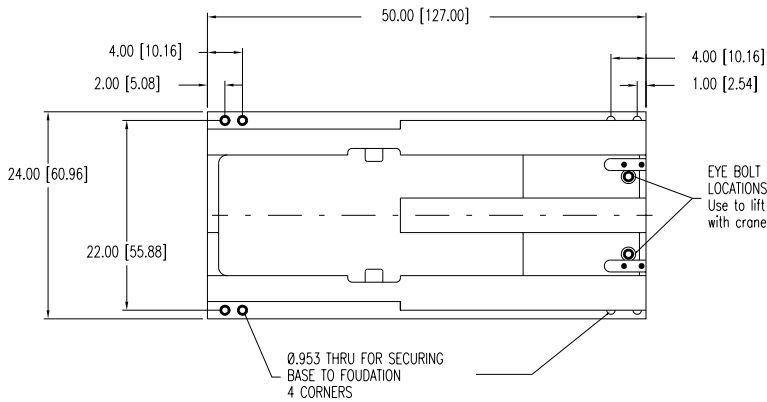

**TOP VIEW
BASE
SCALE 2:1**

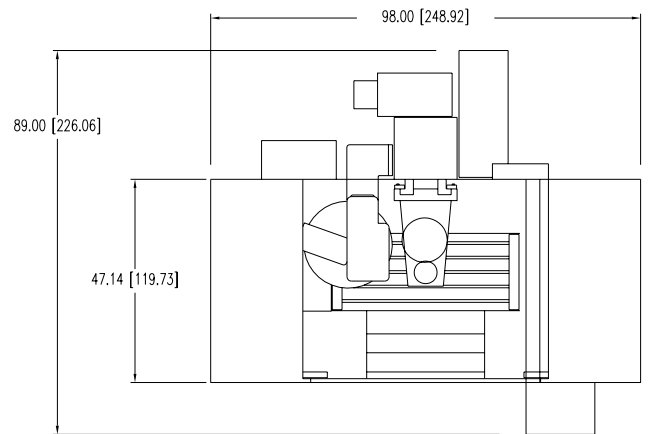

TOP VIEW

Figure 1-5 VMC 3016

Note: Dimensions represented in inches & [centimeters]

Table 3: VMC 3016 Specifications

3016 Specifications	3016 Standard	3016 Metric
Table Size	39" x 16"	750mm x 406mm
Floor to Table	31"	787mm
T-Slots (No. x Width x Span)	3 x .562" x 4.33"	3 x 14mm x 110mm
Cutting Feed Rate	.01-400 ipm (600 @ 150%)	.25-10,160 (15,240 at 150%)mm/min.
Rapid Feed Rate (X/Y/Z)	900 ipm (X/Y) 700 ipm (Z)	22.8 m/min. (X,Y) 17.7 m/min (Z)
Max. Weight on Table	2,736 lbs.	1,241 kg.
Axis Drive Motor (X/Y/Z)	AC, 3,800 lbs peak thrust	AC, 16.900 N* thrust
Ball Screw Size	40mm Dia. (X/Y/Z)	
Longitudinal (X Axis)	30"	762mm
Cross (Y Axis)	16"	406mm
Vertical (Z Axis)	20" (28" Opt.)	508mm (711mm Opt.)
Spindle Nose to Table	4"-24" (4"-32" Opt.)	102mm-610mm (102mm-813mm)
Spindle Center to Column Ways	16"	406mm
Main Motor - Automatic 2 Speed Vector	15 HP*, 11.2 KW	
Opt. HT Motor - Automatic 2 Speed Vector	22.5 HP*, 16.8 KW	
Torque	160 ft-lbs, 220 ft-lbs (HT)	220 Nm/300 Nm
Accuracy, Axis Positioning	± .0002"	.0050mm
Accuracy, Axis Repeatability	± .0001"	.0025mm
Glass Scales (X/Y/Z)	Optional	
Spindle Speed	10-10,000 rpm (15,000 Opt.)	
Spindle Orientation	Electromechanical	
Spindle Taper	No. 40	
ATC, Number of Tools	21	
ATC, Tool Selection	Random, Bi-directional	
Max. Tool Diameter	3" (4.5" w/o adjacent tools)	76mm (114mm w/o adjacent tools)
Max. Tool Length	15"	381mm
Max. Tool Weight	15 lbs.	6.8 kg
Machine Width and Depth	98" W x 77" D	2.5m W x 2m D
Machine Maximum Height	103"	2.6m
Machine Weight	8,550 lbs.	3,878 kg
Air Pressure Reqs. (Momentary)	120 psi, 15 scfm	5.5 Bar
Power Reqs. (3-phase)	40/45 amps, 230 VAC (20/25 480 VAC)	
Single Phase (Optional)	60 amps, 230 VAC	
Cool Power System	Spindle, Headstock, Ballscrews	
Ball Screw Supports (X/Y/Z)	dual	
No. of Ground Boxways per Axis (X/Y/Z)	2	

* Rated Peak Value

VMC 2016L

Use to lift by Crane.
Insert shipping bar.
Attach to hook with lifting straps.

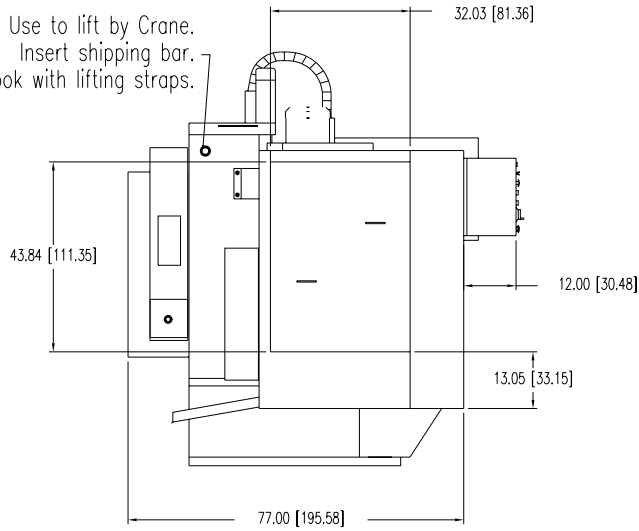

SIDE VIEW

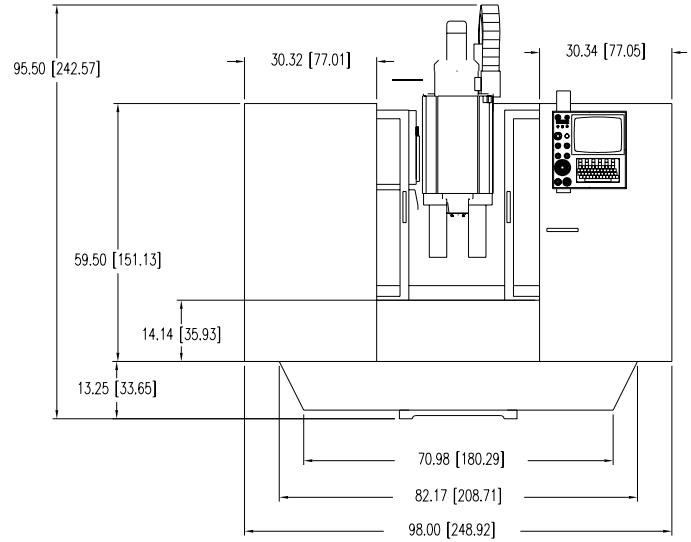

FRONT VIEW

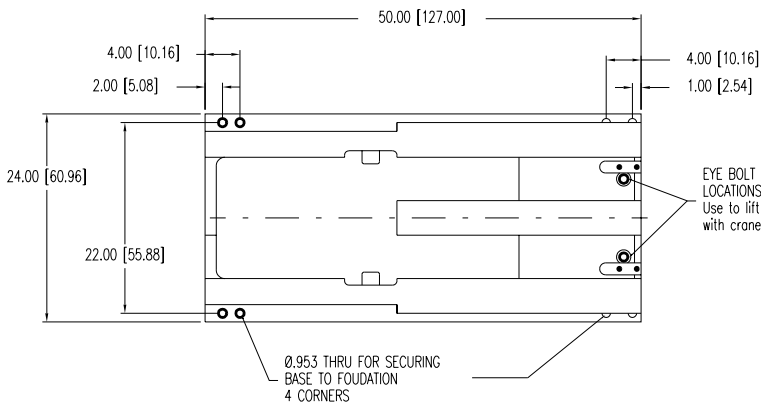

**TOP VIEW
BASE
SCALE 2:1**

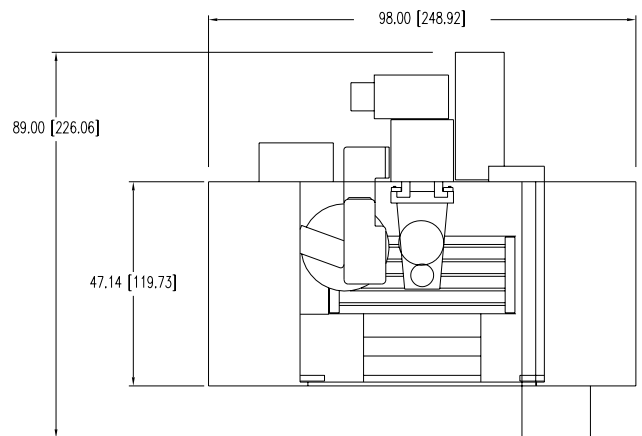

TOP VIEW

Figure 1-6 VMC 2016

Note: Dimensions represented in inches & [centimeters]

Table 4: VMC 2016L Specifications

2016L Specifications	2016L Standard	2016L Metric
Table Size	29.5" x 16"	750mm x 406mm
Floor to Table	30.5"	775mm
T-Slots (No. x Width x Span)	3 x .562" x 4.33"	3 x 14mm x 110mm
Cutting Feed Rate	.01-250 ipm (375 @ 150%)	.25-6,350 (9,525 at 150%)mm/min.
Rapid Feed Rate (X/Y/Z)	500 ipm (X/Y/Z)	12.7 m/min (X,Y,Z)
Max. Weight on Table	2,000 lbs.	907 kg.
Axis Drive Motor (X/Y/Z)	DC 3,500 lbs peak thrust	AC, 15,900 N* thrust
Ball Screw Size	31.75mm Dia. (X/Y/Z)	
Longitudinal (X Axis)	20"	508mm
Cross (Y Axis)	16"	406mm
Vertical (Z Axis)	20" (28" Opt.)	508mm (711mm Opt.)
Spindle Nose to Table	4"-24" (4"-32" Opt.)	102mm-610mm (102mm-813mm)
Spindle Center to Column Ways	17"	406mm
Main Motor - Automatic 2 Speed Vector	15 HP*, 11.2 KW	
Opt. HT Motor - Automatic 2 Speed Vector	N/A	
Torque	75 ft-lbs	102 Nm
Accuracy, Axis Positioning	± .0002"	.0050mm
Accuracy, Axis Repeatability	± .0001"	.0025mm
Glass Scales (X/Y/Z)	N/A	
Spindle Speed	10-7,500 rpm	
Spindle Orientation	Electromechanical	
Spindle Taper	No. 40	
ATC, Number of Tools	21	
ATC, Tool Selection	Random, Bi-directional	
Max. Tool Diameter	3" (4.5" w/o adjacent tools)	76mm (114mm w/o adjacent tools)
Max. Tool Length	15"	381mm
Max. Tool Weight	15 lbs.	6.8 kg
Machine Width and Depth	75" W x 77" D	1.91m W x 1.96m D
Machine Maximum Height	101"	2.6m
Machine Weight	5,800 lbs.	2,631 kg
Air Pressure Reqs. (Momentary)	120 psi, 15 scfm	5.5 Bar
Power Reqs. (3-phase)	40/45 amps, 230 VAC (20/25, 480 VAC)	
Single Phase (Optional)	60 amps, 230 VAC	
Cool Power System	N/A	
Ball Screw Supports (X/Y/Z)	dual	
No. of Ground Boxways per Axis (X/Y/Z)	N/A	

* Rated Peak Value

VMC 3016L

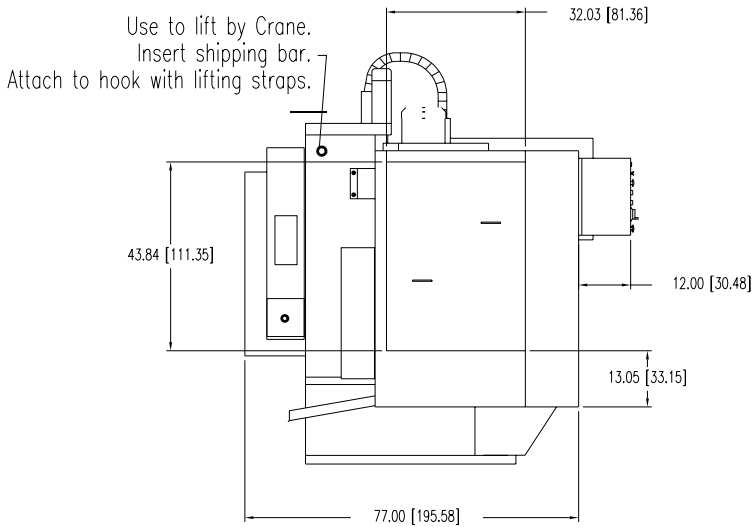

SIDE VIEW

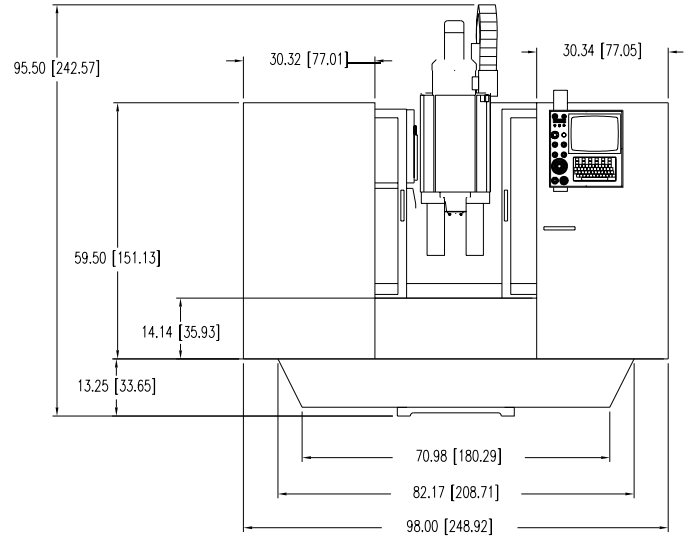

FRONT VIEW

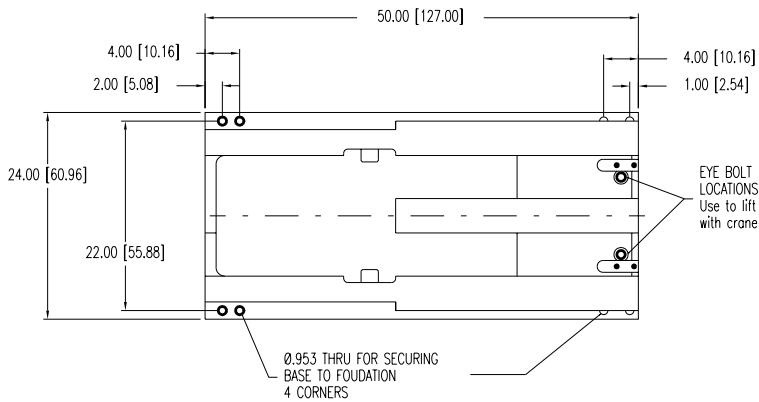

**TOP VIEW
BASE
SCALE 2:1**

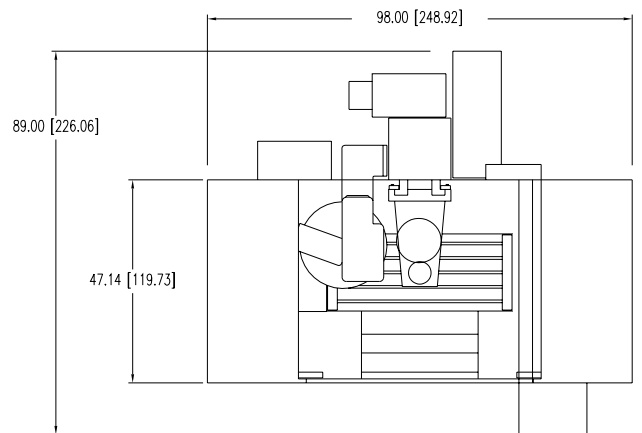

TOP VIEW

Figure 1-7 VMC 3016L

Note: Dimensions represented in inches & [centimeters]

Table 5: VMC 3016L Specifications

3016L Specifications	3016L Standard	3016L Metric
Table Size	38" x 16"	750mm x 406mm
Floor to Table	30.5"	775mm
T-Slots (No. x Width x Span)	3 x .562" x 4.33"	3 x 14mm x 110mm
Cutting Feed Rate	.01-250 ipm (375 @ 150%)	.25-6,350 (9,525 at 150%)mm/min.
Rapid Feed Rate (X/Y/Z)	500 ipm (X/Y/Z)	12.7 m/min (X,Y,Z)
Max. Weight on Table	2,000 lbs.	907 kg.
Axis Drive Motor (X/Y/Z)	DC 3,500 lbs peak thrust	AC, 15,900 N* thrust
Ball Screw Size	31.75mm Dia. (X/Y/Z)	
Longitudinal (X Axis)	30"	762mm
Cross (Y Axis)	16"	406mm
Vertical (Z Axis)	20" (28" Opt.)	508mm (711mm Opt.)
Spindle Nose to Table	4"-24" (4"-32" Opt.)	102mm-610mm (102mm-813mm)
Spindle Center to Column Ways	17"	406mm
Main Motor - Automatic 2 Speed Vector	15 HP*, 11.2 KW	
Opt. HT Motor - Automatic 2 Speed Vector	N/A	
Torque	75 ft-lbs	102 Nm
Accuracy, Axis Positioning	± .0002"	.0050mm
Accuracy, Axis Repeatability	± .0001"	.0025mm
Glass Scales (X/Y/Z)	N/A	
Spindle Speed	10-7,500 rpm	
Spindle Orientation	Electromechanical	
Spindle Taper	No. 40	
ATC, Number of Tools	21	
ATC, Tool Selection	Random, Bi-directional	
Max. Tool Diameter	3" (4.5" w/o adjacent tools)	76mm (114mm w/o adjacent tools)
Max. Tool Length	15"	381mm
Max. Tool Weight	15 lbs.	6.8 kg
Machine Width and Depth	90" W x 77" D	2.3m W x 1.96m D
Machine Maximum Height	101"	2.6m
Machine Weight	6,200 lbs	2812 kg
Air Pressure Reqs. (Momentary)	120 psi, 15 scfm	5.5 Bar
Power Reqs. (3-phase)	40/45 amps, 230 VAC (20/25, 480 VAC)	
Single Phase (Optional)	60 amps, 230 VAC	
Cool Power System	N/A	
Ball Screw Supports (X/Y/Z)	dual	
No. of Ground Boxways per Axis (X/Y/Z)	N/A	

* Rated Peak Value

VMC 4020

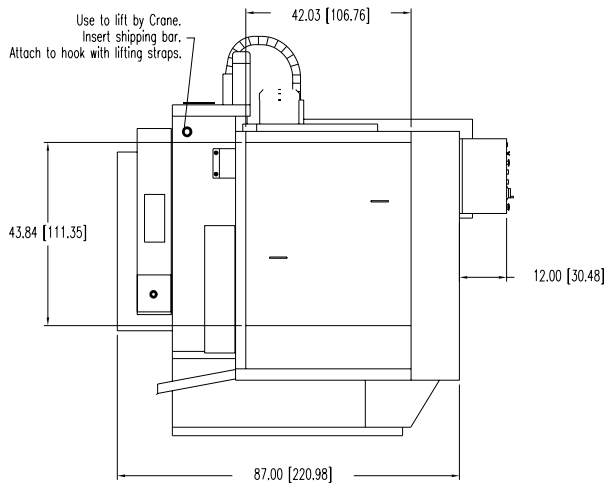

SIDE VIEW

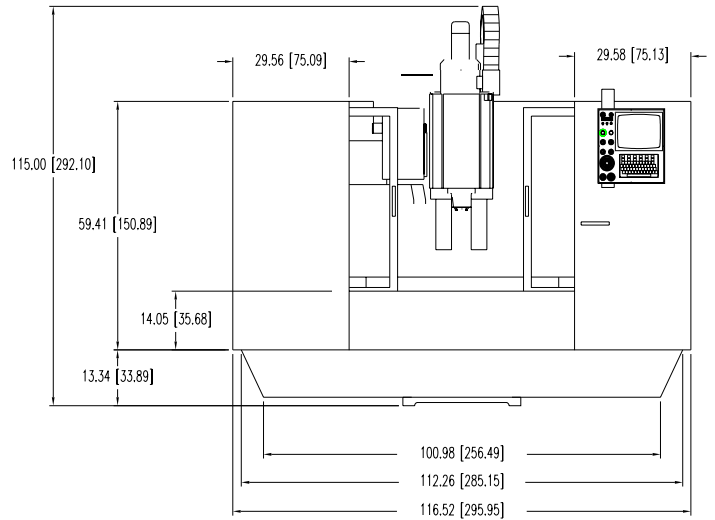

FRONT VIEW

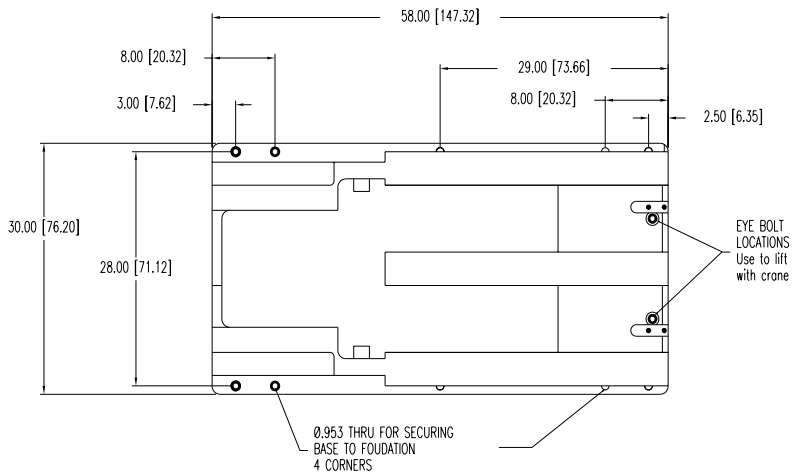

TOP VIEW
BASE
SCALE 2:1

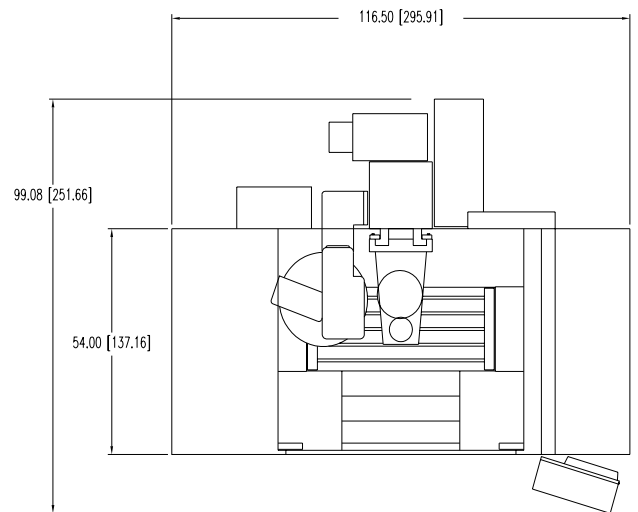

TOP VIEW

Figure 1-8 VMC 4020

Optional Very High Torque Motor 30 Peak Horsepower, 32 Amps continuous current in WYE mode, 56 Amps continuous current in DELTA mode, Peak current may run as high as 70 Amps

Note: Dimensions represented in inches & [centimeters]

Table 6: VMC 4020 Specifications

4020 Specifications	4020 Standard	4020 Metric
Table Size	48" x 20"	1,219mm x 508mm
Floor to Table	32"	813mm
T-Slots (No. x Width x Span)	5 x .687" x 3.75"	5 x 17.5mm x 95.3mm
Cutting Feed Rate	.01-400 ipm (600 @ 150%)	.25-10,160 (15,240 at 150%)mm/min.
Rapid Feed Rate (X/Y/Z)	900 ipm (X/Y) 700 ipm (Z)	22.8 m/min (X,Y,Z)
Max. Weight on Table	3,641 lbs.	1,652 kg.
Axis Drive Motor (X/Y/Z)	AC, 3,800 lbs peak thrust	AC, 16,900 N* thrust
Ball Screw Size	40mm Dia. (X/Y/Z)	
Longitudinal (X Axis)	40"	1,016mm
Cross (Y Axis)	20"	508mm
Vertical (Z Axis)	20" (28" Opt.)	508mm (711mm Opt.)
Spindle Nose to Table	4"-24" (4"-32" Opt.)	102mm-610mm (102mm-813mm)
Spindle Center to Column Ways	20"	406mm
Main Motor - Automatic 2 Speed Vector	15 HP*, 11.2 KW	
Opt. HT Motor - Automatic 2 Speed Vector	22.5 HP*, 16.8 KW	
Torque	160 ft-lbs, 220 ft-lbs (Opt.)	220 Nm/300Nm/378Nm
Accuracy, Axis Positioning	± .0002"	.0050mm
Accuracy, Axis Repeatability	± .0001"	.0025mm
Glass Scales (X/Y/Z)	Optional	
Spindle Speed	10-10,000 rpm (15,000 Opt.)	
Spindle Orientation	Electromechanical	
Spindle Taper	No. 40	
ATC, Number of Tools	21 (30 Opt.)	
ATC, Tool Selection	Random, Bi-directional	
Max. Tool Diameter	3" (6" w/o adjacent tools)	76mm (114mm w/o adjacent tools)
Max. Tool Length	15"	381mm
Max. Tool Weight	15 lbs.	6.8 kg
Machine Width and Depth	116" W x 87" D	3m W x 2.21m D
Machine Maximum Height	104"	2.6m
Machine Weight	10,500 lbs.	4763 kg
Air Pressure Reqs. (Momentary)	120 psi, 15 scfm	5.5 Bar
Power Reqs. (3-phase)	40/45 amps, 230 VAC (20/25 480 VAC)	
Single Phase (Optional)	60 amps, 230 VAC	
Cool Power System	Spindle, Headstock, Ballscrews	
Ball Screw Supports (X/Y/Z)	dual	
No. of Ground Boxways per Axis (X/Y/Z)	2	

* Rated Peak Value

VMC 4020A

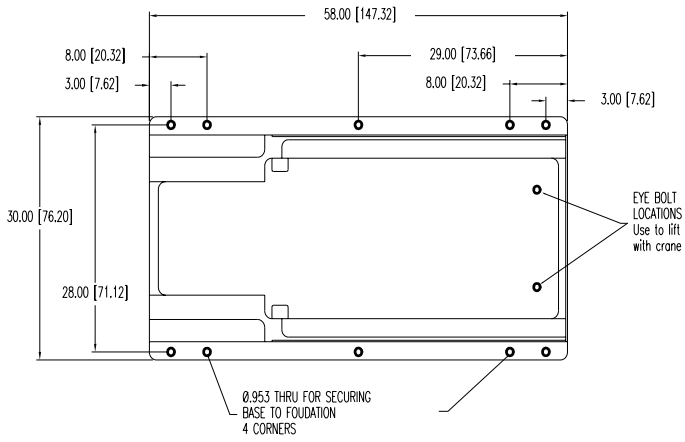
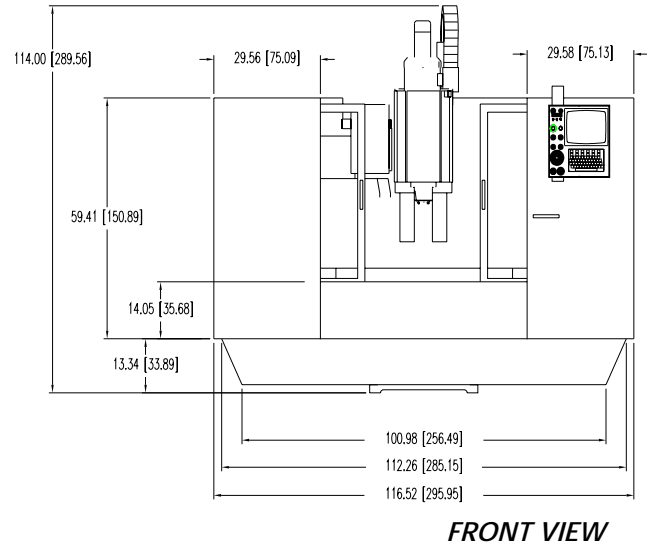
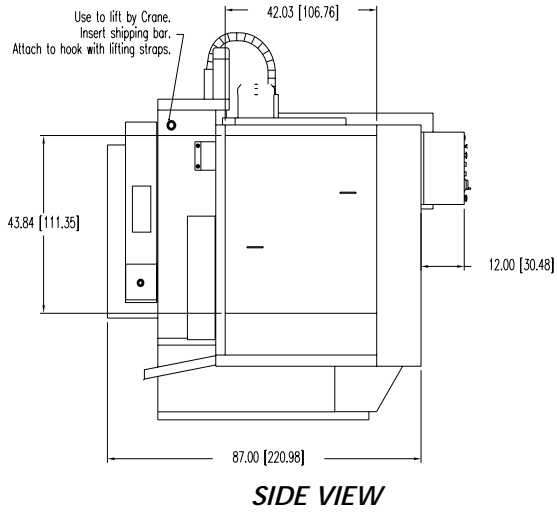

**TOP VIEW
BASE
SCALE 2:1**

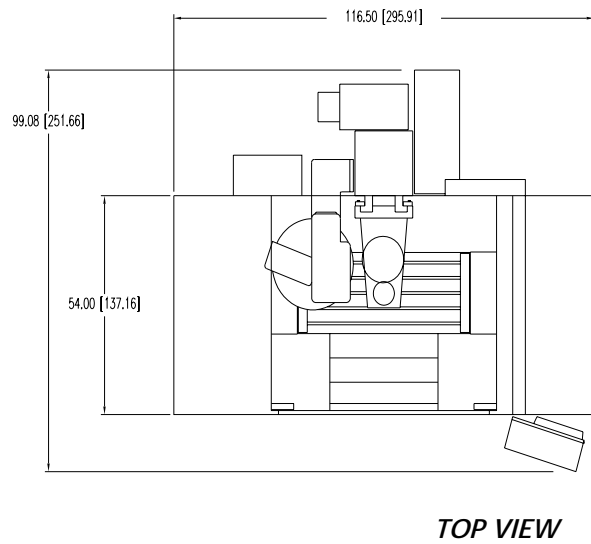

Figure 1-9 VMC 4020A

Note: Dimensions represented in inches & [centimeters]

Table 7: VMC 4020A Specifications

4020A Specifications	4020A Standard	4020A Metric
Table Size	48" x 20"	1,219mm x 508mm
Floor to Table	35"	889mm
T-Slots (No. x Width x Span)	5 x .687" x 3.75"	5 x 17.45mm x 95.25mm
Cutting Feed Rate	.01-400 ipm (600 ipm @ 150%)	.25-10,160 (15,240 at 150%)mm/min.
Rapid Feed Rate (X/Y/Z)	900 ipm (X/Y) 700 ipm (Z)	30.5(X,Y) 17.8(Z) m/min.
Max. Weight on Table	3,000 lbs.	1,361 kg.
Axis Drive Motor (X/Y/Z)	AC, 3, 800 lbs peak thrust	AC, 16,900 N* thrust
Ball Screw Size	40mm Dia. (X/Y/Z)	
Longitudinal (X Axis)	40"	1016mm
Cross (Y Axis)	20"	508mm
Vertical (Z Axis)	20" (28" Opt.)	508mm (711mm Opt.)
Spindle Nose to Table	4"-24" (4"-32" Opt.)	102mm-610mm (102mm-813mm)
Spindle Center to Column Ways	20"	406mm
Main Motor - Automatic 2 Speed Vector	22.5 HP*, 16.8 KW	
Opt. HT Motor - Automatic 2 Speed Vector	N/A	
Torque	120 ft-lbs	220 Nm/300Nm/378Nm
Accuracy, Axis Positioning	± .0002"	.0050mm
Accuracy, Axis Repeatability	± .0001"	.0025mm
Glass Scales (X/Y/Z)	N/A	
Spindle Speed	10-7,500 rpm	
Spindle Orientation	Electromechanical	
Spindle Taper	No. 40	
ATC, Number of Tools	21 (30 Opt.)	
ATC, Tool Selection	Random, Bi-directional	
Max. Tool Diameter	3" (4.5" w/o adjacent tools)	76mm (114mm w/o adjacent tools)
Max. Tool Length	15"	381mm
Max. Tool Weight	15 lbs.	6.8 kg
Machine Width and Depth	116" W x 87" D	3m W x 2.21m D
Machine Maximum Height	104"	2.6m
Machine Weight	11,000 lbs.	4990 kg
Air Pressure Reqs. (Momentary)	120 psi, 15 scfm	5.5 Bar
Power Reqs. (3-phase)	40/45 amps, 230 VAC (20/25 480 VAC)	
Single Phase (Optional)	60 amps, 230 VAC	
Cool Power System	Spindle, Headstock, Ballscrews	
Ball Screw Supports (X/Y/Z)	dual	
No. of Ground Boxways per Axis (X/Y/Z)	2 (Z)	

* Rated Peak Value

VMC 5020A

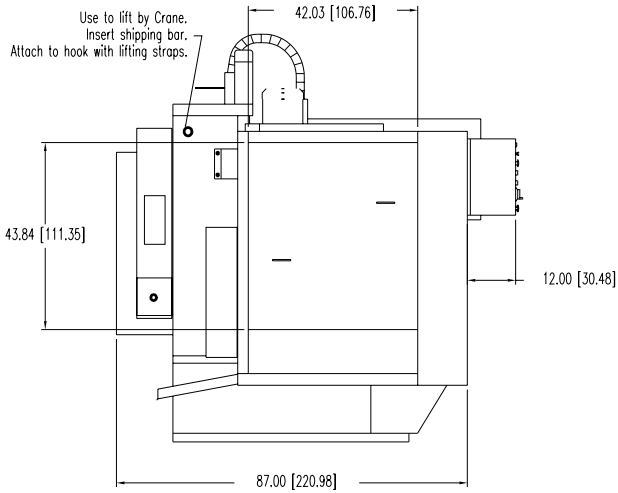

SIDE VIEW

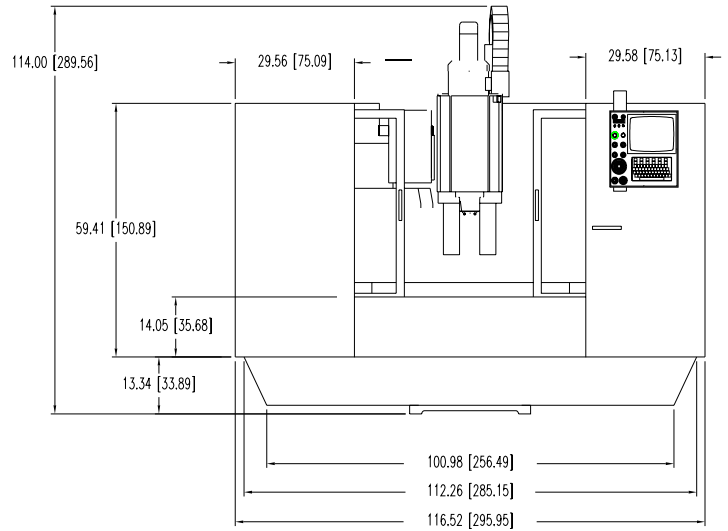

FRONT VIEW

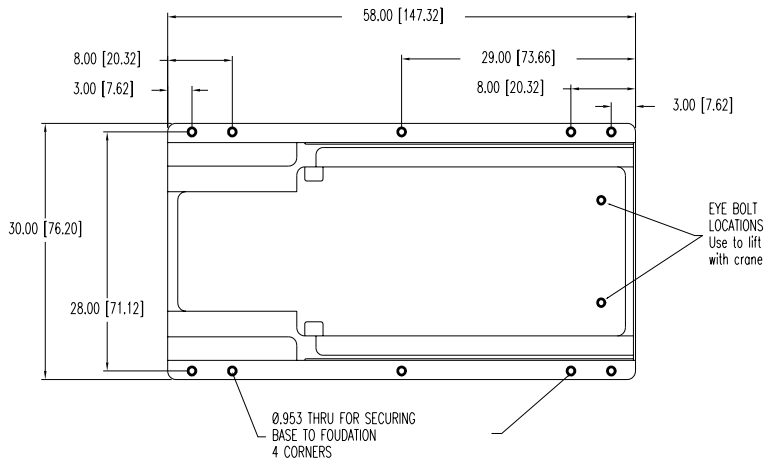

**TOP VIEW
BASE
SCALE 2:1**

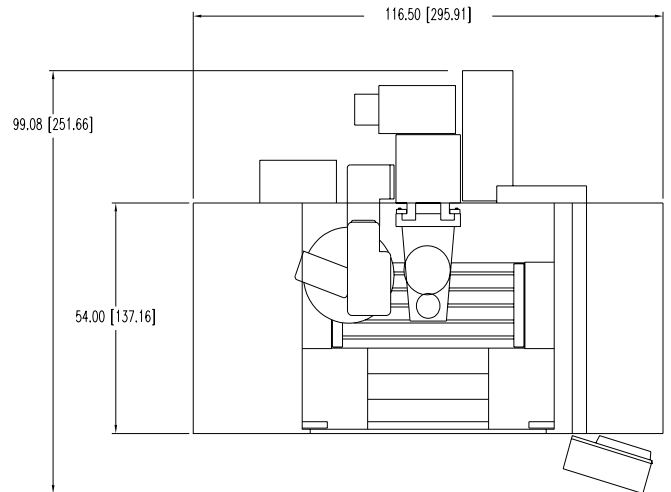

TOP VIEW

Figure 1-10 VMC 5020A

Note: Dimensions represented in inches & [centimeters]

Table 8: VMC 5020A Specifications

5020A Specifications	5020A Standard	5020A Metric
Table Size	58" x 20"	1,473mm x 508mm
Floor to Table	31"	787mm
T-Slots (No. x Width x Span)	3 x .687" x 3.75"	3 x 17.45mm x 95.25mm
Cutting Feed Rate	.01-400 ipm (600 @ 150%)	.25-10,160 (15,240 at 150%)mm/min.
Rapid Feed Rate (X/Y/Z)	900 ipm (X/Y) 700 ipm (Z)	22.8 m/min (X,Y,Z)
Max. Weight on Table	3,000 lbs.	1,361 kg.
Axis Drive Motor (X/Y/Z)	AC, 3,800 lbs peak thrust	AC, 16,900 N* thrust
Ball Screw Size	40mm Dia. (X/Y/Z)	
Longitudinal (X Axis)	50"	1,270 mm
Cross (Y Axis)	20"	508mm
Vertical (Z Axis)	20" (28" Opt.)	508mm (711mm Opt.)
Spindle Nose to Table	4"-24" (4"-32" Opt.)	102mm-610mm (102mm-813mm)
Spindle Center to Column Ways	20"	406mm
Main Motor - Automatic 2 Speed Vector	22.5 HP*, 16.8 KW	
Opt. HT Motor - Automatic 2 Speed Vector	N/A	
Torque	120 ft-lbs	220 Nm/300Nm/378Nm
Accuracy, Axis Positioning	± .0002"	.0050mm
Accuracy, Axis Repeatability	± .0001"	.0025mm
Glass Scales (X/Y/Z)	N/A	
Spindle Speed	10-7,500 rpm	
Spindle Orientation	Electromechanical	
Spindle Taper	No. 40	
ATC, Number of Tools	21 (30 Opt.)	
ATC, Tool Selection	Random, Bi-directional	
Max. Tool Diameter	3" (4.5" w/o adjacent tools)	76mm (114mm w/o adjacent tools)
Max. Tool Length	15"	381mm
Max. Tool Weight	15 lbs.	6.8 kg
Machine Width and Depth	116" W x 87" D	3m W x 2.21m D
Machine Maximum Height	103"	2.6m
Machine Weight	11,500 lbs.	4990 kg
Air Pressure Reqs. (Momentary)	120 psi, 15 scfm	5.5 Bar
Power Reqs. (3-phase)	40/45 amps, 230 VAC (20/25, 480 VAC)	
Single Phase (Optional)	60 amps, 230 VAC	
Cool Power System	Spindle, Headstock, Ballscrews	
Ball Screw Supports (X/Y/Z)	dual	
No. of Ground Boxways per Axis (X/Y/Z)	2 (Z)	

* Rated Peak Value

VMC 6030

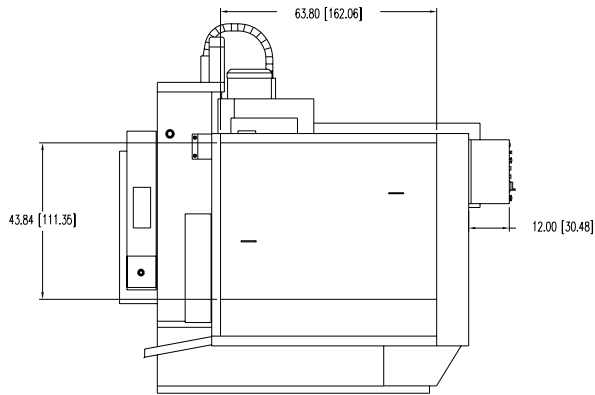

SIDE VIEW

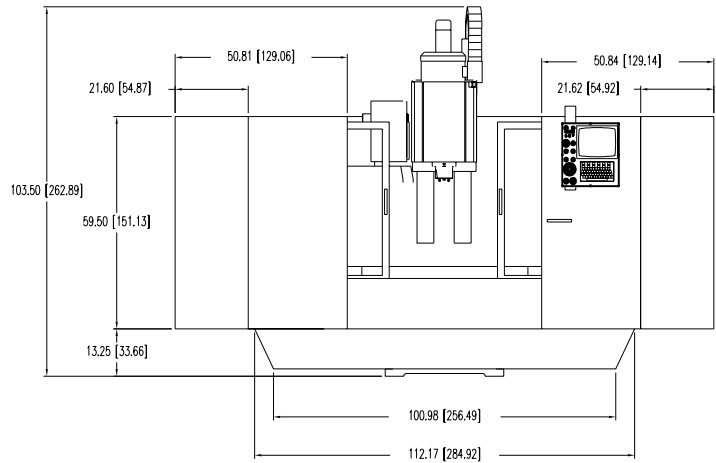

FRONT VIEW

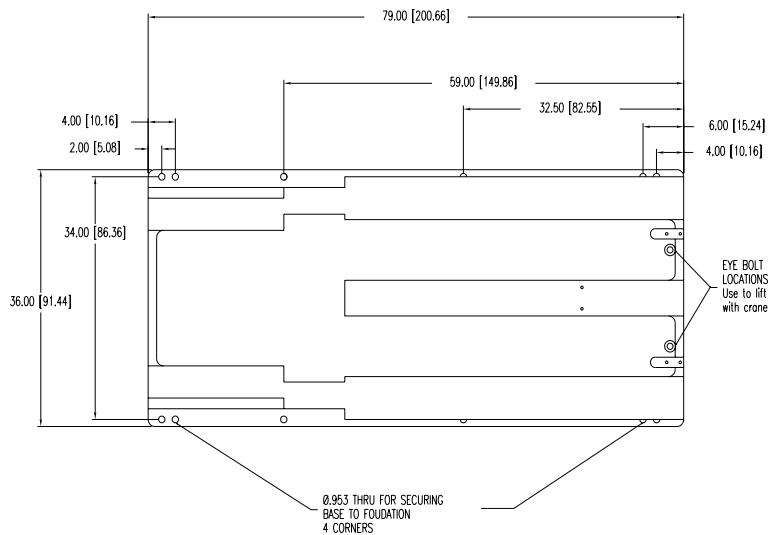

**TOP VIEW
BASE
SCALE 2:1**

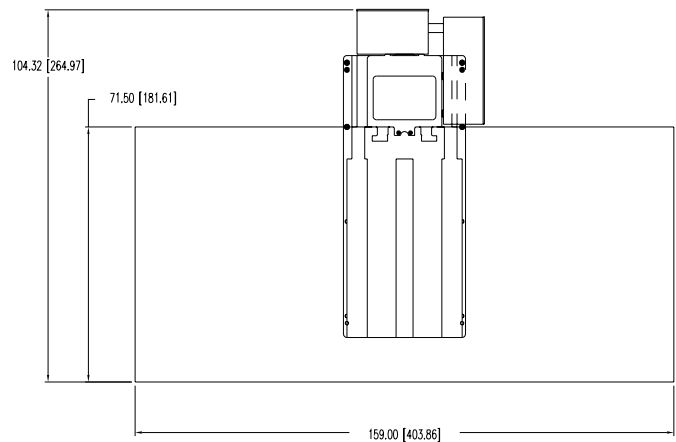

TOP VIEW

Figure 1-11 VMC 6030

Note: Dimensions represented in inches & [centimeters]

Optional Very High Torque Motor 30 Peak Horsepower, 32 Amps continuous current in WYE mode, 56 Amps continuous current in DELTA mode, Peak current may run as high as 70 Amps.

Table 9: VMC 6030 Specifications

6030 Specifications	6030 Standard	6030 Metric
Table Size	62.5 x 30"	1,588mm x 762mm
Floor to Table	36"	914mm
T-Slots (No. x Width x Span)	5 x .687" x 5.5"	5 x 17.5mm x 139.7mm
Cutting Feed Rate	.01-250 ipm (375 @ 150%)	.25-6,350 (9,525 at 150%)mm/min.
Rapid Feed Rate (X/Y/Z)	400 ipm (X/Y/Z)	10.1 m/min (X,Y,Z)
Max. Weight on Table	4,120 lbs.	1,869 kg.
Axis Drive Motor (X/Y/Z)	AC, 5,000 lbs peak thrust	AC, 22,420 N* thrust
Ball Screw Size	1.75" Dia. (X/Y) 1.50" Dia. (Z)	44.45mm Dia (X,Y) 38.1mm Dia. (Z)
Longitudinal (X Axis)	60"	1,524 mm
Cross (Y Axis)	30"	762mm
Vertical (Z Axis)	30"	762mm
Spindle Nose to Table	5.5"-35.5"	140mm-902mm
Spindle Center to Column Ways	16"	406mm
Main Motor - Automatic 2 Speed Vector	15 HP*, 11.2 KW	
Opt. HT Motor - Automatic 2 Speed Vector	22.5 HP*, 16.8 KW	
Torque	160 ft-lbs, 220 ft-lbs (Opt.)	300 Nm/375Nm
Accuracy, Axis Positioning	± .0004"	.0076mm
Accuracy, Axis Repeatability	± .0002"	.0038mm
Glass Scales (X/Y/Z)	Optional	
Spindle Speed	10-10,000 rpm	
Spindle Orientation	Electromechanical	
Spindle Taper	No. 40	
ATC, Number of Tools	21 (30 Opt.)	
ATC, Tool Selection	Random, Bi-directional	
Max. Tool Diameter	3" (4.5" w/o adjacent tools)	76mm (114mm w/o adjacent tools)
Max. Tool Length	15"	381mm
Max. Tool Weight	15 lbs.	6.8 kg
Machine Width and Depth	158" W x 103" D	4m W x 2.6m D
Machine Maximum Height	122"	3.1m
Machine Weight	17,000 lbs.	7,711 kg
Air Pressure Reqs. (Momentary)	120 psi, 15 scfm	5.5 Bar
Power Reqs. (3-phase)	40/45, 230 VAC (20/25, 480 VAC)	
Single Phase (Optional)	60 amps, 230 VAC	
Cool Power System	Spindle, Headstock, Ballscrew (Y)	
Ball Screw Supports (X/Y/Z)	dual	
No. of Ground Boxways per Axis (X/Y/Z)	2	

* Rated Peak Value

VMC 8030

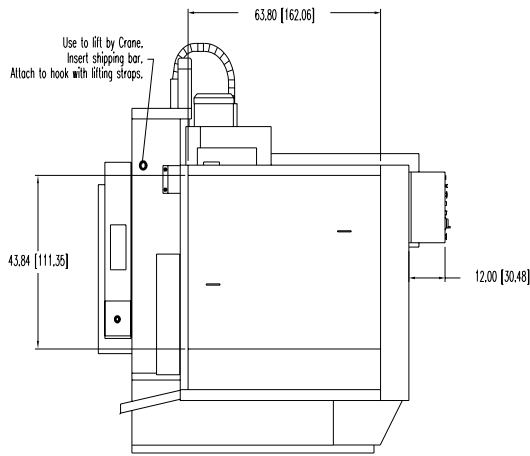

SIDE VIEW

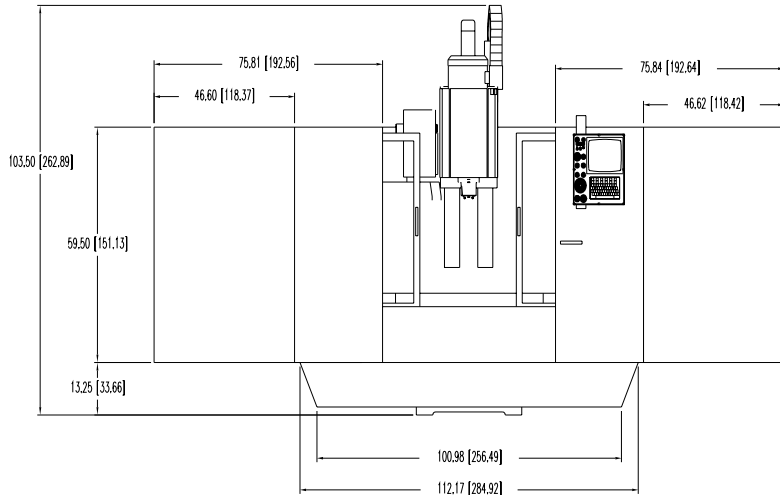

FRONT VIEW

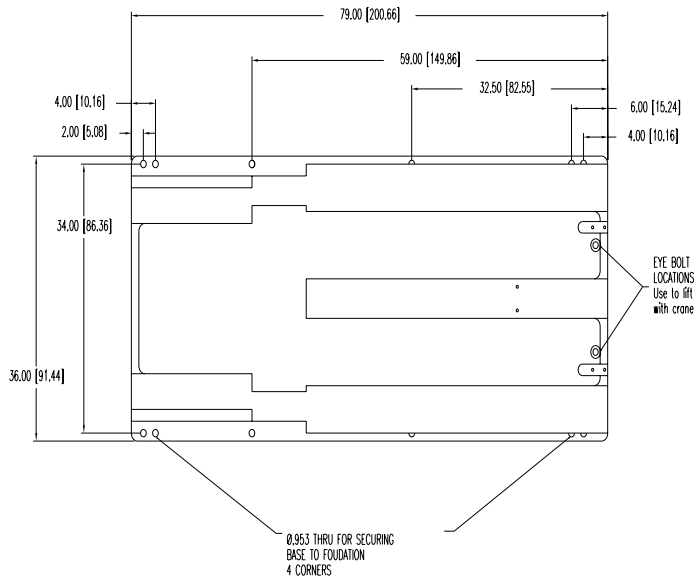

**TOP VIEW BASE
SCALE 2:1**

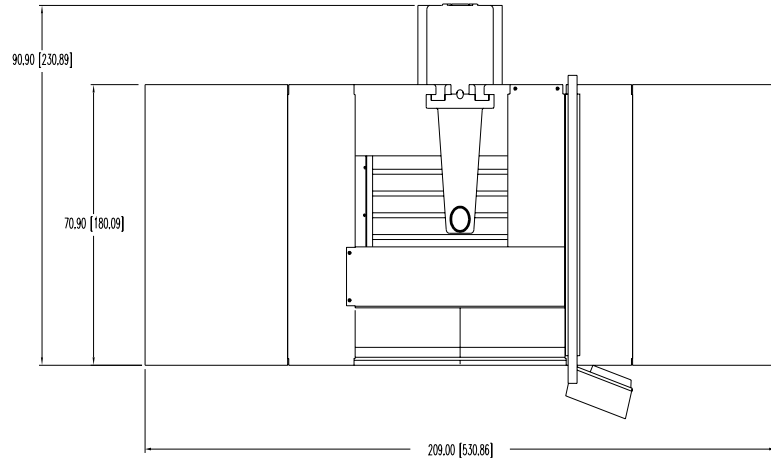

TOP VIEW

Figure 1-12 VMC 8030

Note: Dimensions represented in inches & [centimeters]

Optional Very High Torque Motor 30 Peak Horsepower, 32 Amps continuous current in WYE mode, 56 Amps continuous current in DELTA mode, Peak current may run as high as 70 Amps.

Table 10: VMC 8030 Specifications

8030 Specifications	8030 Standard	8030 Metric
Table Size	82.5" x 30"	2,096mm x 762mm
Floor to Table	36"	914mm
T-Slots (No. x Width x Span)	5 x .687" x 5.5"	5 x 17.5mm x 139.7mm
Cutting Feed Rate	.01-250 ipm (3765 @ 150%)	.25-6,350 (9,525 at 150%)mm/min.
Rapid Feed Rate (X/Y/Z)	400 ipm (X/Y/Z)	10.1 m/min (X,Y,Z)
Max. Weight on Table	3,751 lbs.	1,701 kg.
Axis Drive Motor (X/Y/Z)	AC, 5,000 lbs peak thrust	AC, 22,420 N* thrust
Ball Screw Size	1.75" Dia. (X/Y) 1.50" Dia. (Z)	44.45mm Dia (X,Y) 38.1mm Dia. (Z)
Longitudinal (X Axis)	80"	2,032 mm
Cross (Y Axis)	30"	762mm
Vertical (Z Axis)	30"	762mm
Spindle Nose to Table	5.5"-35.5"	140mm-902mm
Spindle Center to Column Ways	16"	406mm
Main Motor - Automatic 2 Speed Vector	15 HP*, 11.2 KW	
Opt. HT Motor - Automatic 2 Speed Vector	22.5 HP*, 16.8 KW	
Torque	160 ft-lbs, 220 ft-lbs (Opt.)	300 Nm/375Nm
Accuracy, Axis Positioning	± .0004"	.0076mm
Accuracy, Axis Repeatability	± .0002"	.0038mm
Glass Scales (X/Y/Z)	Optional	
Spindle Speed	10-10,000 rpm (15,000 Opt.)	
Spindle Orientation	Electromechanical	
Spindle Taper	No. 40	
ATC, Number of Tools	21 (30 Opt.)	
ATC, Tool Selection	Random, Bi-directional	
Max. Tool Diameter	6"	152mm
Max. Tool Length	15"	381
Max. Tool Weight	15 lbs.	6.8 kg
Machine Width and Depth	209" W x 103" D	5.3m W x 2.6m D
Machine Maximum Height	119"	3m
Machine Weight	18,000 lbs.	8,165 kg
Air Pressure Reqs. (Momentary)	120 psi, 15 scfm	5.5 Bar
Power Reqs. (3-phase)	45 amps, 230 VAC (20/25 amps, 480 VAC)	
Single Phase (Optional)	60 amps, 230 VAC	
Cool Power System	Spindle, Headstock, Ballscrew (Y)	
Ball Screw Supports (X/Y/Z)	dual	
No. of Ground Boxways per Axis (X/Y/Z)	2	

* Rated Peak Value

VMC 3020

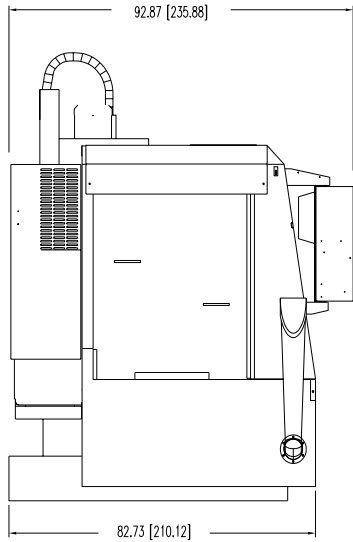

SIDE VIEW

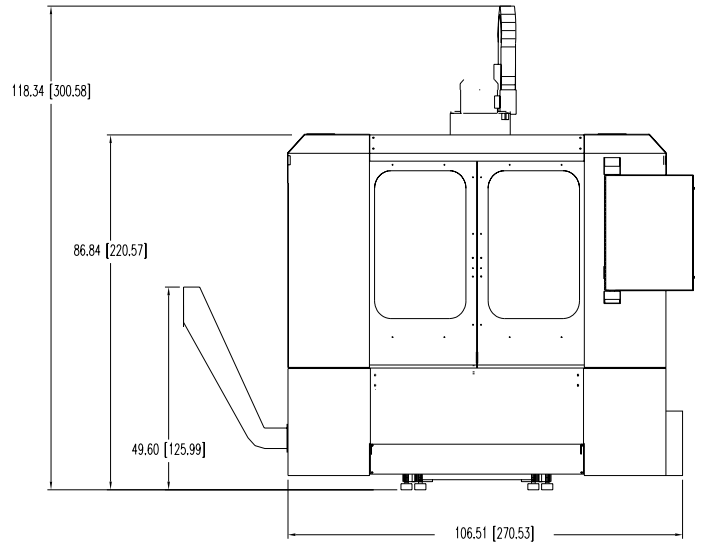

FRONT VIEW

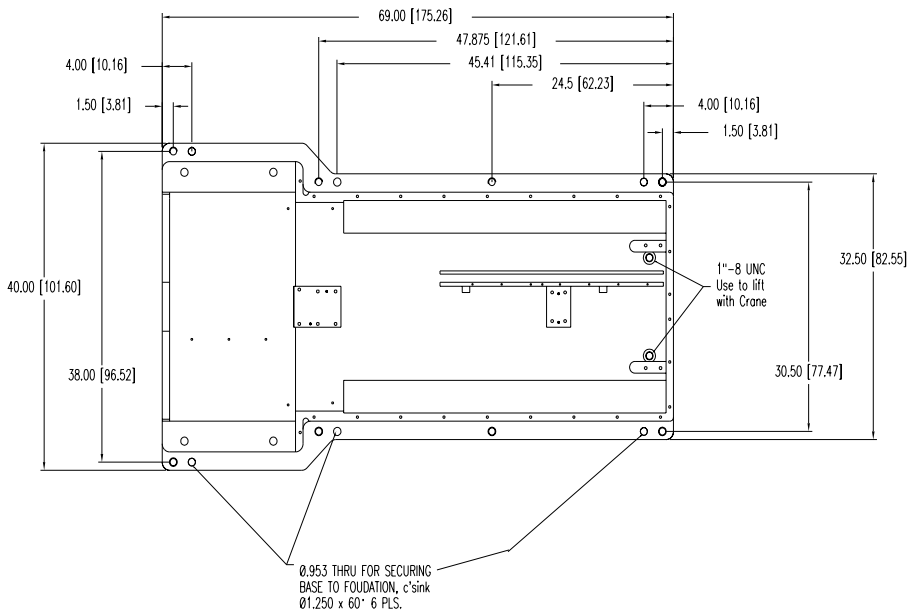

**TOP VIEW
BASE
SCALE 2:1**

Use to lift with crane. Wrap sling around counterweight shipping bars.

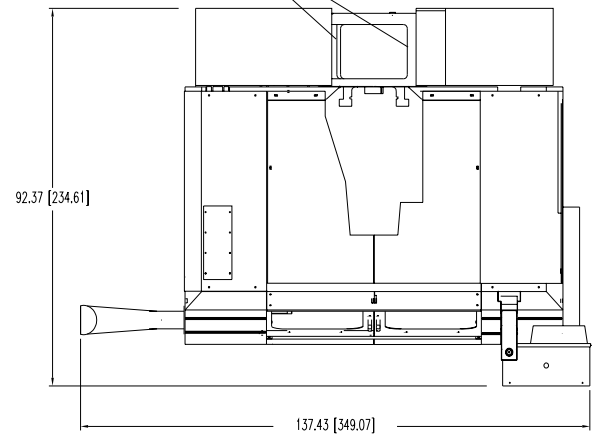

TOP VIEW

Figure 1-13 VMC 3020

Note: Dimensions represented in inches & [centimeters]

Optional Very High Torque Motor 30 Peak Horsepower, 32 Amps continuous current in WYE mode, 56 Amps continuous current in DELTA mode, Peak current may run as high as 70 Amps.

Table 11: VMC 3020 Specifications

3020 Specifications	3020 Standard	3020 Metric
Table Size	40.5" x 20"	1,029mm x 508mm
Floor to Table	31"	787mm
T-Slots (No. x Width x Span)	5 x .709" x 3.75"	5 x 18mm x 95.3mm
Cutting Feed Rate	.01-400 ipm (600 ipm @ 150%)	.25-10,160 (15,240 at 150%)
Rapid Feed Rate (X/Y/Z)	900 ipm (X/Y) 700 ipm (Z)	30.5(X,Y) 17.8(Z) m/min
Max. Weight on Table	4,250 lbs.	1,928 kg.
Axis Drive Motor (X/Y/Z)	AC 3,800 lbs peak thrust	AC, 16,903 N*thrust.
Ball Screw Size	40mm Dia. (X/Y/Z)	
Longitudinal (X Axis)	30"	762 mm
Cross (Y Axis)	20"	508mm
Vertical (Z Axis)	20" (24" Opt.)	508mm (610mm)
Spindle Nose to Table	4"-24" (28" Opt.)	102mm-610mm-(711mm Opt.)
Spindle Center to Column Ways	22.875"	581mm
Main Motor - Automatic 2 Speed Vector	15 HP*, 11.2 KW	
Opt. HT Motor - Automatic 2 Speed Vector	22.5 HP*, 16.8 KW	
Torque	160 ft-lbs, 290 ft-lbs (Opt.)	300 Nm/375Nm
Accuracy, Axis Positioning	± .0002"	±.004mm
Accuracy, Axis Repeatability	± .0001"	±.0015mm
Glass Scales (X/Y/Z)	Optional	
Spindle Speed	10-10,000 rpm (15,000 Opt.)	
Spindle Orientation	Electromechanical	
Spindle Taper	No. 40	
ATC, Number of Tools	21 (30 Opt.)	
ATC, Tool Selection	Random, Bi-directional	
Max. Tool Diameter	3" (4.5" w/o adjacent tools)	76.2mm (114.3mm)
Max. Tool Length	15"	381mm
Max. Tool Weight	15 lbs.	6.8 kg
Machine Width and Depth	106" W x 85" D	2.7m W x 2.16m D
Machine Maximum Height	96" (102" with 22.5 HP Opt.)	2.4m (2.6m with 22.5hp. Opt)
Machine Weight	12,400 lbs.	5,625 kg
Air Pressure Reqs. (Momentary)	120 psi, 15 scfm	5.5 Bar
Power Reqs. (3-phase)	45 amps, 230 VAC (20/25 amps, 480 VAC)	
Single Phase (Optional)	60 amps, 230 VAC	
Cool Power System	Spindle, Headstock, Ballscrews	
Ball Screw Supports (X/Y/Z)	dual	
No. of Ground Boxways per Axis (X/Y/Z)	2	

* Rated Peak Value

VMC 4525

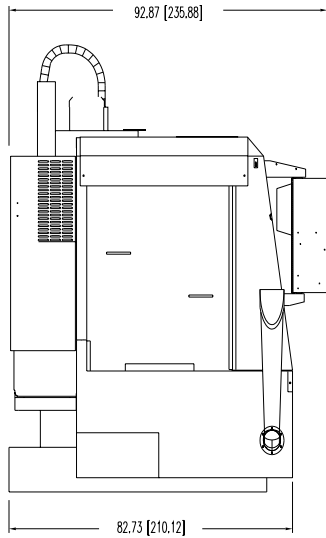

SIDE VIEW

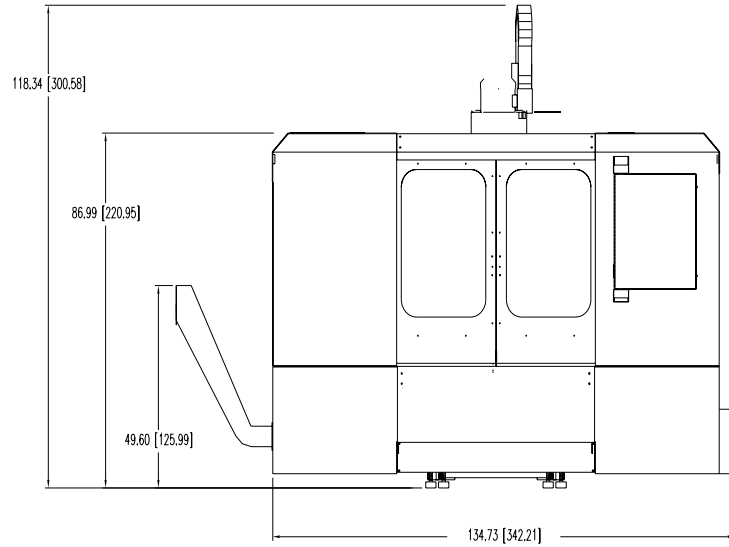

FRONT VIEW

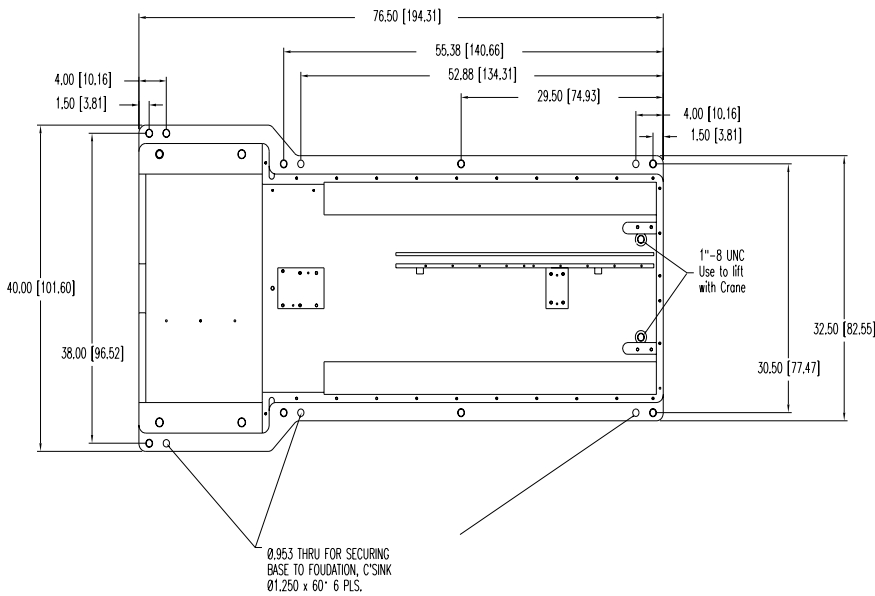

**TOP VIEW
BASE
SCALE 2:1**

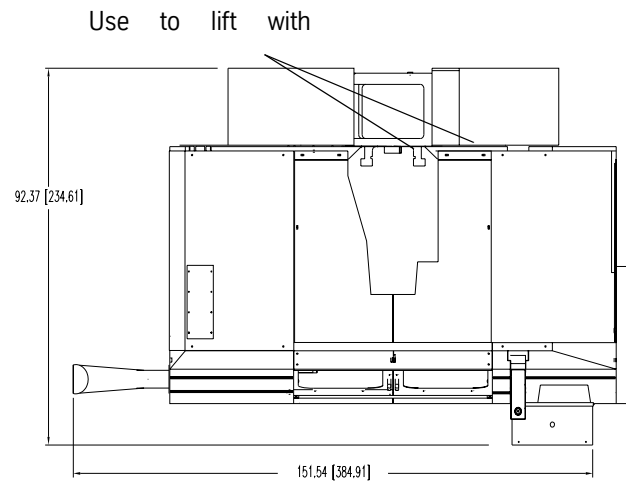

Figure 1-14 VMC 4525

Note: Dimensions represented in inches & [centimeters]

Table 12: VMC 4525 Specifications

4525 Specifications	4525 Standard	4525 Metric
Table Size	53.5" x 25"	1,359mm x 635mm
Floor to Table	31"	787mm
T-Slots (No. x Width x Span)	5 x .709" x 4.92"	5 x 18mm x 125mm
Cutting Feed Rate	.01-400 ipm (600 ipm @ 150%)	.25-10,160 (15,240 at 150%)
Rapid Feed Rate (X/Y/Z)	900 ipm (X/Y) 700 ipm (Z)	30.5(X,Y) 17.8(Z) m/min
Max. Weight on Table	4,250 lbs.	1,928 kg.
Axis Drive Motor (X/Y/Z)	AC 3,800 lbs peak thrust	AC, 16,903 N*thrust.
Ball Screw Size	40mm Dia. (X/Y/Z)	
Longitudinal (X Axis)	45"	1,143 mm
Cross (Y Axis)	25"	635mm
Vertical (Z Axis)	24"	610
Spindle Nose to Table	4"-24"	102mm-610mm
Spindle Center to Column Ways	27.87"	708mm
Main Motor - Automatic 2 Speed Vector	22.5 HP*, 16.8 KW	
Opt. HT Motor - Automatic 2 Speed Vector	30 HP*, 22.4 KW	
Torque	220 ft-lbs, 270 ft-lbs (Opt.)	300 Nm/375Nm
Accuracy, Axis Positioning	± .00016"	±.004mm
Accuracy, Axis Repeatability	± .00006"	±.0015mm
Glass Scales (X/Y/Z)	Optional	
Spindle Speed	10-10,000 rpm (15,000 Opt.)	
Spindle Orientation	Electromechanical	
Spindle Taper	No. 40	
ATC, Number of Tools	1.9 sec dual arm / 24 tools	
ATC, Tool Selection	Random, Bi-directional	
Max. Tool Diameter	4" (4.5" w/o adjacent tools)	101.6mm (114.3mm)
Max. Tool Length	15"	381mm
Max. Tool Weight	15 lbs.	6.8 kg
Machine Width and Depth	128" W x90" D	3.25m W x 2.3m D
Machine Maximum Height	120"	3m
Machine Weight	13,600 lbs.	6,169 kg
Air Pressure Reqs. (Momentary)	120 psi, 15 scfm	5.5 Bar
Power Reqs. (3-phase)	40/60 amps, 230 VAC (20/25 amps, 480 VAC)	
Single Phase (Optional)	60 amps, 230 VAC	
Cool Power System	Spindle, Headstock, Ballscrews	
Ball Screw Supports (X/Y/Z)	dual	
No. of Ground Boxways per Axis (X/Y/Z)	2	

* Rated Peak Value

VMC 6535

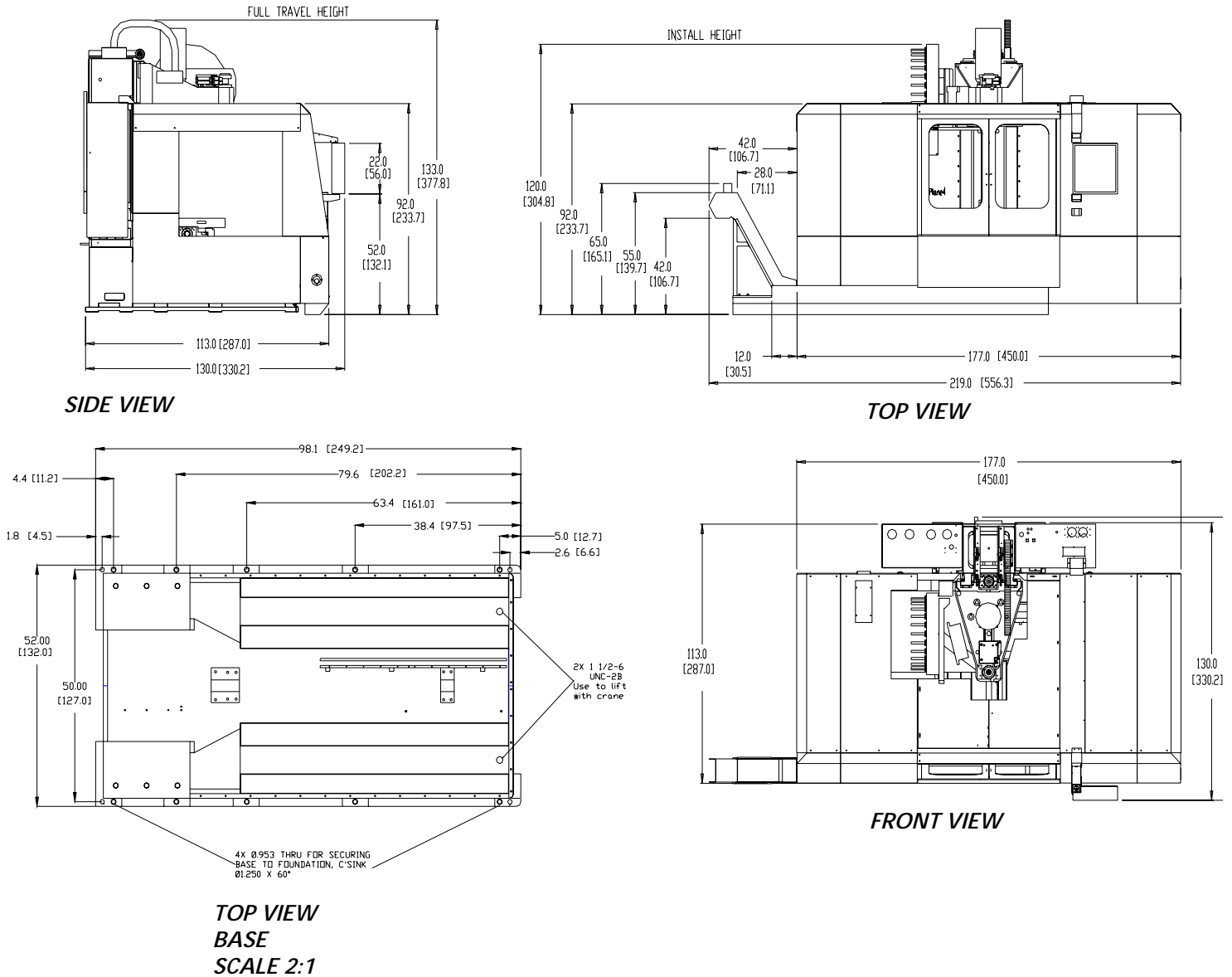

Figure 1-15 VMC 6535

Note: Dimensions represented in inches & [centimeters]

Table 13: VMC 6535 Specifications

6535 Specifications	6535 Standard	6535 Metric
Table Size	74.8" x 26.5"	1,899mm x 673.1mm
Floor to Table	40.3"	1024mm
T-Slots (No. x Width x Span)	5 x .709" x 4.92"	5 x 18mm x 125mm
Cutting Feed Rate	.01-400 ipm (600 ipm @ 150%)	.25-10,160 (15,240 at 150%)
Rapid Feed Rate (X/Y/Z)	900 ipm (X/Y) 700 ipm (Z)	30.5(X,Y) 17.8(Z) m/min
Max. Weight on Table	4,250 lbs.	1,928 kg.
Axis Drive Motor (X/Y/Z)	AC 3,800 lbs peak thrust	AC, 16,903 N*thrust.
Ball Screw Size	62.2mm Dia. (X/Y/Z)	
Longitudinal (X Axis)	65"	1,651mm
Cross (Y Axis)	35"	889mm
Vertical (Z Axis)	34"	864mm
Spindle Nose to Table	5"-39"	127mm-991mm
Spindle Center to Column Ways	37.4"	950mm
Main Motor - Automatic 2 Speed Vector	22.5 HP*, 16.8 KW	
Opt. HT Motor - Automatic 2 Speed Vector	30 HP*, 22.4 KW	
Torque	220 ft-lbs, 270 ft-lbs (Opt.)	300 Nm/375Nm
Accuracy, Axis Positioning	± .00016"	±.004mm
Accuracy, Axis Repeatability	± .00006"	±.0015mm
Glass Scales (X/Y/Z)	Optional	
Spindle Speed	10-10,000 rpm (15,000 Opt.),(7,500, 50 tpr.Opt.)	
Spindle Orientation	Electromechanical	
Spindle Taper	No. 40 (50 Opt.)	
ATC, Number of Tools	1.9 sec dual arm / 24 tools (32, 50 tpr. Opt.)	
ATC, Tool Selection	Random, Bi-directional	
Max. Tool Diameter	Ø9.85"	Ø250mm
Max. Tool Length	15.75"	400mm
Max. Tool Weight	40 lbs.	18 kg
Machine Width and Depth	219" W x130" D	5.56m W x 3.3m D
Machine Maximum Height	133"	3.4m
Machine Weight	29,000 lbs.	6,169 kg
Air Pressure Reqs. (Momentary)	120 psi, 15 scfm	5.5 Bar
Power Reqs. (3-phase)	40/60 amps, 230 VAC (20/25 amps, 480 VAC)	
Power Reqs. (3-phase) 50 taper	70 amps, 480 VAC	
Cool Power System	Spindle, Ballscrews	
Ball Screw Supports (X/Y/Z)	dual	
No. of Ground Boxways per Axis (X/Y/Z)	2	

Fadal Bolt Torque Specifications

Table 14: Fadal Bolt Torque Specifications

COLUMN	ALL	COLUMN TO BASE	5/8"-11 X X.50 HHB	175	FT-LBS
COLUMN	ALL	COUPLER SET SCREW	1/4"-20 X 0.50 SHSS	70	IN-LBS
COLUMN	ALL	Z B/S MOUNT IN BACK	3/8"-16 X X.XX HHB	45	FT-LBS
COLUMN	ALL	Z B/S MOUNT IN FRONT	1/2"-13 X 2.XX HHB	75	FT-LBS
COLUMN	ALL	Z B/S NUT	5/16"-18 X 1.25 HHB	30	FT-LBS
COLUMN	ALL	Z MOTOR	3/8"-16 X 1.25 SHCS	40	FT-LBS
COLUMN	ALL	Z XT B/S BEARING MOUNT	5/16"-18 X 1.50 HHB	25	FT-LBS
COLUMN	ALL	Z XT B/S BEARING SUPPORT (60/8030)	3/8"-18 X X.XX HHB	40	FT-LBS
COLUMN	ALL	Z XT B/S SUPPORT ADAPTER	5/16"-18 X 1.50 SHCS	15	FT-LBS
HEAD	ALL	SPINDLE	3/8"-16 X 1.00 SHCS	45	FT-LBS
HEAD	ALL	SPINDLE RETAINING RING	3/8"-16 X 1.00 HHB	25	FT-LBS
HEAD	7.5K RPM	DRAWBAR PISTON	1/4"-20 X 2.00 HHB	15	FT-LBS
HEAD	7.5K RPM	ORIENTATION BRIDGE (7.5K)	3/8"-16 X 6.00 SHCS	45	FT-LBS
HEAD	10K RPM	BACK BELT GUIDE	1/2"-13 X 4.00 HHB	70	FT-LBS
HEAD	10K RPM	HYDRAULIC PISTON	1/4"-20 X 2.00 HHB	15	FT-LBS
HEAD	10K RPM	ORIENTATION BRIDGE (10K)	5/16"-18 X 6.00 HHB	30	FT-LBS
HEAD	10K RPM	SPINDLE MOTOR	1/2"-13 X X.XX HHB	65	FT-LBS
HEAD	10K RPM	SPINDLE MOTOR MOUNT	1/2"-13 X X.XX SHCS	70	FT-LBS
HEAD	10K RPM	VIBRATION MOUNTS	1/2"-13 X 0.75 SHCS	70	FT-LBS
HEAD	10K RPM	Z STRAP	3/8"-16 X 1.75 HHB	45	FT-LBS
X-Y AXIS	ALL	SADDLE STRAP	3/8"-16 X 1.75 HHB	45	FT-LBS
X-Y AXIS	ALL	TABLE STRAP	3/8"-16 X 0.75 HHB	45	FT-LBS
X-Y AXIS	ALL	X B/S NUT	5/16"-18 X 1.XX HHB	25	FT-LBS
X-Y AXIS	ALL	X-Y MOTOR	3/8"-16 X 1.XX SHSC	40	FT-LBS
X-Y AXIS	ALL	Y B/S NUT	5/16"-18 X 1.XX SHCS	30	FT-LBS
X-Y AXIS	A MODEL	LOCATING SET SCREW	#10-32 X .50 SHSS	30	IN-LBS
X-Y AXIS	A MODEL	RAIL GUIDE MOUNT SCREW	1/2"-13 X 1.75 SHCS	70	FT-LBS
X-Y AXIS	A MODEL	TABLE B/S BLOCK MOUNT (4020/A)	3/8"-16 X 3.50 SHCS	40	FT-LBS
X-Y AXIS	A MODEL	X B/S SUPPORT MOUNT (A MODELS)	5/16"-18 X 1.50 SHCS	40	FT-LBS
X-Y AXIS	A MODEL	X-Y MOTOR MOUNT (A MODELS)	3/8"-16 X 1.25 SHCS	40	FT-LBS
X-Y AXIS	60/8030	TABLE B/S BLOCK MOUNT (60/8030)	3/8"-16 X 3.50 SHCS	40	FT-LBS
X-Y AXIS	60/8030	X B/S SUPPORT MOUNT (60/8030)	1/2"-13 X 4.50 HHB	80	FT-LBS
X-Y AXIS	60/8030	X MOTOR MOUNT (60/8030)	1/2"-13 X 3.50 HHB	80	FT-LBS
X-Y AXIS	60/8030	Y MOTOR MOUNT (60/8030)	3/8"-16 X 1.50 HHB	40	FT-LBS
X-Y AXIS	22/30/4020	TABLE B/S BLOCK MOUNT (22/3016)	5/16"-18 X 2.75 SHCS	25	FT-LBS
X-Y AXIS	22/30/4020	X B/S SUPPORT MOUNT (22/30/4020)	3/8"-16 X 1.75 HHB	40	FT-LBS
X-Y AXIS	22/30/4020	X-Y MOTOR MOUNT (22/30/4020)	1/2"-13 X 3.XX HHB	80	FT-LBS
X-Y AXIS	15/L	RAIL GUIDE MOUNT SCREW	5/16"-18 X 1.25 SHSC	25	FT-LBS
X-Y AXIS	15/L	RAIL LOCATING SET SCREW (A/L MODELS)	#10-32 X .50 SHSS	15	IN-LBS
X-Y AXIS	15/L	TABLE B/S BLOCK MOUNT	5/16"-18 X 2.00 SHCS	25	FT-LBS
X-Y AXIS	15/L	X B/S SUPPORT MOUNT	3/8"-16 X 1.75 HHB	40	FT-LBS
X-Y AXIS	15/L	X MOTOR MOUNT (15/L)	5/16"-18 X 2.00 SHSC	25	FT-LBS
X-Y AXIS	15/L	Y MOTOR MOUNT (15/L)	3/8"-16 X 1.75 HHB	40	FT-LBS

Table & T-Slot Dimensions

TRM Table

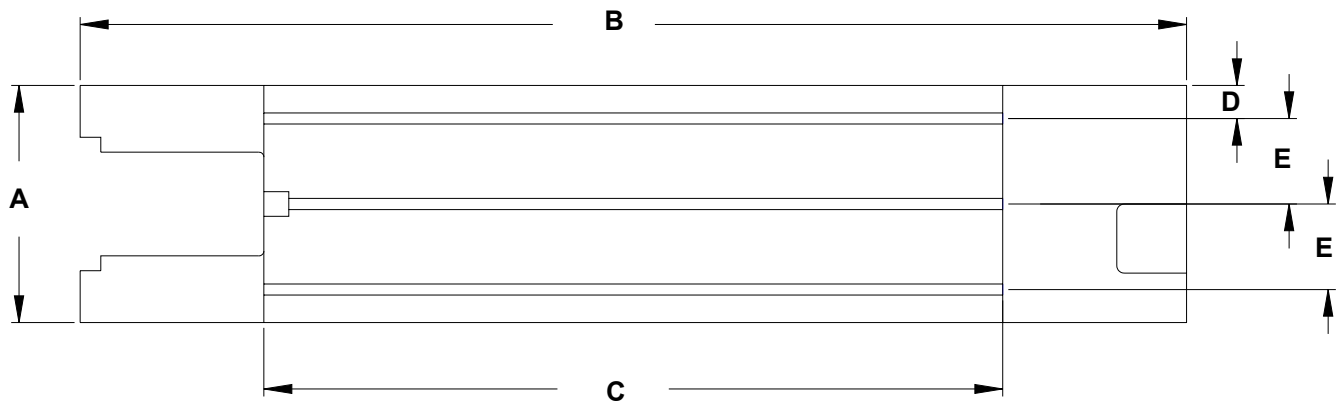

Figure 1-16 TRM Table

A = 12.00" (304.8mm) B = 35.00" (889mm) C = 35.72" (907.29)
D = 1.625" (41.28mm) E = 4.375" (111mm)

EMC, 15 & 2016L
Table

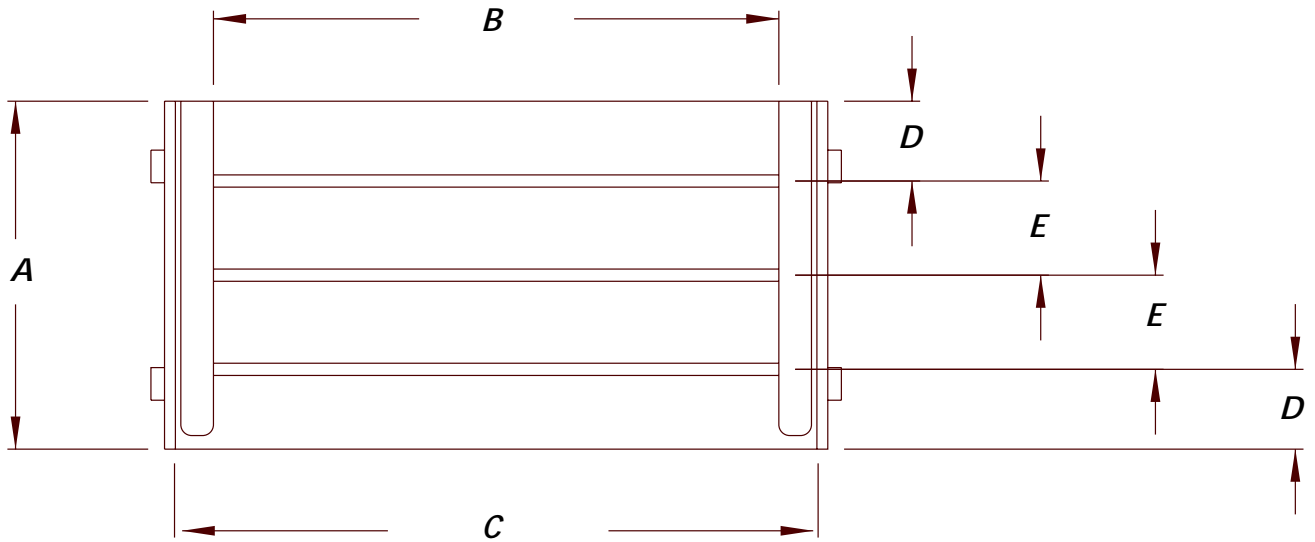

Figure 1-17 EMC, 15 & 2016L Table

A = 16.00" (406.4mm) B = 26.00" (660.4 mm) C = 29.50" (749.3mm)
 D = 3.67" (93.22mm) E = 4.33" (109.98mm)

2216 & 3016 Table

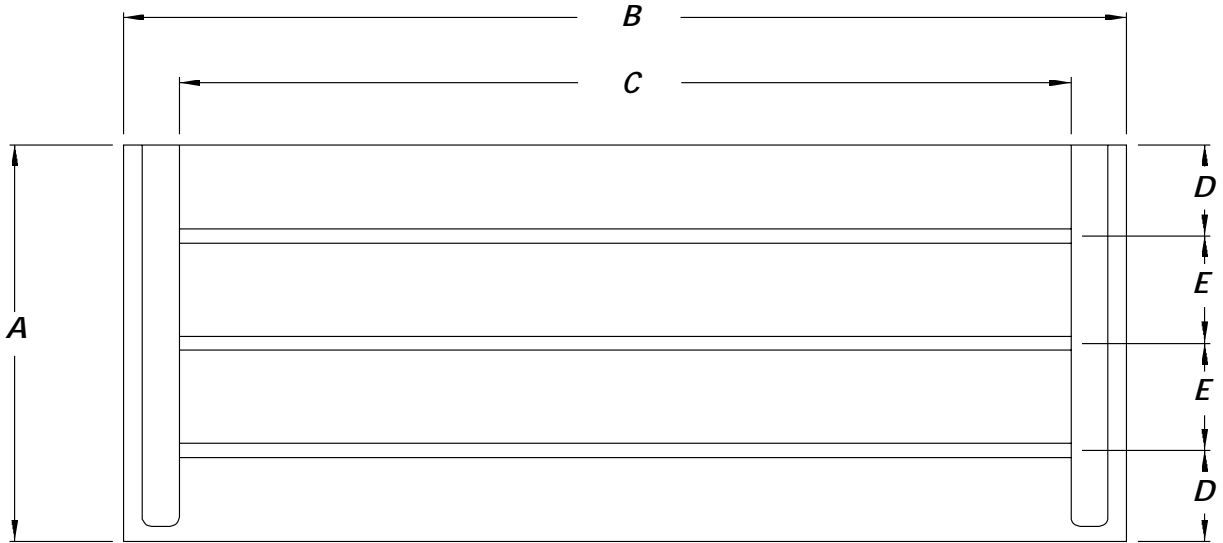

Figure 1-18 2216 & 3016 Table

A = 16.00" (40.64mm) B = 40.50" (1028.7mm) C = 36.00" (914.4mm)
 D = 3.67" (93.22mm) E = 4.33" (109.98mm)

EMC, 15XT & 3016L
Table

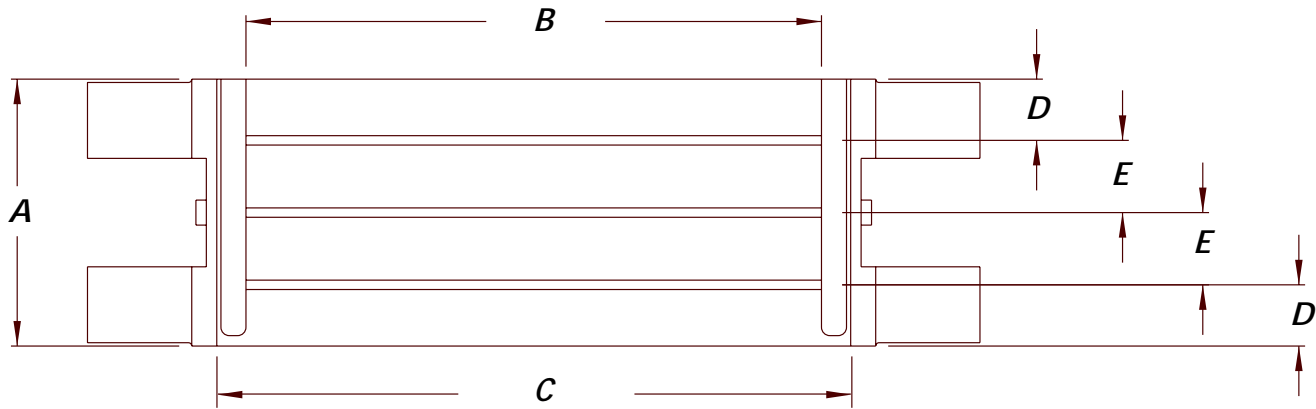

Figure 1-19 EMC, 15XT & 3016L Table

A = 16.00" (406.4mm) B = 34.50" (876.3mm) C = 39.00" (990.6mm)
 D = 3.67" (93.22mm) E = 4.33" (109.98mm)

EMC, 15, 15XT,
2216, 3016, 2016L
& 3016L T-Slots

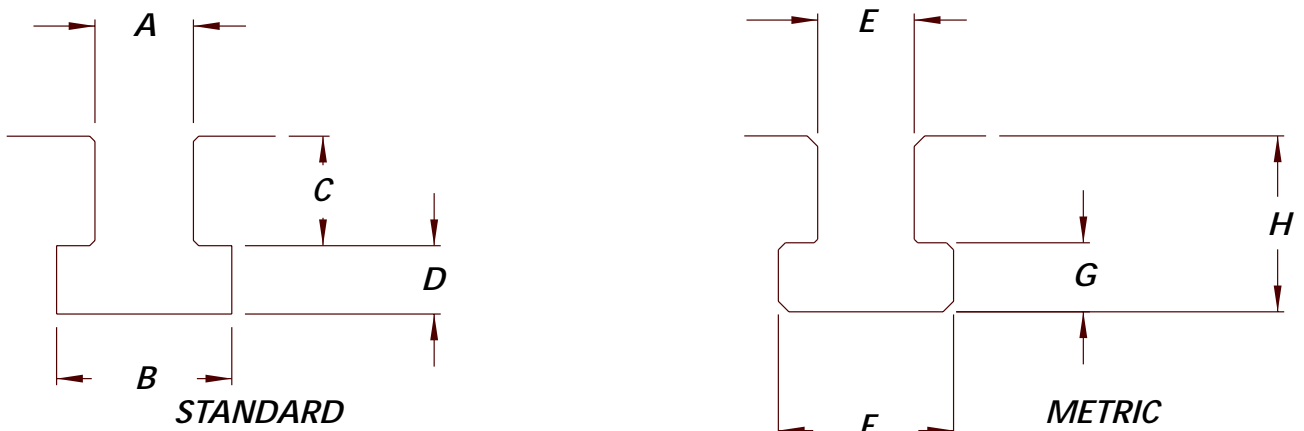

Figure 1-20 EMC, 15, 15XT, 2216, 3016, 2016L & 3016 T-Slots

Standard T-Slot Dimensions:

A = .5625"-.5645" (14.26-14.34mm) B = .970" (24.64mm)
 C = .625" (15.88mm) D = .390" (9.91mm)

Metric T-Slot Dimensions:

E = .5510-.5525" (14-14.03mm) F = .915-.975" (23.29-24.765mm)
 G = .364-.424" (9.25-10.77mm) H = 1.004" (25.5mm)

3020, 4525 Table & T-Slots

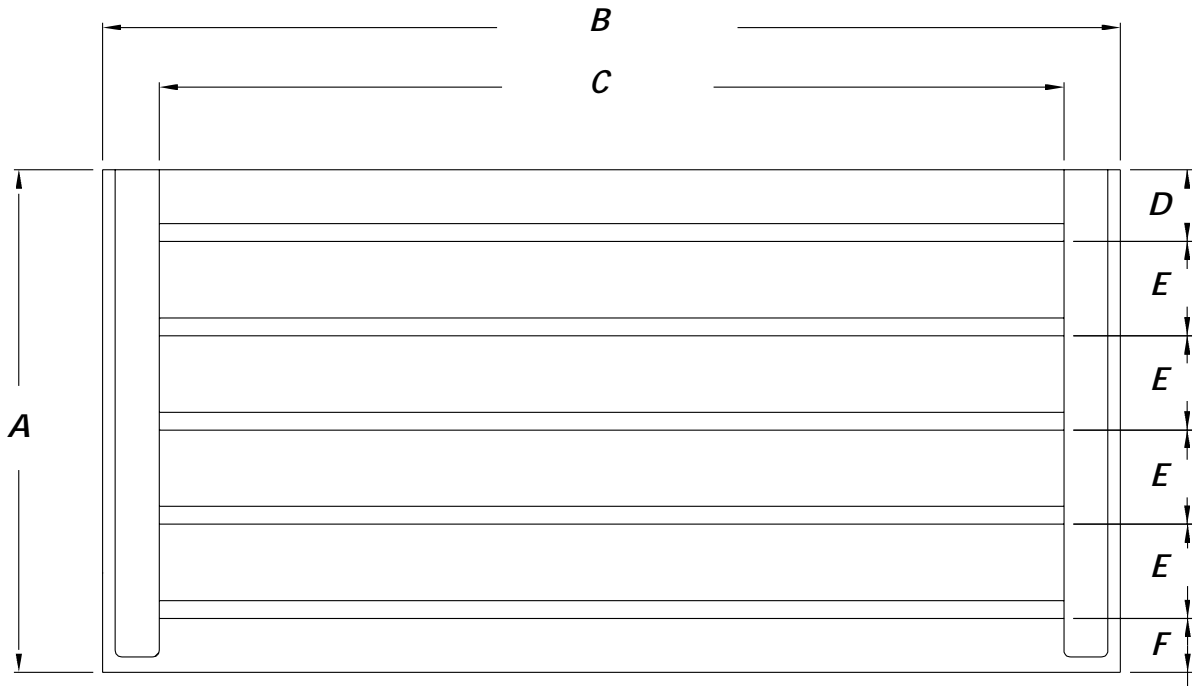

Figure 1-21 3020, 4525 Table & Slots

A = 20.0" (508mm) B = 40.50" (1028.7mm) C = 36.00" (990.6mm)
 D = 2.885" (73.28mm) E = 3.750" (95.25mm) F = 2.145" (54.483mm)

4020 Table

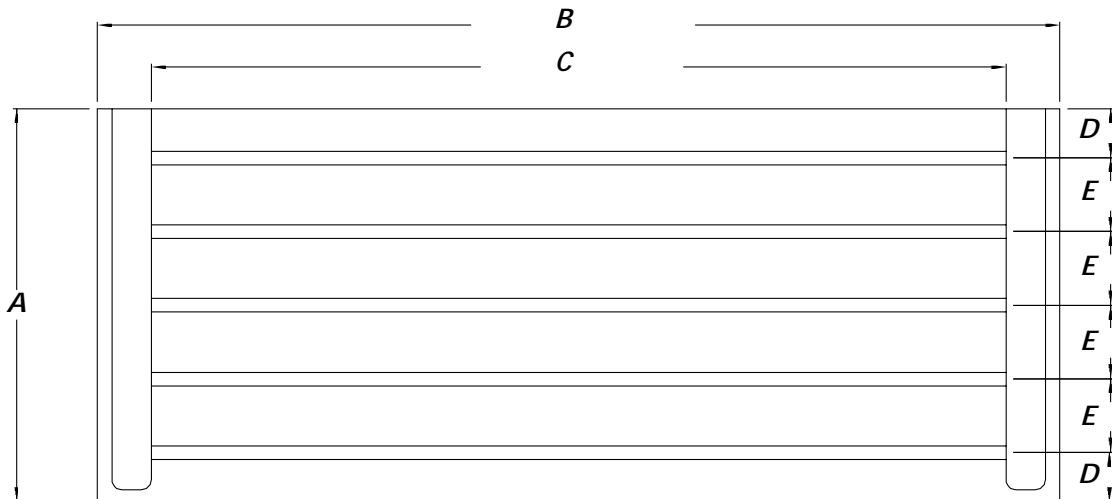

Figure 1-22 4020 Table

A = 20.00" (508mm) B = 49.00" (1244.6mm) C = 43.50" (1104.9mm)
 D = 2.05" (63.5mm) E = 3.75" (95.25mm)

4020A & 5020A
Table

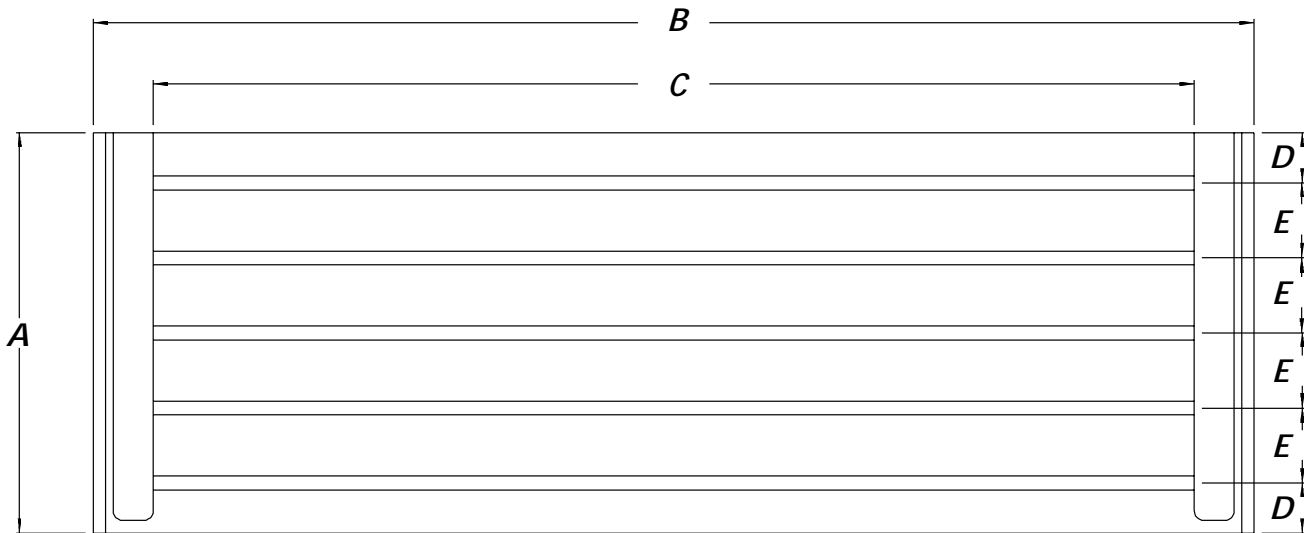

Figure 1-23 4020A & 5020A Table

A = 20.00" (508mm) B = 58.00" (1473.2mm) C = 52.00" (1320.8mm)
 D = 2.50" (73.28mm) E = 3.75" (95.25mm)

6030 Table

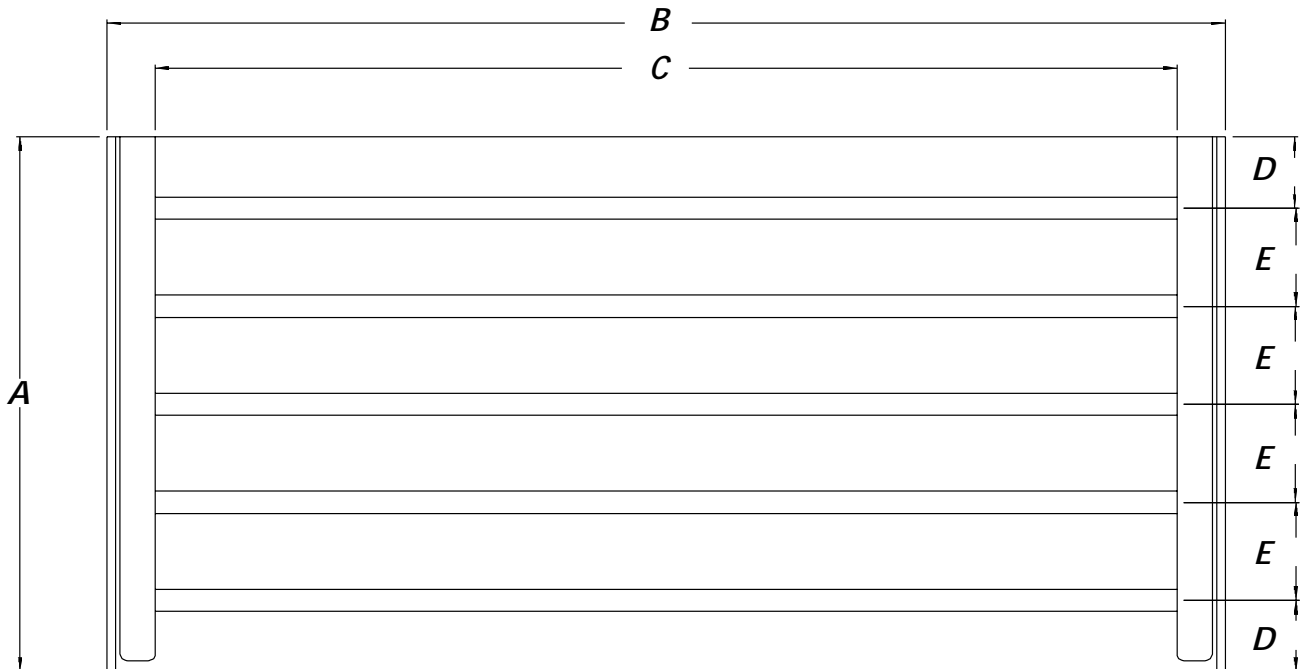

Figure 1-24 6030 Table

A = 30.00" (762mm) B = 63.50" (1612.9mm) C = 58.00" (1473.2mm)
 D = 4.00" (101.6mm) E = 5.50" (139.7mm)

8030 Table

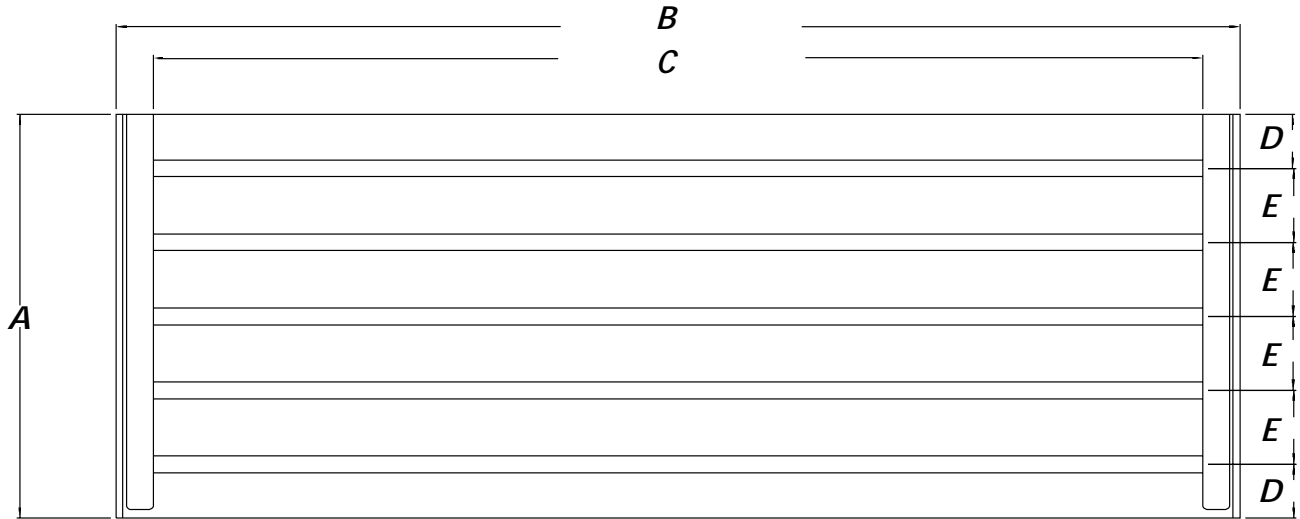

Figure 1-25 8030 Table

A = 30.00" (762mm) B = 83.50" (2120.9mm) C = 78.00" (1981.2mm)
 D = 4.00" (101.6mm) E = 5.50" (139.7mm)

6535 Table

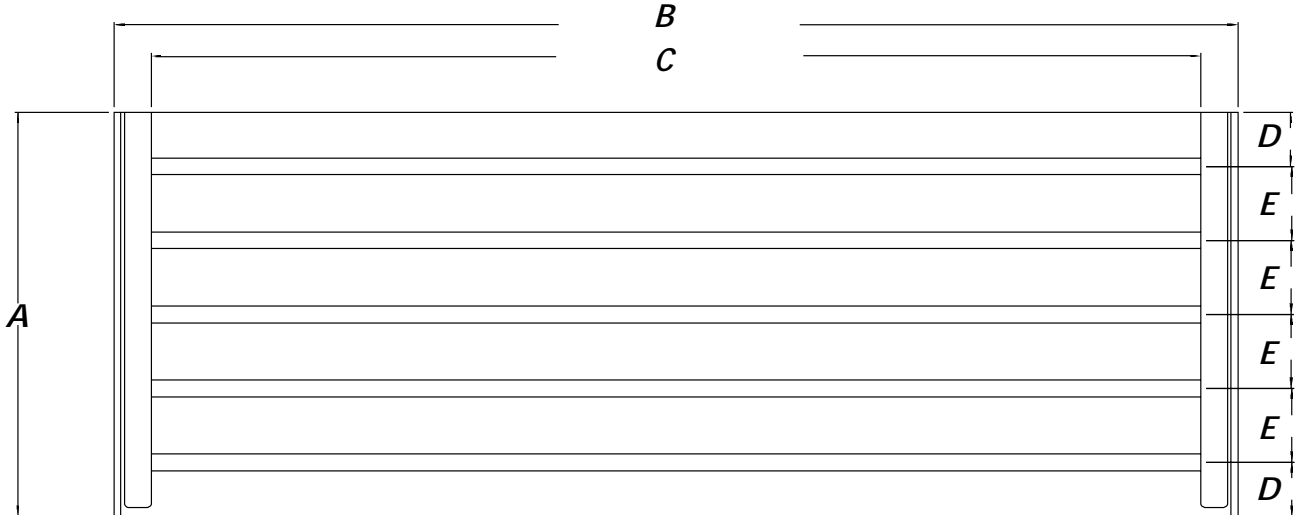

Figure 1-26 6535 Table

A = 35.00" (889mm) B = 74.76" (1899mm) C = 69.50" (1765mm)
 D = 2.74" (70mm) E = 4.92" (125mm)

TRM T-Slots

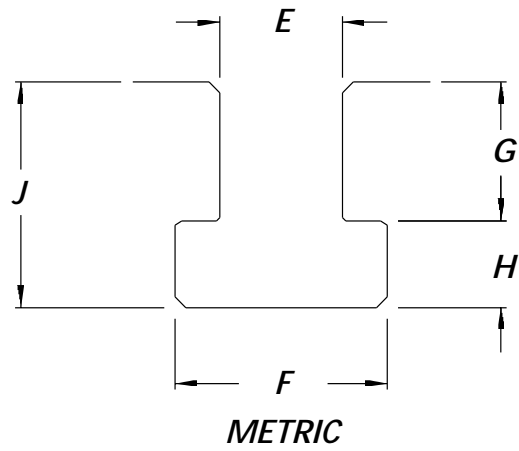

Figure 1-27 TRM T-Slots

Metric T-Slots:

E = 14.28-14.33mm

F = 24.6mm

H = 10mm

G = 15.9mm

J = 25.9mm

**4020, 4020A,
5020A, 6030 & 8030
T-Slots**

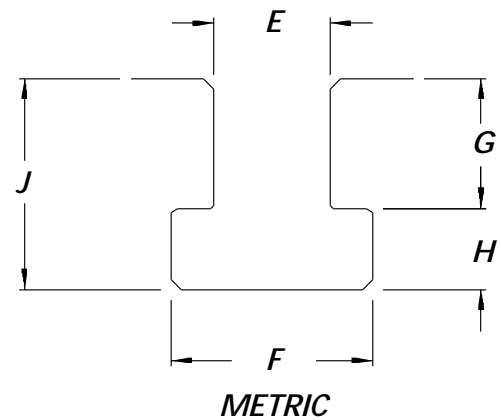
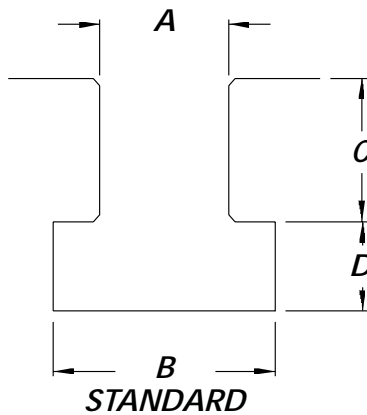

Figure 1-28 4020, 4020A, 5020A, 6030 & 8030 T-Slots

Standard T-Slots:

A = .6875-.6895" (17.46-17.51mm) B = 1.250" (31.75mm)
 C = .70" (17.78mm) D = .485" (12.32mm)

Metric T-Slots:

E = .7085-.7100" (17.996-18.034mm)
 F = 1.19-1.25" (30.23-31.75mm) G = .787" (19.99mm)
 H = .482-.542" (12.24-13.77mm) J = 1.299" (32.995mm)

**3020, 4525, 6535
T-Slots**

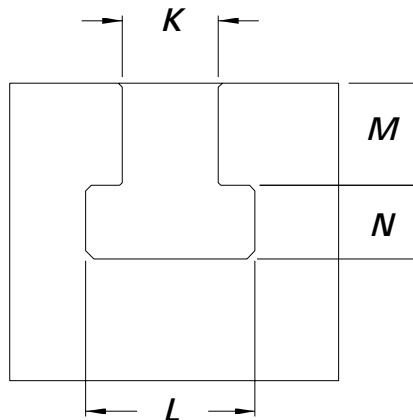

3020, 4525, 6535 T-Slots:

K = .7086-.7093" (17.998-18.016mm) L = 1.19" (30.23mm)
 M = .817" (20.75mm) N = .482" (12.24mm)

Recommended Mainline Fuses / Circuit Breakers

Table 15: Recommended Fuses

Spindle Type	208 V 3 Phase	240 V 3 Phase	380-415 V 3 Phase	480 V 3 Phase	240 V Single Phase
5 HP	30A	30A	30A	30A	50A
10 HP	50A	50A	35A	25A	70A
HT	70A	70A	35A	35A	90A
VHT	N/A	90A	70A (SIEMENS)	N/A	N/A
50 Taper	N/A	N/A	70A	70A	N/A

Table 16: Circuit Breakers for the New Sheet Metal

Spindle Type	208 V 3 Phase	240 V 3 Phase	380-415 V 3 Phase	480 V 3 Phase	240 V Single Phase
5 HP	30A	30A	30A	30A	50A
10 HP	50A	50A	35A	25A	70A
HT	70A	70A	35A	35A	90A
VHT	N/A	90A	70A	N/A	N/A
50 Taper	N/A	N/A	70A	70 A	N/A
3 HP	N/A	30A	N/A	N/A	30A

Table 17: Electrical Service Circuit Breaker

Spindle Type	208 V 3 Phase	240 V 3 Phase	380-415 V 3 Phase	480 V 3 Phase	240 V Single Phase
5 HP	30 A	30 A	30 A	30 A	50 A
10 HP	50 A	40 A	25 A	25 A	60 A
HT	70 A	45 A	35 A	25 A	60 A
VHT	N/A	90 A	70 A	N/A	N/A
50-Taper	N/A	N/A	70 A	70 A	N/A

Note: VHT runs only on 220-240V. External transformer required for any other voltage.