

Operation/Programming 11/2002 Edition

sinumerik

ShopMill
SINUMERIK 840D/840Di/810D

SIEMENS

SIEMENS

SINUMERIK 840D/840Di/810D

ShopMill

Operation/Programming

Valid for

<i>Control</i>	<i>Software version</i>
SINUMERIK 840D	6
SINUMERIK 840DE (export version)	6
SINUMERIK 840D powerline	6
SINUMERIK 840DE powerline	6
SINUMERIK 840Di	2
SINUMERIK 840DiE (export version)	2
SINUMERIK 810D powerline	6
SINUMERIK 810DE powerline	6

11.02 Edition

Introduction	1
Operation	2
Programming with ShopMill	3
Programming with G Code	4
Simulation	5
File Management	6
Alarms and Messages	7
Examples	8
Appendix	A

SINUMERIK® Documentation

Printing history

Brief details of this edition and previous editions are listed below.

The status of each edition is shown by the code in the "Remarks" column.

Status codes in the "Remarks" column:

- A** New documentation.
- B** Unrevised edition with new Order No.
- C** Revised edition with new status.

Edition	Order No.	Comment
10.97	6FC5298-2AD10-0BP0	A
11.98	6FC5298-2AD10-0BP1	C
03.99	6FC5298-5AD10-0BP0	C
08.00	6FC5298-5AD10-0BP1	C
12.01	6FC5298-6AD10-0BP0	C
11.02	6FC5298-6AD10-0BP1	C

This book is part of the documentation available on CD-ROM (**DOCONCD**)

Edition	Order No.	Comment
11.02	6FC5298-6CA00-0BG3	C

Trademarks

SIMATIC®, SIMATIC HMI®, SIMATIC NET®, SIROTEC®, SINUMERIK® and SIMODRIVE® are trademarks of Siemens AG. Other product names in this documentation may be trademarks which, if used by third parties, could infringe the rights of their owners.

Further information is available on the Internet under:
<http://www.ad.siemens.de/sinumerik>

This publication was produced with WinWord V8.0 and Designer V6.0.

The reproduction, transmission or use of this document or its contents is not permitted without express written authority. Offenders will be liable for damages. All rights, including rights created by patent grant or registration of a utility model or design, are reserved.

© Siemens AG, 1997–2002. All rights reserved

Other functions not described in this documentation might be executable in the control. This does not, however, represent an obligation to supply such functions with a new control or when servicing.

We have checked that the contents of this document correspond to the hardware and software described. Nonetheless, differences might exist and we cannot therefore guarantee that they are completely identical. The information contained in this document is, however, reviewed regularly and any necessary changes will be included in the next edition. We welcome suggestions for improvement.

Subject to change without prior notice

Preface

Structure of the documentation	<p>The SINUMERIK documentation is organized in 3 parts:</p> <ul style="list-style-type: none">• General Documentation• User Documentation• Manufacturer/Service Documentation
Target group	<p>This documentation is intended for use by operators of vertical machining centers or universal milling machines controlled by the SINUMERIK 840D/840Di/810D system.</p>
Validity	<p>This Operator's/Programming Guide is valid for ShopMill SW 6.3 with</p> <ul style="list-style-type: none">• SINUMERIK 810D (SW 6.3 and later)• SINUMERIK 840D (SW 6.3 and later)• SINUMERIK 840Di (SW 2.2 and later)
Hotline	<p>Please address any queries to the following hotline: A&D Technical Support Tel.: +49 (0) 180 5050-222 Fax: +49 (0) 180 5050-223 Email: adsupport@siemens.com</p> <p>If you have any queries (suggestions, corrections) concerning the documentation, please send them to the following fax number or email address: Fax: +49 (0) 9131 98-2176 Fax form at the end of the documentation Email: motioncontrol.docu@erlf.siemens.de</p>
Internet address	<p>http://www.ad.siemens.de/sinumerik</p>
SINUMERIK 840D powerline	<p>As of 09.2001, improved-performance variants SINUMERIK 840D powerline and SINUMERIK 840DE powerline are available. For a list of available powerline modules, please refer to the following Hardware Description: Reference: /PHD/, SINUMERIK 840D Configuration Manual</p>
SINUMERIK 810D powerline	<p>As of 12.2001, improved-performance variants SINUMERIK 810D powerline and SINUMERIK 810DE powerline are available from. For a list of available powerline modules, please refer to the following Hardware Description: Reference: /PHC/, SINUMERIK 810D Configuration Manual</p>
Standard scope	<p>This Operator's/Programming Guide describes the functionality of the ShopMill operator interface. Extensions or changes made by the machine tool manufacturer are documented by the machine tool manufacturer.</p>

More detailed information about other publications relating to SINUMERIK 840D/840Di/810D and publications that apply to all SINUMERIK controls (e.g. Universal Interface, Measuring Cycles...) can be obtained from your local Siemens branch office.

Other functions not described in this documentation might be executable in the control. This does not, however, represent as obligation to supply such functions with a new control or when servicing.

Principle

Your SIEMENS 840D/840Di/810D with ShopMill has been designed and constructed according to state-of-the-art technology and approved safety regulations and standards.

Additional equipment

SIEMENS offers special add-on equipment, products and system configurations for the focused expansion of SIEMENS controls in your field of application.

Personnel

Only **suitably trained, authorized, reliable personnel** should be allowed to handle the equipment. Persons who are not qualified should never be allowed to work on the control, even for a short time.

The relevant **responsibilities** of personnel who set up, operate and maintain the equipment must be clearly **defined** and adherence to these responsibilities **monitored**.

Procedure

Before the control is started up, it should be ensured that the Operator's Guides have been read and understood by the people responsible. The operator also has a **permanent obligation to continuously monitor** the overall technical condition (externally recognizable defects and damage and changes in the operating behavior) of the control.

Servicing

Repairs must be carried out by personnel who are **specially trained and qualified** in the relevant technical subject according to the information supplied in the service and maintenance guide. All appropriate safety specifications must be observed.

The following is deemed to be **improper usage** and **exempts the manufacturer from any liability**:

- **Any** application deviating from the above points or usage extending beyond the given limits.
- Cases where the control is **not maintained in perfect technical condition**, or is operated without due regard to safety or danger, and cases where any or all of the instructions in the Operator's Guide have not been observed.
- If faults that might affect the safety of the equipment are not



rectified **before** the control is started up.

- Any **modification, bypassing** or **disabling** of items of equipment on the control that are required to ensure fault-free operation, unlimited use and active and passive safety.

Improper usage gives rise to **unforeseen dangers** to

- life and limb of personnel,
- the control, machine or other assets of the owner and the user.

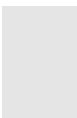

Structure of the documentation

This documentation uses the following information blocks, identified by pictograms:



Function



Operating sequence



Explanation of parameters



Additional notes



Software option

The function described is a software option. This means that the function will only run on the control if you have purchased the relevant option.

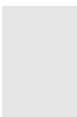

Warnings

The following 5 warnings with varying degrees of severity are used in this documentation.



Danger

This symbol indicates that death, grievous injury or substantial property damage **will** occur if the appropriate precautions are not taken.



Warning

This symbol indicates that death, grievous injury or substantial property damage **may** occur if the appropriate precautions are not taken.



Caution

This symbol indicates that minor injuries or property damage **may** occur if the appropriate precautions are not taken.

Caution

This warning (without a warning triangle) indicates that property damage **may** occur if the appropriate precautions are not taken.

Attention

This warning indicates that an undesired event or state **may** occur if the appropriate precautions are not taken.

Machine manufacturer

If changes or additions exist for a particular topic, they are referenced here:

Please observe the details provided by the machine manufacturer.

References

Further references for particular topics are indicated here:

Reference:

A complete list of available literature is included in the Appendix of this Operator's Guide.

Terms

The meanings of several fundamental terms used in this documentation are defined below:

Program

A program is a sequence of instructions for the CNC control, which produce a particular workpiece at the machine.

Contour

A contour outlines a workpiece.

The term "contour" is also used to denote the section of a program that uses individual elements to define the outline of a workpiece.

Cycle

A cycle, for example, mill rectangular pocket, is a subroutine specified by ShopMill to execute a repetitive machining process.

(a cycle is sometimes also called a "function".)

"Unit of measurement"

The parameter units are always specified in metric units in this documentation. The corresponding inch measures are given in the table below.

Metric	Inch
mm	in
mm/tooth	in/tooth
mm/min	in/min
mm/rev	in/rev
m/min	ft/min

Notes

Contents

Introduction	1-17
1.1 The ShopMill product	1-18
1.2 Workstation	1-19
1.2.1 Operator panels	1-19
1.2.2 Operator panel keys	1-22
1.2.3 Machine control panel	1-24
1.2.4 Elements on the machine control panels	1-24
1.2.5 Mini handheld unit	1-28
1.3 User interface	1-30
1.3.1 Overview	1-30
1.3.2 Operation via soft key and keys	1-32
1.3.3 Program views	1-36
1.3.4 Setting parameters	1-40
1.4 Fundamentals	1-42
1.4.1 Rectangular coordinate system	1-42
1.4.2 Plane designations	1-42
1.4.3 Polar coordinates	1-43
1.4.4 Absolute dimension	1-44
1.4.5 Incremental dimension	1-44
1.4.6 Pocket calculator function	1-45
1.4.7 Inch/metric dimension system switchover	1-46
1.4.8 Switchover between machine and workpiece coordinate systems	1-47
Operation	2-49
2.1 Power ON and reference point approach	2-51
2.1.1 User confirmation with Safety Integrated	2-54
2.2 Manual mode and settings for manual mode	2-55
2.2.1 Traverse the machine axes	2-55
2.2.2 Load tool from list into spindle	2-56
2.2.3 Enter a new tool in the list and load it to the spindle	2-57
2.2.4 Enter a new tool in the list and load it in the magazine	2-58
2.2.5 Start, stop and position the spindle manually	2-58
2.2.6 Machine-specific functions	2-60
2.2.7 Switch over machining plane/tool axis	2-60
2.2.8 Switch over to mm or inches	2-61
2.3 Set a new position value	2-62
2.4 Measure workpiece zero	2-64
2.4.1 Manual measurement	2-64
2.4.2 Automatic measurement	2-69
2.4.3 Calibrate electronic measuring tool	2-74
2.5 Measure tools	2-76
2.5.1 Measure tool manually	2-76

2.5.2	Measuring tools with a probe.....	2-78
2.5.3	Calibrate measuring probe	2-81
2.6	Machining in Manual mode.....	2-82
2.6.1	Change settings.....	2-82
2.6.2	Positioning	2-83
2.6.3	Face milling	2-83
2.7	MDI mode.....	2-85
2.8	Automatic mode	2-86
2.8.1	Switchover between "T, F, S", "G functions" and "Auxiliary functions" displays	2-87
2.8.2	Select a program for execution	2-88
2.8.3	Start/stop/abort program	2-89
2.8.4	Interrupt program.....	2-90
2.8.5	Start execution at specific program location.....	2-91
2.8.6	Program control.....	2-94
2.8.7	Program testing	2-95
2.8.8	Simultaneous recording before machining	2-96
2.8.9	Simultaneous recording during machining	2-97
2.9	Execute a trial program run.....	2-98
2.9.1	Single block	2-98
2.9.2	Basic block display	2-99
2.9.3	Correct program	2-100
2.10	Tools and tool offsets	2-101
2.10.1	Create a new tool	2-105
2.10.2	Create several cutting edges per tool.....	2-106
2.10.3	Change the tool name	2-107
2.10.4	Create a replacement tool	2-107
2.10.5	Manual tools	2-107
2.10.6	Tool offsets.....	2-108
2.10.7	Special tool functions.....	2-111
2.10.8	Create tool wear data	2-112
2.10.9	Tool monitoring.....	2-113
2.10.10	Magazine list.....	2-114
2.10.11	Delete a tool	2-115
2.10.12	Change the tool type	2-115
2.10.13	Load a tool.....	2-116
2.10.14	Unload a tool	2-117
2.10.15	Sort tools	2-118
2.11	Work offsets	2-119
2.11.1	Defining a work offset.....	2-121
2.11.2	Work offset list.....	2-122
2.11.3	Select/deselect work offset in the Manual area.....	2-124
2.12	Switching to CNC ISO operation	2-125
2.13	ShopMill Open (PCU 50).....	2-126
2.14	Remote diagnosis.....	2-126

Programming with ShopMill	3-127
3.1	Fundamental programming principles..... 3-129
3.2	Program structure 3-132
3.3	Create a ShopMill program 3-133
3.3.1	Create new program; define a blank 3-133
3.3.2	Program new blocks..... 3-136
3.3.3	Change program blocks 3-138
3.3.4	Program editor 3-139
3.4	Program the tool, offset value and spindle speed 3-142
3.5	Contour milling 3-143
3.5.1	Free contour programming 3-144
3.5.2	Description of soft keys for free contour programming function 3-147
3.5.3	Description of parameters for line/circle contour elements 3-149
3.5.4	Programming examples for freely defined contours 3-150
3.5.5	Path milling of open and closed contours 3-153
3.5.6	Rough drilling in contour pockets 3-156
3.5.7	Machine (rough cut) pocket with islands 3-159
3.5.8	Remove residual material 3-160
3.5.9	Finish pocket with islands 3-162
3.6	Straight line or circular path motions 3-164
3.6.1	Line..... 3-165
3.6.2	Circle with known center point 3-167
3.6.3	Circle with known radius 3-168
3.6.4	Helix 3-169
3.6.5	Polar coordinates 3-170
3.6.6	Polar line 3-171
3.6.7	Polar circle 3-172
3.6.8	Programming examples for polar coordinates 3-173
3.7	Drilling 3-174
3.7.1	Centering..... 3-175
3.7.2	Drilling and reaming 3-176
3.7.3	Deep-hole drilling 3-177
3.7.4	Boring 3-179
3.7.5	Tapping 3-180
3.7.6	Thread cutting 3-181
3.7.7	Drill and thread milling..... 3-184
3.7.8	Position on freely programmable positions and position patterns..... 3-186
3.7.9	Freely programmable positions..... 3-187
3.7.10	Line position pattern 3-188
3.7.11	Matrix position pattern..... 3-189
3.7.12	Full circle position pattern 3-190
3.7.13	Pitch circle position pattern 3-192
3.7.14	Obstacle 3-193
3.7.15	Repeat positions 3-194

3.7.16	Programming examples for drilling.....	3-195
3.8	Milling	3-197
3.8.1	Face milling	3-197
3.8.2	Rectangular pocket	3-200
3.8.3	Circular pocket	3-204
3.8.4	Rectangular spigot.....	3-207
3.8.5	Circular spigot.....	3-209
3.8.6	Mill longitudinal slot	3-212
3.8.7	Circumferential slot.....	3-214
3.8.8	Use of position patterns for milling	3-216
3.9	Measurements.....	3-219
3.9.1	Measure workpiece zero	3-219
3.9.2	Measure tool.....	3-221
3.9.3	Calibrate the measuring probe	3-222
3.10	Miscellaneous functions	3-223
3.10.1	Call subroutine.....	3-223
3.10.2	Repeat program blocks	3-224
3.10.3	Change program settings	3-226
3.10.4	Call work offsets	3-227
3.10.5	Define coordinate transformation	3-228
3.10.6	Cylinder peripheral surface transformation	3-231
3.10.7	Swiveling	3-234
3.10.8	Miscellaneous functions	3-239
3.11	Insert G code in the ShopMill program.....	3-240
Programming with G Code		4-243
4.1	Create a G code program.....	4-244
4.2	Execute G code program	4-247
4.3	G code editor	4-249
4.4	Arithmetic parameters	4-252
4.5	ISO dialects	4-253
Simulation		5-255
5.1	General.....	5-256
5.2	Start/abort program	5-256
5.3	Representation as a plan view	5-258
5.4	Representation as a 3-plane view	5-259
5.5	Zoom a finished part viewport	5-260
5.6	Three-dimensional representation of finished part.....	5-261
5.6.1	Change position of finished part.....	5-261
5.6.2	Cut open finished part	5-262
5.6.3	Update finished part display	5-262

File Management	6-263
6.1	Manage programs with ShopMill 6-264
6.2	Manage programs with PCU 20 6-265
6.2.1	Open program 6-267
6.2.2	Execute a program 6-268
6.2.3	Multiple clamping 6-268
6.2.4	Execute G code program from floppy disk drive or network drive 6-271
6.2.5	Create new directory/program 6-272
6.2.6	Select several programs 6-273
6.2.7	Copying/renaming directories/programs 6-274
6.2.8	Deleting directories/programs 6-275
6.2.9	Execute program via RS-232 interface 6-276
6.2.10	Read program in/out via RS-232 interface 6-277
6.2.11	Display error log 6-279
6.2.12	Save/read in tool data/zero point data 6-279
6.3	Manage programs with PCU 50 6-282
6.3.1	Open program 6-284
6.3.2	Execute a program 6-285
6.3.3	Multiple clamping 6-286
6.3.4	Loading/unloading program 6-288
6.3.5	Execute G code program from hard disk, floppy disk drive or network drive 6-289
6.3.6	Create new directory/program 6-291
6.3.7	Select several programs 6-292
6.3.8	Copying/renaming/moving directories/programs 6-293
6.3.9	Deleting directories/programs 6-295
6.3.10	Execute program via RS-232 interface 6-296
6.3.11	Display error log 6-298
6.3.12	Save/read in tool data/zero point data 6-298
Alarms and Messages	7-301
7.1	Cycle alarms and messages 7-302
7.1.1	Error treatment in cycles 7-302
7.1.2	Cycle alarm overview 7-302
7.1.3	Messages in cycles 7-307
7.2	Alarms for ShopMill 7-308
7.2.1	Alarm overview 7-308
7.2.2	Select the alarm/message overview 7-309
7.2.3	Description of alarms 7-310
7.3	User data 7-318
7.4	Version display 7-320
Examples	8-321
8.1	Example 1: Machine with rectang./circ. pocket and circumf. slot 8-322
8.2	Example 2: Shift and mirror a contour 8-330

8.3	Example 3: Chamfer on circular spigot	8-333
8.4	Example 4: Cylinder surface transformation	8-336
8.5	Example 5: Slot side compensation	8-340
8.6	Example 6: Swiveling	8-344
Appendix		A-351
A	Abbreviations	A-352
B	References	A-355
C	Index	A-369

Introduction

1.1	The ShopMill product	1-18
1.2	Workstation	1-19
1.2.1	Operator panels	1-19
1.2.2	Operator panel keys	1-22
1.2.3	Machine control panel	1-24
1.2.4	Elements on the machine control panels	1-24
1.2.5	Mini handheld unit	1-28
1.3	User interface	1-30
1.3.1	Overview	1-30
1.3.2	Operation via soft key and keys	1-32
1.3.3	Program views	1-36
1.3.4	Setting parameters	1-40
1.4	Fundamentals	1-42
1.4.1	Rectangular coordinate system	1-42
1.4.2	Plane designations	1-42
1.4.3	Polar coordinates	1-43
1.4.4	Absolute dimension	1-44
1.4.5	Incremental dimension	1-44
1.4.6	Pocket calculator function	1-45
1.4.7	Inch/metric dimension system switchover	1-46
1.4.8	Switchover between machine and workpiece coordinate systems	1-47

1.1 The ShopMill product

The ShopMill operating and programming software has been designed to perform 2½D milling operations on vertical and universal milling machinery with a maximum of 5 axes (including 2 rotary axes) and 1 spindle.

The recommended hardware base for ShopMill is a SINUMERIK 840D/840Di/810D with PCU 20 or PCU 50.

ShopMill has been designed such that machine users can learn quickly and easily how to operate and program the SINUMERIK 840D/840Di/810D CNC control system. The standard operator interface provides access to the full functional scope of the SINUMERIK 840D/840Di/810D. Workpieces are programmed graphically, i.e. the user does not need to have G code programming expertise.

Highlights

- Clear program overview in the machining plan
- Dynamic input graphics (programming graphics) for contour elements and cycles
- Simultaneous recording (option)
- Contour pocket cycles with residual material sensing and residual material machining (option)
- 3D graphics of finished part
- Optimum adjustment of tool traversing paths taking account of workpiece contour and obstacles
- Powerful contour computer for entry of freely defined contours
- Automatic generation of approach and retract motions depending on the tool position and machining type
- Network support and diskette drive connection (option)
- Support for inclinable heads and tilting tables
- Multiface machining, multiple clamping
- Remote diagnostics (option)
- Custom user screens - incl. cycle support

Before actuating any of the control elements on this panel:

Please read all the relevant explanations in this document carefully!



1.2 Workstation

1.2.1 Operator panels

OP 010 operator panel

Alternatively, you can also use one of the following operator panels for the PCUs:

OP 010

OP 010C

OP 010S with OP 032S full CNC keyboard

OP 012

OP 015 with full 19" CNC keyboard

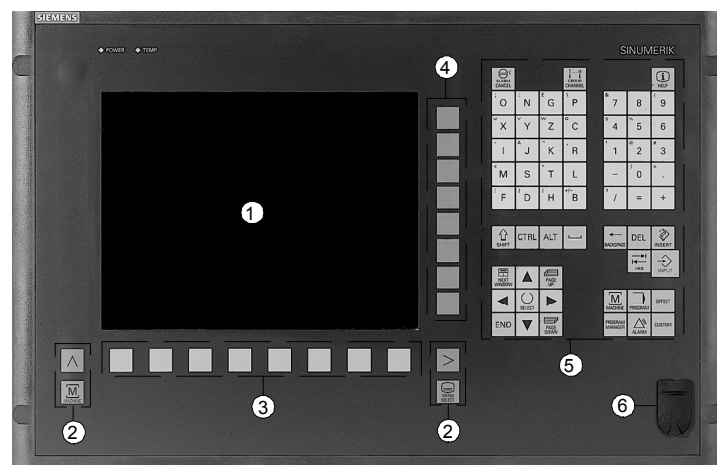

OP 010 operator panel

- 1 10" screen
- 2 Screen keys
- 3 Horizontal soft key bar
- 4 Vertical soft key bar
- 5 Alphanumerical keypad
Correction/cursor keypad with control keyboard and input key
- 6 USB interface

OP 010C operator panel

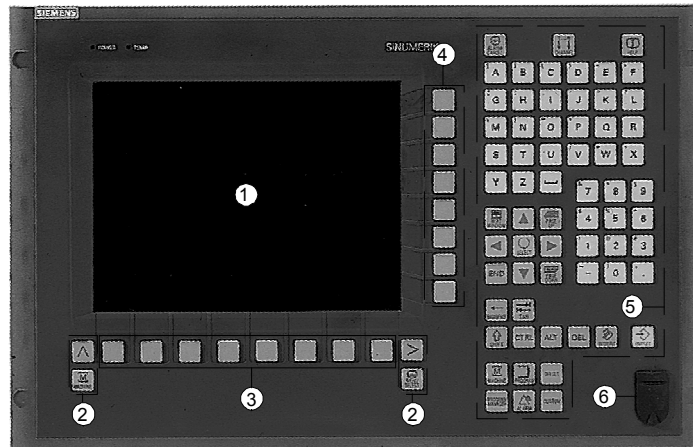

OP 010C operator panel

- 1 10" screen
- 2 Screen keys
- 3 Horizontal soft key bar
- 4 Vertical soft key bar
- 5 Alphanumerical keypad
Correction/cursor keypad with control keyboard and input key
- 6 USB interface

OP 010S slimline operator panel

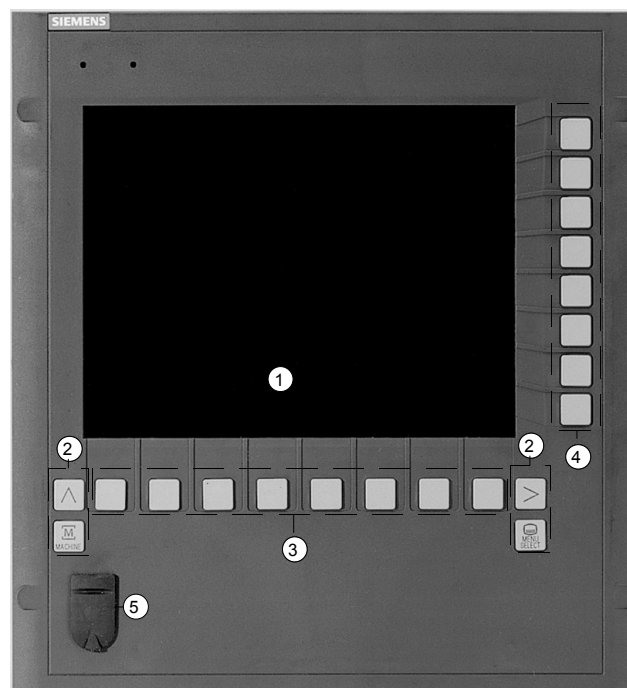

OP 010S operator panel

- 1 10" screen
- 2 Screen keys
- 3 Horizontal soft key bar
- 4 Vertical soft key bar
- 5 USB interface

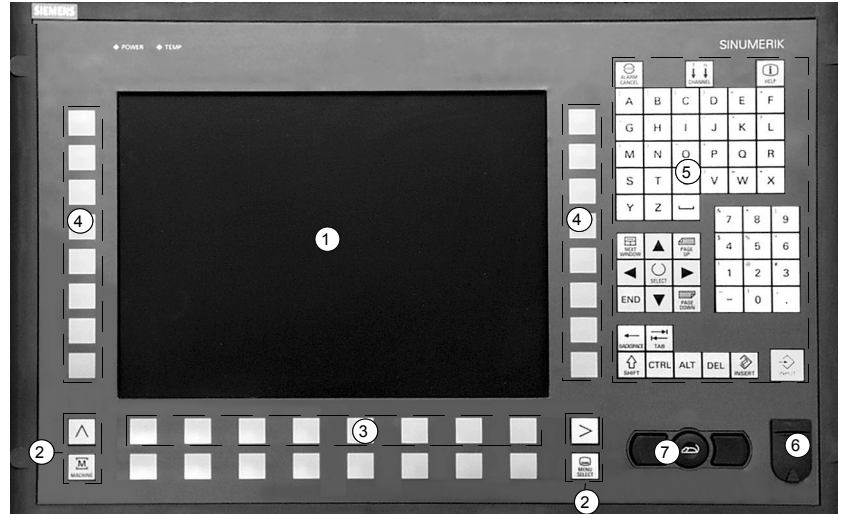
OP 012 operator panel*OP 012 operator panel*

- 1 12" screen
- 2 Screen keys
- 3 Horizontal soft key bar
- 4 Vertical soft key bar
- 5 Alphanumerical keypad
Correction/cursor keypad with control keyboard and input key
- 6 USB interface
- 7 Mouse

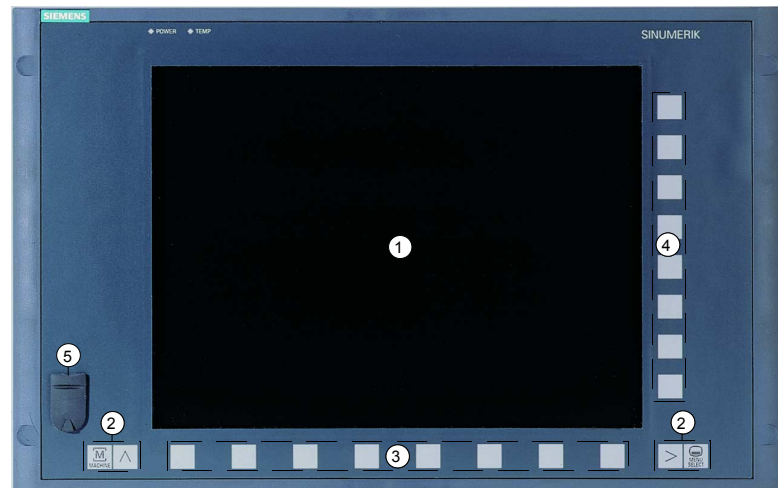
OP 015 operator panel*OP 015 operator panel*

- 1 15" screen
- 2 Screen keys
- 3 Horizontal soft key bar
- 4 Vertical soft key bar
- 5 USB interface

1.2.2 Operator panel keys



Alarm Cancel

Cancel the alarm that is characterized by this symbol.



Channel

Has no meaning for ShopMill.



Help

Change between machining plan and programming graphics as well as between parameter screen with programming graphics and parameter screen with help display.



Next Window

Has no meaning for ShopMill.



Page Up or Page Down

Page up or down in the directory or machining plan.



Cursor

Move between different fields or lines.

Cursor right opens a directory or program.

Cursor left changes to the next higher directory level.



Select

Select from several specified options.

This key corresponds to the "Alternative" soft key.



End

Move cursor to the last input field in a parameter screen.



Backspace

- Delete value in the input field.
- In insert mode, delete the character preceding the cursor.



Tab

Has no meaning for ShopMill.



Shift

Press the Shift key to output the characters at the top of the keys with dual assignment.



Ctrl

Used in the following key combinations in the machining plan and G code editor:

- Ctrl + Pos1: jump to beginning.
- Ctrl + End: jump to end.

Alt

Has no meaning for ShopMill.

Del - now with OP 031

- Delete value in the parameter field.
- In insert mode, deletes the character where the cursor is positioned.

Insert

Activate insert mode or pocket calculator.

Input

- Complete input of a value in the input field.
- Open a directory or program.

Alarm - OP 010 and OP 010C only

Invoke "Messages/Alarms" operating area.

This key corresponds to the "Messages/Alarms" soft key.

Program - OP 010 and OP 010C only

Invoke "Program" operating area.

This key corresponds to the "Program" soft key.

Offset - OP 010 and OP 010C only

Invoke "Tools/Work Offsets" operating area.

This key corresponds to the "Tools/Work Offset" soft key.

Program Manager - OP 010 and OP 010C only

Invoke "Program Manager" operating area.

This key corresponds to the "Program Manager" soft key.

1.2.3 Machine control panel

A SIEMENS machine control panel or a machine control panel supplied by the machine manufacturer can be connected to the turning machine.

For example, the standard machine control panel (19") or the slimline operator control panel OP 032S from SIEMENS.

You trigger actions on the turning machine from the machine control panel, e.g. traversing axes or machining the workpiece.

When the associated functions are active, the LEDs on the machine panel light up.

1.2.4 Elements on the machine control panels

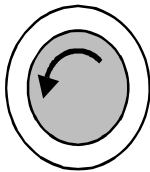

Emergency Stop button

Press pushbutton in emergency situations, i.e. if there is a threat to life or limb of an operator, or if the machine or the workpiece risk being damaged.

All drives are stopped with the greatest possible braking torque.

For more information about responses when activating the emergency stop button, please refer to the machine manufacturer's specifications.



Reset

- Execution of the active program is aborted.
The NC controller remains synchronized with the machine. It is in the initial setting and ready for the next program run.
- Delete alarm



Jog

Activate Machine Manual mode.



Teach In

Has no meaning for ShopMill.



MDI

Activate MDI mode.



Auto

Activate Machine Auto mode.



Single Block

Execute program non-modally (single block).

Repos

Repositioning, re-approach contour.

Ref Point

Approach reference point.

Inc Var (incremental feed variable)

Incremental feed with variable step sizes.

Inc (Incremental Feed)

Incremental feed with preset step size of 1, ..., 10000 increments.

The increment value is evaluated as a function of a machine data.

Please read the machine manufacturer's instructions.

Cycle Start

Start program execution.

Cycle Stop

Stop program execution.

Axis keys

Select axis.

Direction keys

Traverse axis in negative or positive direction.

Rapid

Traverse axis in rapid traverse (fastest speed).

WCS MCS

Switch between tool coordinate system (Work) and machine coordinate system (Machine).

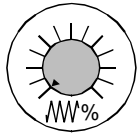

Feedrate/rapid traverse override

Increase or decrease programmed feed or rapid traverse.

The programmed feed or rapid traverse corresponds to 100% and can be set between 0% and 120%, in rapid traverse to a maximum of 100%.

The newly set feed is displayed in the feed status bar on the screen as an absolute value and as a percent value.



Feed Stop

Stop processing the active program and stop the axis drives moving.



Feed Start

Continue program execution in the current block and accelerate feed to the value set in the program.

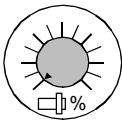

Spindle override

Decrease or increase programmed spindle speed.

The programmed spindle speed corresponds to 100% and can be set from 50 to 120%. The newly set spindle speed is displayed in the spindle status bar on the screen as an absolute value and as a percent value.



Spindle Dec. – OP032S machine control panel only

Decrease programmed spindle speed.



Spindle Inc. – OP032S machine control panel only

Increase programmed spindle speed.



100% – OP032S machine control panel only

Set programmed spindle speed again.



Spindle Stop

Stop the spindle.



Spindle Start

Start the spindle.



Spindle Left – machine control panel OP032S only

Start spindle (CCW rotation).



Spindle Right – machine control panel OP032S only

Start spindle (CW rotation).

Keyswitch

You can set different access rights via the keyswitch. The keyswitch has four settings with protection levels 4 to 7 assigned to them. Access to programs, data and functions can be disabled via machine data. You can set various levels of access protection.

Please read the machine manufacturer's instructions.

The keyswitch has three different-colored keys which you can remove in the specified positions:



Position 0
No key
Protection level 7



Position 1
Key 1 **black**
Protection level 6



Position 2
Key 1 **green**
Protection level 5



Position 3
Key 1 **red**
Protection level 4

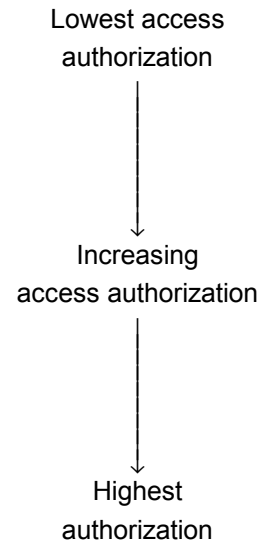

If you change the key position to modify the access authorization, you will not see the changes immediately on the screen. You first need to perform an action (e.g. open or close a directory).

If the PLC is in STOP state (LEDs on the machine control panel are flashing), ShopMill does not evaluate the keyswitch settings at boot.

The machine manufacturer can set protection levels 0 to 3 via a password. If this password is set, ShopMill does not assess the keyswitch setting.

Please read the machine manufacturer's instructions.



1.2.5 Mini handheld unit

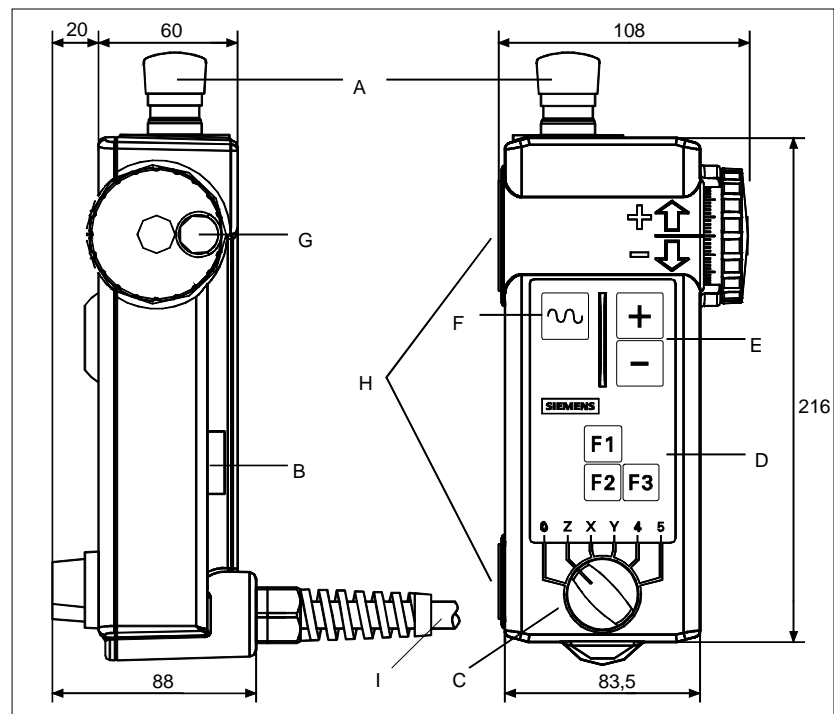

- A EMERGENCY STOP button, two-channel
- B Enabling key, two-channel
- C Axis selector switch for 5 axes and neutral position
- D Function keys F1, F2, F3
- E Traversing keys, directions +, –
- F Rapid traverse key for high-speed travel with traversing keys or handwheel
- G Handwheel
- H Magnets for attachment to metal parts
- I 1.5 m ... 3.5 m connecting lead

Control elements**EMERGENCY STOP button**

Use the EMERGENCY STOP button in urgent situations, i.e.

1. when human life is at risk or
2. if there is a risk of damage to the machine tool or workpiece.

Enabling key

The enabling key has 2 settings. It must be pressed to initiate traversing movements.

Axis selector switch

You can select up to 5 axes with the axis selector switch.

Function keys

You can activate machine-specific functions with the function keys.

Traversing keys

The + and – traversing keys can be pressed to move the axis selected with the axis selector switch.

Handwheel

The handwheel can be used to move the axis selected with the axis selector switch. The handwheel supplies 2 track signals with 100 I/V.

Rapid traverse key

The rapid traverse key increases the traversing speed of the axis selected with the axis selector switch. The rapid traverse key acts both on travel commands from the +/- keys and on the handwheel signals.

1.3 User interface

1.3.1 Overview

Screen layout

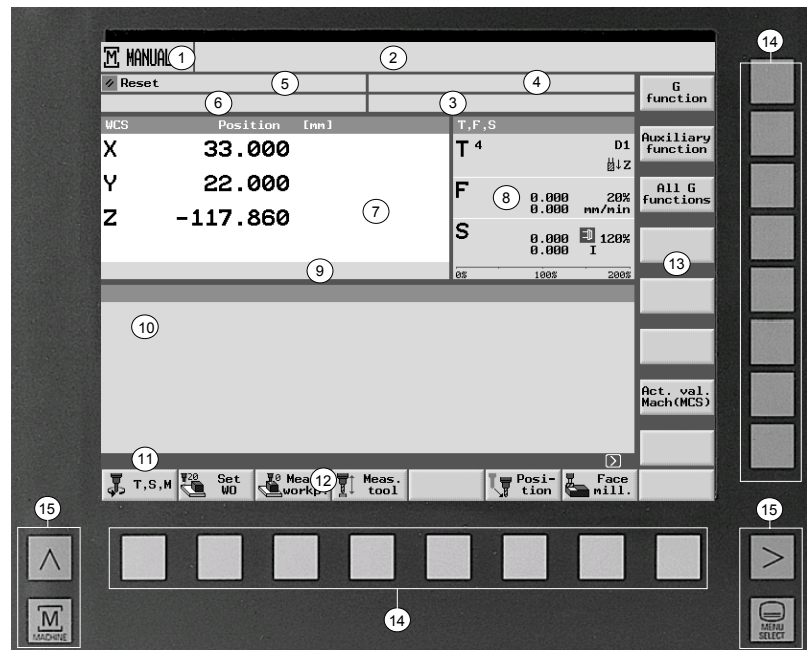



User interface

- 1 Active operating mode/operating area and sub-operating mode
- 2 Alarm and message line
- 3 Program name
- 4 Program path
- 5 Channel status and program control
- 6 Channel status messages
- 7 Position display for axes
- 8 Display for
 - active tool T
 - current feed F
 - spindle S
- 9 Display the active work offsets and rotation
- 10 Working window
- 11 Dialog line for additional explanations
- 12 Horizontal soft key bar
- 13 Vertical soft key bar
- 14 Soft keys
- 15 Screen keys

Submode

REF: Approach reference point
 REPOS: Repositioning
 INC1 ... INC10000: Fixed increment
 INC_VAR: Variable increment size



Channel status

 RESET
 active
 interrupted

Program control

SKP: Skip a G code block
 DRY: Dry run feed
 !ROV: Feedrate override only (not feedrate and rapid traverse override)
 SBL1: Single block (stop after each block that triggers a function on the machine)
 SBL2: Not possible to select in ShopMill (stop each every block)
 SBL3: Single block fine (stop after each block, even within the same cycle)
 M01: Programmed stop
 DRF: DRF offset
 PRT: Program test





Channel status messages

 Hold: Operator action is necessary.
 Wait: No operator action is necessary.

Feed status

 Feed not enabled

Spindle status

 Spindle not enabled
 Spindle motionless
 Spindle rotating CW
 Spindle rotating CCW



The symbols are color-coded as follows:
 Red: Machine is not running
 Green: Machine is running
 Yellow: Waiting for operator action
 Gray: Other

Screen keys**Machine**

Call active operating mode (Machine Manual, MDI or Machine Auto).

**Return jump**

Has no meaning for ShopMill.



Expansion

Change horizontal soft key bar.



Menu Select

Call main menu:



Symbols defined by the machine manufacturer can be displayed instead of the program path (4). The program path is then displayed together with the program name (3).

Please read the machine manufacturer's instructions.



1.3.2 Operation via soft key and keys

The ShopMill user interface consists of different screens featuring eight horizontal and eight vertical soft keys. Operate the soft keys via the keys positioned next to the soft keys.

Upon activation of a soft key, a new screen opens.

ShopMill has 3 operating modes (Machine Manual, MDI and Machine Auto) and 4 operating areas (Program Manager, Program Messages/Alarms and Tools/Work Offsets).

If you want to switch from one operating mode/operating area to another operating area, press the "Menu Select" key. The main menu is opened and you can select the required operating area by pressing the associated soft key.



Alternatively, you can access the operating areas via the keys on the operator panel.



You can select an operating mode at any time directly via the keys on the machine control panel.

If you press the "Machine" soft key in the main menu, the screen belonging to the currently active operating mode opens.

If you select another operating mode or another operating area, both the horizontal and the vertical soft key bar change.

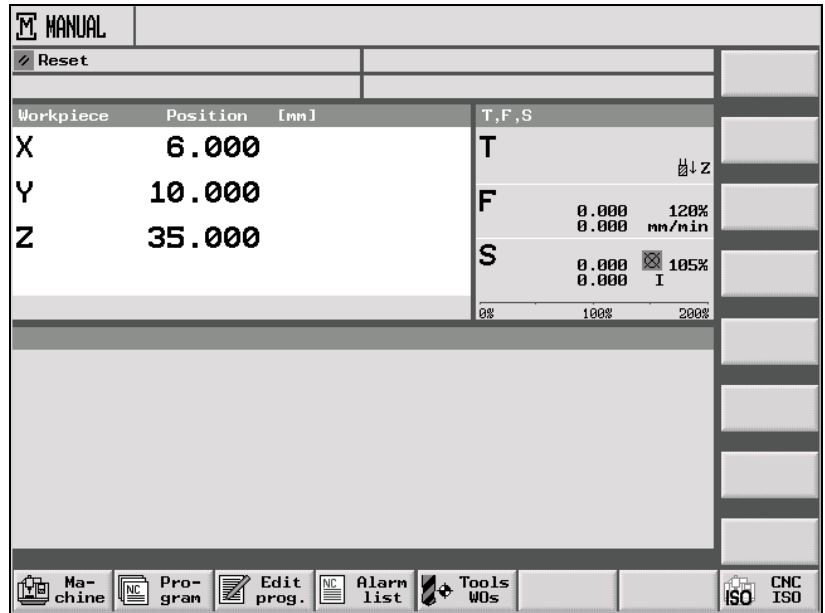

Main menu

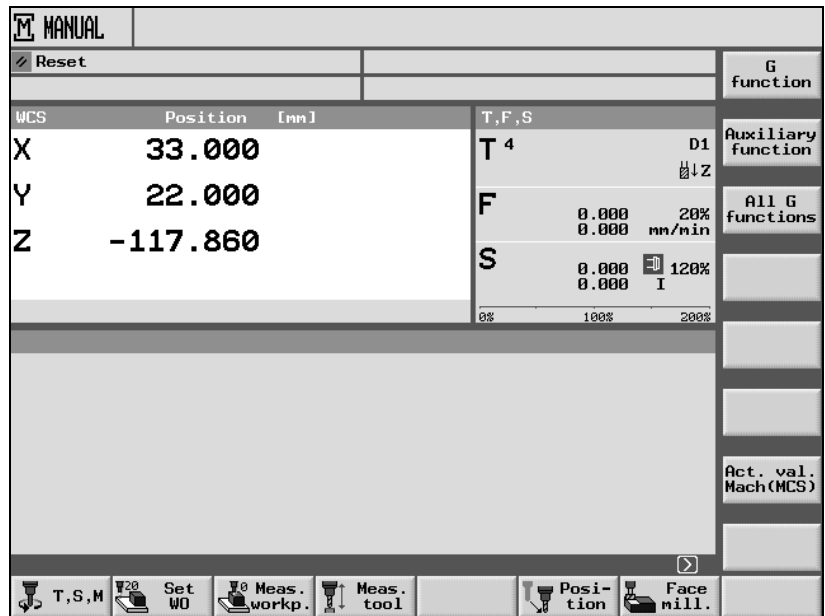

Machine Manual mode

If you activate a horizontal soft key within an operating mode or operating area, only the vertical soft key bar changes.

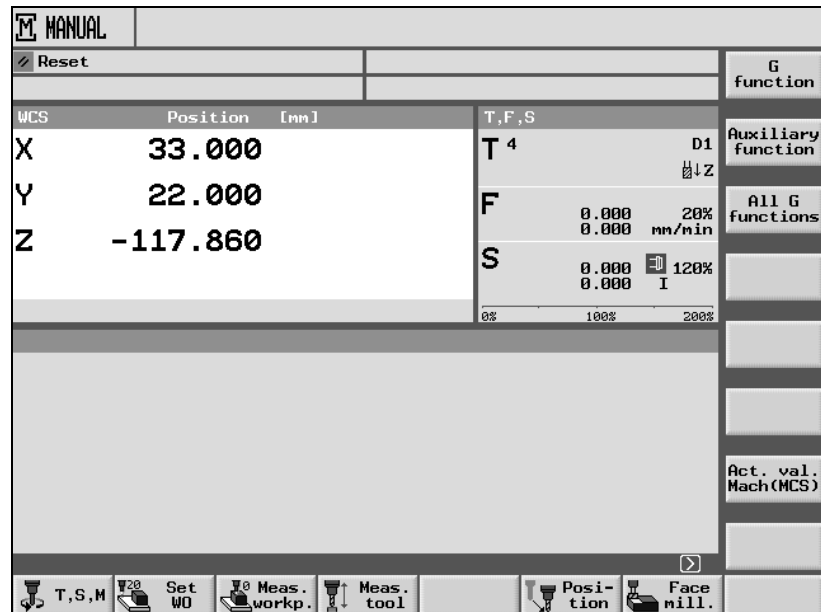

Machine Manual mode

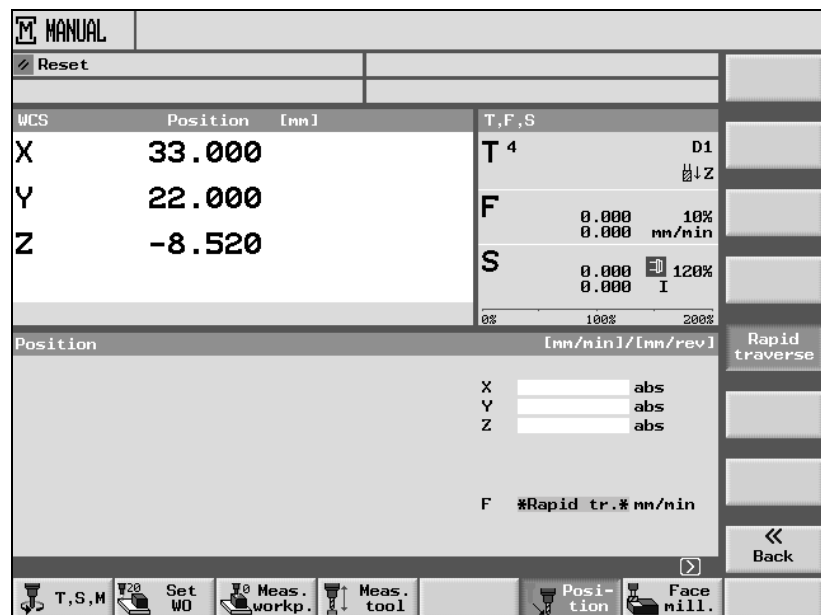

Function within Machine Manual mode



If the symbol  is displayed on the operator interface on the right of the dialog line, you can change the horizontal soft key bar within an operating area. To do this, press the "Expansion" soft key. If you press the "Expansion" soft key again, the original horizontal soft key bar is displayed again.



To return to a next-level screen within an operating mode/operating area, press the "Back" soft key.



Press the "Cancel" soft key to exit a screen without accepting the specified values and return to the next-level screen.



If you have entered all the necessary parameters correctly in the parameter screen, press the "Accept" soft key to close the screen and validate the data.



Pressing the "OK" soft key will trigger an immediate action, e.g. rename or delete a program.



ON

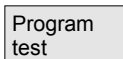

OFF

When some soft key functions are activated, the soft key background color will change to black to indicate the function in ON.

To deactivate the function again, press the soft key again. The soft key will be gray again.

1.3.3 Program views

Program manager

You can display a ShopMill program in various views.

All the programs are administered in the Program Manager. You also use the Program Manager to select a program for workpiece machining.

DIRECTORY				
Name	Type	Loaded	Size	Date/time
SHOPMILL.WPD\..				
T_011_TMZ	INI		6236	27.09.2002 09:14
UP_11_1_TMZ	INI		273	27.09.2002 09:14
T_011	MPF	X	5882	27.09.2002 10:52
T_012	MPF		215	27.09.2002 09:14
UP_11_1	MPF	X	1352	27.09.2002 10:52
UP_11_2	MPF	X	1060	27.09.2002 10:52
Free memory Hard disk : 1.2 GBytes NC: 458264				
NC				

Program Manager

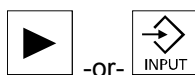

Select the Program Manager by activating the "Program" soft key or the "Program Manager" key.

You can navigate within a directory by pressing the "Cursor up" and "Cursor down" keys.

Use "Cursor right" to open a directory.

Use the "Cursor left" key to return to the next higher directory level.

Use the "Cursor right" or "Input" key to open the machining plan for a program.

Machining plan

The machining plan provides an overview of the individual machining steps in a program.

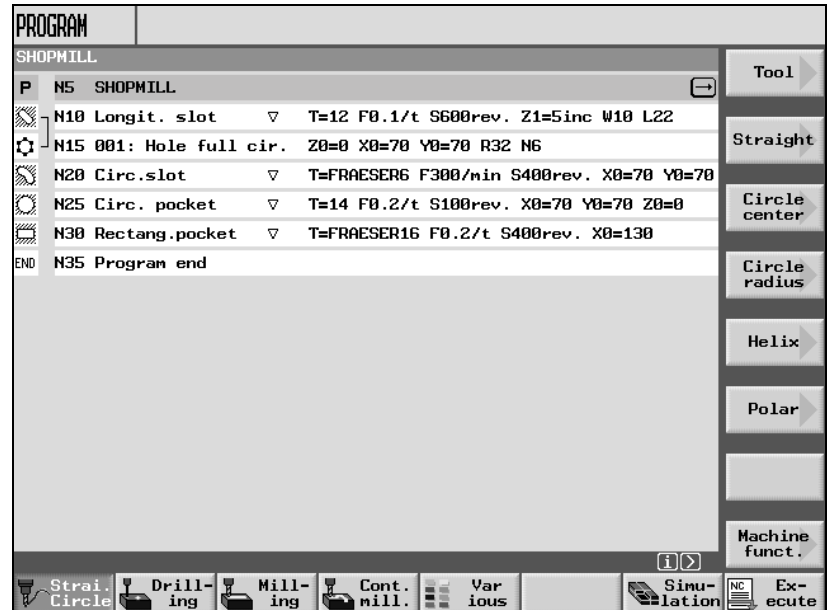

Machining plan



In the machining plan, you can use the "Cursor up" and "Cursor down" keys to navigate among the program blocks.

Use the "Help" key to switch between the machining plan and programming graphics.

Programming graphic

The programming graphics display a dynamic broken-line top view of the workpiece. The program block selected in the machining plan is highlighted in color in the programming graphics.

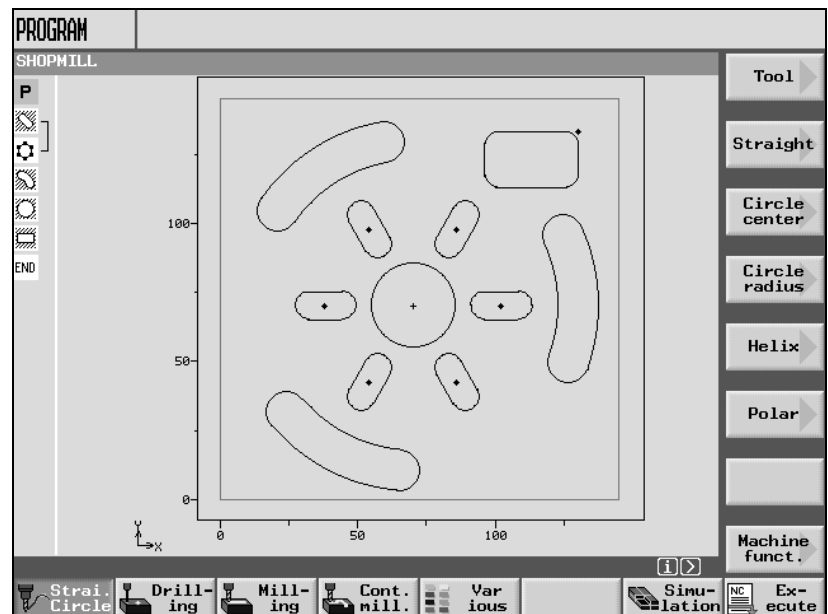

Programming graphic



Use the "Cursor right" key to open a program block in the machining plan. The associated parameter screen with programming graphics is opened.

Parameter screen with programming graphics

The programming graphics in the parameter screen show the contour of the active machining step as broken-line graphics as well as the parameters.

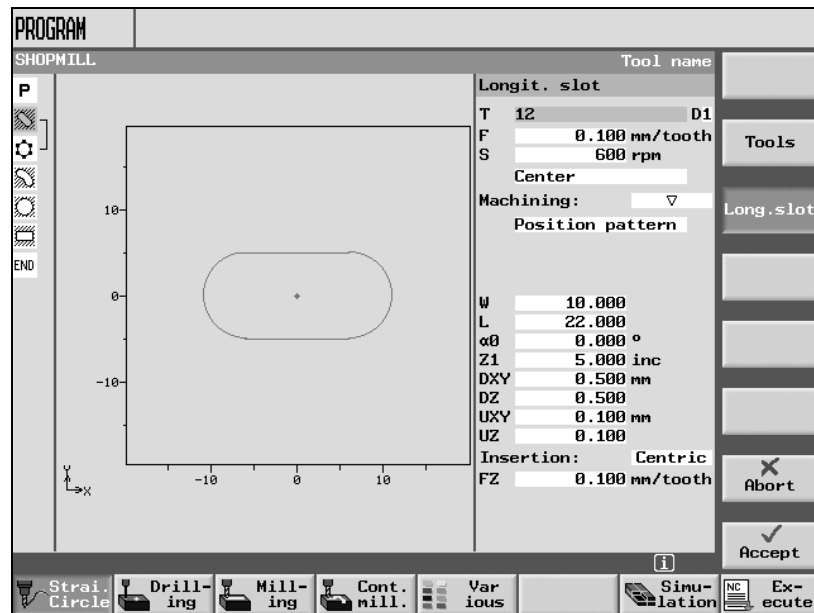

Parameter screen with programming graphics



You can use the cursor keys to navigate among the input fields in the parameter screen.



Press the "Help" key to change between programming graphics and the help display in the parameter screen.

Parameter screen with help display

The help display in the parameter screen provides information about the individual parameters in the machining step.

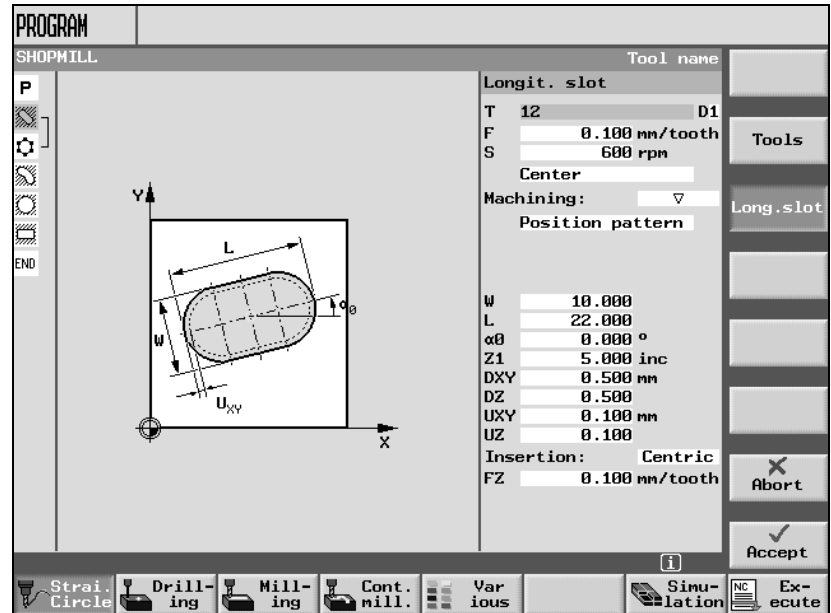

Parameter screen with help display

The color symbols in the help displays indicate the following:

Yellow circle = reference point

Red arrow = tool travelling in rapid traverse

Green arrow = tool travelling at machining feedrate

1.3.4 Setting parameters

When setting up the machine and programming, you need to specify values for specific parameters in the white input fields. Parameters that have a gray input field are automatically calculated by ShopMill.

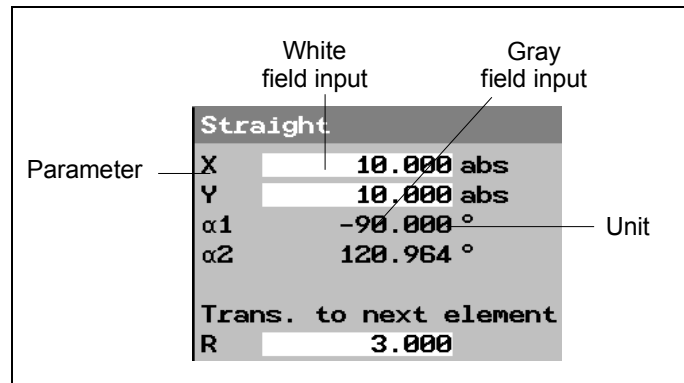

Parameter screen

Select parameters

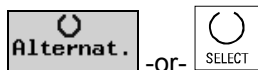

With some parameters the input field will offer you several options to select from. In these fields you cannot enter any data.

- Keep pressing the "Alternative" soft key or the "Select" key until the desired setting is displayed.

The "Alternative" soft key is only visible if the cursor is positioned on an input field with more than one option. Similarly, the "Select" key is only effective if it is possible to make a selection.

Setting parameters



For the remaining parameters you need to enter a numerical value in the input field by using the keys on the operator panel.

- Enter the required value.
- Press the "Input" key to terminate your input.

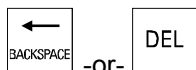

If you do not want to enter a value, i.e. not even value "0", press the "Backspace" or "Del" key.

Select a unit

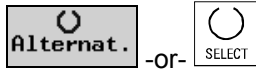

With some of these parameters, you can choose from different units.

- Keep pressing the "Alternative" soft key or the "Select" key until the desired unit is displayed.

The "Alternative" soft key is only visible if you can select from different units for this parameter. Similarly, the "Select" key is only effective if it is possible to make a selection.

Delete parameter

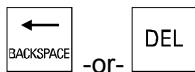

If one of the input fields contains an incorrect value, you can delete the entire value.

- Press the "Backspace" or "Del" key.

Edit/calculate parameter



If you do not want to overwrite the entire value in an input field, but only edit individual characters, change to insert mode. The pocket calculator is also active in this mode; you can use it to calculate parameter values during programming.

- Press the "Insert" key.

Insert mode and the pocket calculator are activated.

You can navigate within an input field by pressing the "Cursor left" and "Cursor right" keys.

You can delete individual characters by pressing the "Backspace" or "Del" key.

For more information about the pocket calculator, please refer to the section entitled "Pocket Calculator".

Accept parameters



If you have entered all the necessary parameters correctly in the parameter screen, you can exit the screen and save your settings.

- Press the "Accept" soft key or the "Cursor left" key.
If there are more than one input fields in a line and you want to accept the parameter with the "Cursor left" key, you must place the cursor in the input field on the far left.

You cannot accept parameters if these are incomplete or largely incorrect. The dialog line will then inform you which parameters are missing or faulty.

1.4 Fundamentals

1.4.1 Rectangular coordinate system

The principle of machining workpieces on a mill is based on a rectangular coordinate system consisting of three coordinate axes – X, Y and Z – which are parallel to the machine axes.

The orientation of the coordinate system in relation to the machine is dependent on the machine type. The axis directions are governed by the so-called "Right-hand rule" (according to DIN 66217).

Imagine you are standing in front of the machine with the middle finger on your right hand pointing in the infeed direction of the main spindle. The following then applies:

- Your thumb is then pointing in direction +X,
- your index finger in direction +Y and
- your middle finger in direction +Z.

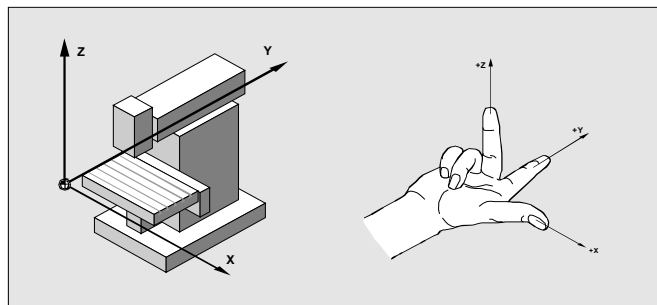

Machine coordinate system and "Right-hand rule"

1.4.2 Plane designations

Each plane is defined by two coordinate axes. The third coordinate axis (tool axis) in each case is perpendicular to this plane and determines the infeed direction of the tool (e.g. for $2\frac{1}{2}$ D milling operations).

When you program a workpiece, you must specify the plane in which you are working so that the control can calculate the tool offset values correctly. The plane is also significant for certain types of circle programming and for polar coordinates.

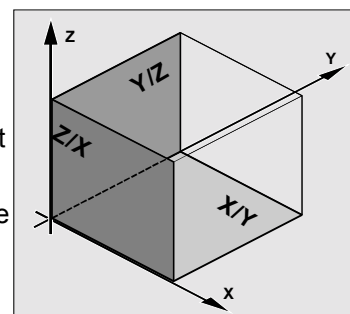

Working planes are defined as follows:

Plane	Tool axis
X/Y	Z
Z/X	Y
Y/Z	X

1.4.3 Polar coordinates

The rectangular coordinate system is suitable in cases where dimensions in the production drawing are orthogonal. For workpieces dimensioned with arcs or angles, it is better to define positions using polar coordinates. This is possible if you are programming a straight line or a circle (see Section "Program simple path motions").

Polar coordinates have their zero point in the "pole".

Example:

Using this system, points P1 and P2 could be defined as follows – in relation to the **pole** –:

P1 : Radius =100 plus angle =30°

P2 : Radius =60 plus angle =75°

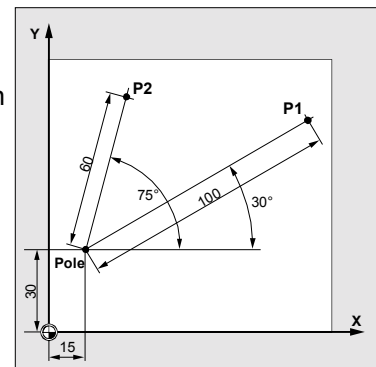

1.4.4 Absolute dimension

With an absolute dimension, all position data always refer to the currently valid zero point. With respect to tool motion, this means:

The absolute dimension describes the position to which the tool must move.

Example:

The positions for points P1 to P3 as absolute dimensions are as follows **in relation to the zero point**:

P1: X20 Y35

P2: X50 Y60

P3: X70 Y20

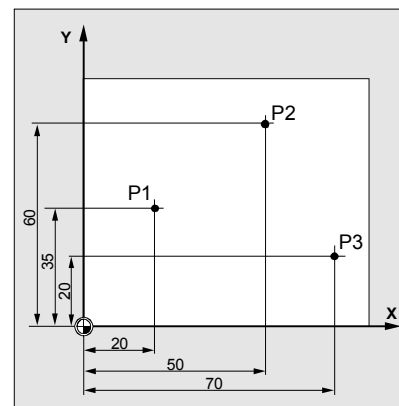

1.4.5 Incremental dimension

In the case of production drawings in which dimensions refer to some other point on the workpiece rather than the zero point, it is possible to enter an incremental dimension.

With an incremental dimension input, a position specification refers in each case to a point programmed beforehand.

Example:

The positions for points P1 to P3 as incremental dimensions are as follows:

P1: X20 Y35 ;(in relation to the zero point)

P2: X30 Y20 ;(in relation to P1)

P3: X20 Y-35 ;(in relation to P2)

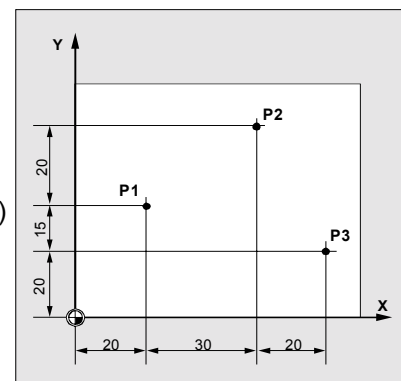

1.4.6 Pocket calculator function



Precondition



Function

The cursor is positioned on a parameter field.

Press the "Insert" key

or

Equal key

to activate **pocket calculator mode**.

To perform an arithmetic function on two values, press this key and then enter the symbol for the relevant function (+, -, *, /) followed by a value.

Then press the Input key and the second value to perform the calculation.

Example application:

A tool wear value in length L of

+ 0.1 must be included in a tool calculation.

- Place the cursor in the appropriate parameter setting field,
- Press the Equals key to open the parameter field and
- Add the new wear value to the existing value,
e.g. $0.5 + 0.1$
- Terminate calculation by pressing the "Input" key.

Result: 0.6

1.4.7 Inch/metric dimension system switchover



Function

This function enables you to switch between the metric and inch dimension systems depending on the dimension units used in your production drawing.

Every dimension system switchover applies to the entire machine, i.e. all relevant measurement data are automatically converted to the new dimension system, e.g.

- Positions
- Tool offsets
- Work offsets



Operating sequence

In "Machine Manual" operating mode change to the expanded horizontal soft key bar.

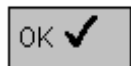
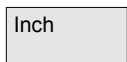
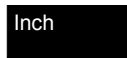

Press soft keys "ShopM. Settings" and "Inch"

- Switch from metric to **inches**: Soft key is active
- Switch from inches to **metric**: Soft key is not active

When you press the "Inch" soft key, a prompt box appears asking you to confirm the switchover operation.

The dimension system is adjusted correspondingly when you confirm with the "OK" soft key.

1.4.8 Switchover between machine and workpiece coordinate systems

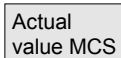
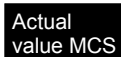

Function

The machine coordinate system (MCS) is the original system of your machine. In contrast to the workpiece coordinate system (WCS), it does not allow for tool offsets, work offset, scalings, etc.

Operating sequence

You can switch between the machine and workpiece coordinate systems by following the sequence below:

Press the "WCS MCS" key on the machine control panel.

or

Select soft key "Actual value MCS" in "Machine Manual" or "Machine Auto" operating mode.

- Switch from WCS (work) to **MCS (machine)**: Soft key is active.
- Switch from MCS (work) to **WCS (machine)**: Soft key is not active.

Notes

Operation

2.1	Power ON and reference point approach.....	2-51
2.1.1	User confirmation with Safety Integrated	2-54
2.2	Manual mode and settings for manual mode.....	2-55
2.2.1	Traverse the machine axes.....	2-55
2.2.2	Load tool from list into spindle.....	2-56
2.2.3	Enter a new tool in the list and load it to the spindle	2-57
2.2.4	Enter a new tool in the list and load it in the magazine	2-58
2.2.5	Start, stop and position the spindle manually.....	2-58
2.2.6	Machine-specific functions	2-60
2.2.7	Switch over machining plane/tool axis	2-60
2.2.8	Switch over to mm or inches	2-61
2.3	Set a new position value	2-62
2.4	Measure workpiece zero	2-64
2.4.1	Manual measurement	2-64
2.4.2	Automatic measurement.....	2-69
2.4.3	Calibrate electronic measuring tool.....	2-74
2.5	Measure tools.....	2-76
2.5.1	Measure tool manually	2-76
2.5.2	Measuring tools with a probe	2-78
2.5.3	Calibrate measuring probe.....	2-81
2.6	Machining in Manual mode	2-82
2.6.1	Change settings	2-82
2.6.2	Positioning.....	2-83
2.6.3	Face milling	2-83
2.7	MDI mode.....	2-85
2.8	Automatic mode	2-86
2.8.1	Switchover between "T, F, S", "G functions" and "Auxiliary functions" displays.....	2-87
2.8.2	Select a program for execution	2-88
2.8.3	Start/stop/abort program	2-89
2.8.4	Interrupt program	2-90
2.8.5	Start execution at specific program location	2-91
2.8.6	Program control.....	2-94
2.8.7	Program testing.....	2-95
2.8.8	Simultaneous recording before machining.....	2-96
2.8.9	Simultaneous recording during machining.....	2-97
2.9	Execute a trial program run.....	2-98
2.9.1	Single block.....	2-98
2.9.2	Basic block display.....	2-99
2.9.3	Correct program	2-100
2.10	Tools and tool offsets	2-101
2.10.1	Create a new tool	2-105

2.10.2	Create several cutting edges per tool.....	2-106
2.10.3	Change the tool name	2-107
2.10.4	Create a replacement tool	2-107
2.10.5	Manual tools	2-107
2.10.6	Tool offsets.....	2-108
2.10.7	Special tool functions.....	2-111
2.10.8	Create tool wear data	2-112
2.10.9	Tool monitoring.....	2-113
2.10.10	Magazine list.....	2-114
2.10.11	Delete a tool	2-115
2.10.12	Change the tool type	2-115
2.10.13	Load a tool.....	2-116
2.10.14	Unload a tool	2-117
2.10.15	Sort tools	2-118
2.11	Work offsets	2-119
2.11.1	Defining a work offset.....	2-121
2.11.2	Work offset list.....	2-122
2.11.3	Select/deselect work offset in the Manual area.....	2-124
2.12	Switching to CNC ISO operation	2-125
2.13	ShopMill Open (PCU 50).....	2-126
2.14	Remote diagnosis.....	2-126

2.1 Power ON and reference point approach

Switching control system ON and OFF



Switch ON

Function

A variety of methods can be employed to switch on the power supply to the control system or to the whole plant.

Please read the machine manufacturer's instructions.

After power ON, the main "Machine Manual" display appears on the screen

MANUAL				G function	
Reset					
WCS	Position [mm]	T, F, S		Auxiliary function	
X	33.000	T	4	D1	↕Z
Y	22.000	F		0.000 20%	All G functions
Z	-117.860	S		0.000 120%	
				0.000 I	
				0% 100% 200%	
Act. val. Mach(MCS)					
T, S, M Set W0 Meas. workp. Meas. tool Position Face mill.					

Main "Machine Manual" display

Switch OFF

For details on how to switch off the power supply to the control system or the whole plant:

Please read the machine manufacturer's instructions.

Reference point approach



...



Function

The "Ref" function is used to synchronize the control system and machine after power ON.

Various reference point approach methods may be employed.

Please read the machine manufacturer's instructions.

- The reference point can be applied only with respect to machine axes. The actual value display after power ON does not coincide with the actual position of the axes.
- A reference point must be approached in cases where there is no absolute measuring system installed on the machine!

Caution

If the axes are not positioned safely, then you must reposition them accordingly.

When doing so, please pay careful attention to the axis motions directly on the machine!

Ignore the actual value display until the axes have been referenced!
Software limit switches are not operative!

Operating sequence

Operating mode "Machine Manual" is selected.

Select machine function "Ref Point" .

Select the axis that you wish to move and

then press the "-" or "+" key.

Your selected axis moves to the reference point. The direction or sequence is defined by the PLC program supplied by the machine manufacturer.

If you have pressed the wrong direction key, the input will not be accepted and the axis does not move.

The display now shows the reference point value.

No symbol is displayed for axes which are not yet referenced.



This symbol is displayed next to the axis when it has reached



...



the reference point.

You can stop the axis you have started before it reaches the reference point.

Select the axis that you wish to move and

then press the "-" or "+" key.

Your selected axis moves to the reference point.

Caution

The machine is synchronized with the control once the axes have been referenced. The actual value display is set to the reference point value. It shows the difference between the machine zero and the slide reference point. From this moment onwards, path limitations such as software limit switches are operative.

End the function via the machine control panel by selecting operating mode "Machine Auto" or "Machine Manual".

- You can reference all axes simultaneously (depending on the PLC program supplied by the machine tool manufacturer).
- The feedrate override is operative.

Further notes

The machine tool manufacturer may specify the sequence in which axes must be referenced.

Only when all axes with a defined reference point have reached this point will you be able to activate NC Start in "Machine Auto".

2.1.1 User confirmation with Safety Integrated



If you use Safety Integrated (SI) on your machine, you need to confirm during reference point approach that the displayed current position of an axis corresponds to the real position on the machine. This confirmation is necessary for the other Safety Integrated functions to operate.



The user can only confirm for an axis if the axis has been previously referenced.

The displayed axis position always refers to the machine coordinate system (Machine).

For more information about user confirmation, please refer to:

References: /FBSI/, Description of Functions SINUMERIK Safety Integrated



➤ Select "Machine Manual" mode.



➤ Press the "Ref Point" key on the machine control panel.

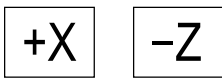

➤ Press an axis key.

Your selected axis moves to the reference point and stops. The reference point coordinate is displayed. The axis is highlighted with



➤ Press the "User Confirmation" soft key.

➤ Position the cursor on the desired axis.

➤ Confirm the machine position.

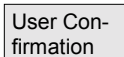

The axis status is now "safely referenced".

2.2 Manual mode and settings for manual mode

2.2.1 Traverse the machine axes



Function

You can perform the following tasks in Manual mode:

1. Synchronize the control system with the machine (reference point approach).
2. Set up the machine, i.e. activate manually controlled motions on the machine using the keys and handwheels provided on the machine control panel.
3. Activate manually controlled motions on the machine using the keys and handwheels provided on the machine control panel while a part program is interrupted.

Traverse axes by keys



Operating sequence

By pressing the increment keys, you can move the selected axis in defined increments in the appropriate direction every time you press an "Axis key" in manual mode.

The axes themselves traverse at the programmed setup feedrate.

Preset increments



- You can select preset increments by pressing keys [1], [10], ..., [10000]
- You can define variable increments via the "ShopM. Settings" menu in the extended horizontal soft key bar:

Select with soft key



Enter the increment of your choice in parameter "Variable increment".

Using the "Inc Var" key, move the selected axis by the preset increment with the "Axis key" in Manual mode.

Example: With an increment of 0.5mm, set a variable increment of 500.



Set setup feedrate

The "Setup feedrate" parameter is also entered in the "ShopMill Settings" menu. The setting in this parameter defines the feedrate (in mm/min) at which axes must traverse in setup mode.

A limitation for the maximum feed velocity is programmed in a machine data.

2.2 Manual mode and settings for manual mode

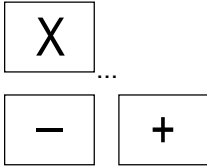

Select the axis that you wish to move and

then press the "-" or "+" key.

The feedrate and rapid traverse override switches may be operative.

Depending on the PLC program, you may be able to select more than one axis at a time.

Further notes

- After the control power supply has been switched on, it may be possible to move axes into the limit zone of the machine as they have not yet been referenced. They may trigger emergency limit switches in this zone.
- The software limit switches and working area limitation are not yet operative!
- The feed enable signal must be set.

Traverse axes by means of handwheels

Please note the machine manufacturer's instruction manual with regard to the selection and mode of operation of handwheels.

2.2.2 Load tool from list into spindle



Operating sequence

Press the "Jog" key and then soft key "T, S, M".

The cursor is positioned on the input field of tool parameter "T":



Call the tool list via the soft key

or
key

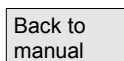

Select the tool of your choice in the tool list and

confirm your selection.



The tool is accepted.
You can select a cutting edge D.

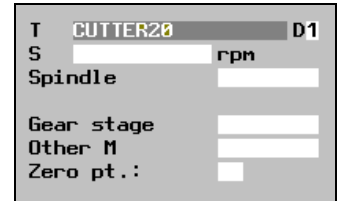

Upon confirmation with the "Cycle Start" key, the tool is inserted into the spindle.

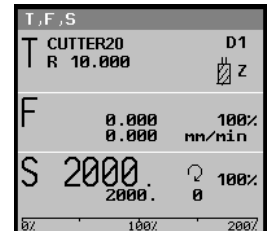

2.2.3 Enter a new tool in the list and load it to the spindle



Prepare for loading



Go into the "Machine Manual" area and select function "T, S, M".

The cursor is positioned on the input field of tool parameter "T":

Enter tool in tool list

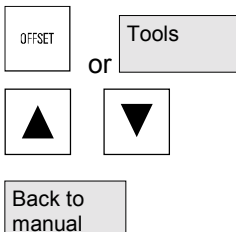

Call the tool list by selecting key "Offset" or soft key "Tools".

Select a free tool in the tool list and enter a new tool (as described in Section "Tools and tool offsets").

Select the "Back to manual" soft key to return automatically to the "T,S,M,..." function. The tool name is now entered in the input field of tool parameter "T".

Execute tool change operation



The tool change is enabled when you press "Cycle Start".

The loaded tool is marked by a spindle symbol in the tool list.

Now load the tool manually into the spindle as described in the machine manufacturer's instruction manual.

2.2.4 Enter a new tool in the list and load it in the magazine



Operating sequence

Enter tool in tool list



Call the tool list by selecting the "Offset" key



or select soft key "Tools WOs".



Select a free slot in the tool list and enter a new tool (as described in Section "Tools and tool offsets").

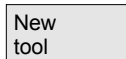

Select soft key "New tool".



Select the tool type of your choice and enter a tool name. Enter the tool offsets if applicable.

Load tool to magazine

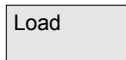

If the magazine on your machine has variable location assignment, execute the "Load" function.



If it is a magazine with fixed location assignment, load the tool in the required magazine location as described in the machine manufacturer's instruction manual.

2.2.5 Start, stop and position the spindle manually



Operating sequence

Set the spindle speed



Select the menu "T, S, M" in the "Machine Manual" operating mode.



Enter the speed setting of your choice in the spindle speed input field.

Press the "Cycle Start" key.

If the spindle is already rotating, it will accelerate/decelerate to the new speed setting. If the spindle is stationary, the value is stored as the setpoint speed. The spindle remains stationary.

Start/stop spindle

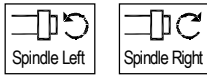

Alternative method



Position spindle



Change the spindle speed

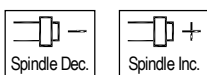
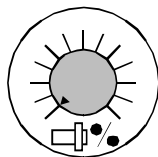

The "Spindle Left" or "Spindle Right" keys start the spindle rotating at the preset spindle speed and the currently valid spindle override weighting.

You can stop the spindle again by pressing the "Spindle Stop" key.

You can also select Start/Stop Spindle in the "Spindle" selection field in menu "T, S, M".

Clockwise spindle rotation:

CCW spindle rotation:

Spindle Stop:

and then execute by pressing "Cycle Start".

You can use this function to position the spindle at a specific angle, e.g. during a tool change.

- A stationary spindle is positioned via the shortest possible route.
- A rotating spindle is positioned as it continues to turn in the same direction.

Spindle positions are specified in degrees.

Select the menu "T, S, M" in the "Machine Manual" operating mode.

Select the symbol for spindle position in the "Spindle" selection field. The "Stop Pos." input field is displayed in which you must enter a spindle stop position.

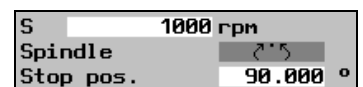

The spindle is turned to the selected position when you press "Cycle Start".

The spindle override switch can be used to set spindle speed **S** to between 50 and 120% of the last speed setting.

Or you can use the following keys on the OP032S operator panel:

You can reduce or increase programmed spindle speed "S" (corresponds to 100%) using the "Spindle Dec." or "Spindle Inc." keys.

100%

Press key "100%" if you wish to set the programmed spindle speed.

2.2.6 Machine-specific functions



Function

Gear stage



If your machine has a gear unit for the spindle, you can set the gear stage in selection field "Gear stage" in menu "T, S, M" and then activate it by pressing "Cycle Start".

Other special functions

The machine manufacturer determines which additional special functions are available for your use.

Please read the machine manufacturer's instructions.

2.2.7 Switch over machining plane/tool axis



Function

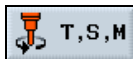

If your machine has a swivel-mounted work spindle, you can select the machining plane in the "Tool axis" selection field in menu "T, S, M".

This parameter is relevant for all screenforms in the Manual area, i.e. it influences the parameter displays for face milling or measurements. In addition, the plane setting determines how tool offsets are calculated in workpiece and tool measurements.

For instructions on how to swivel the spindle, please refer to information supplied by the machine manufacturer.

2.2.8 Switch over to mm or inches



Function

The selected unit of measurement affects the actual value display and distance-defining parameters.

You can switch over between mm and inches in the "Unit of measurement" selection field in menu "T, S, M" in the "Machine Manual" operating mode

and then activate it by pressing "Cycle Start".

The setting applies to the Manual area and remains valid until you switch to the other unit. In Automatic mode, the unit of measurement displayed in the program header is always activated.

Tool offsets and work offsets remain in the original basic system in which the system is set.

2.3 Set a new position value



Function

You can use the "Set work offset" function to enter a new position value for each individual axis in the actual value display.

The difference between the position value in the machine coordinate system **Machine** and the new position value in the workpiece coordinate system **Work** is saved in the currently active work offset or, if none is selected, in the basic offset. When the values in the active work offset are saved, they are stored in the coarse offset and the existing values in the fine offset are deleted.

The currently active work offset for the respective axis is displayed below the axis position window.

Operating sequence

Move the machine axes to the desired position (e.g. workpiece surface).

Select the "Set WO" menu in operating mode "Machine Manual".

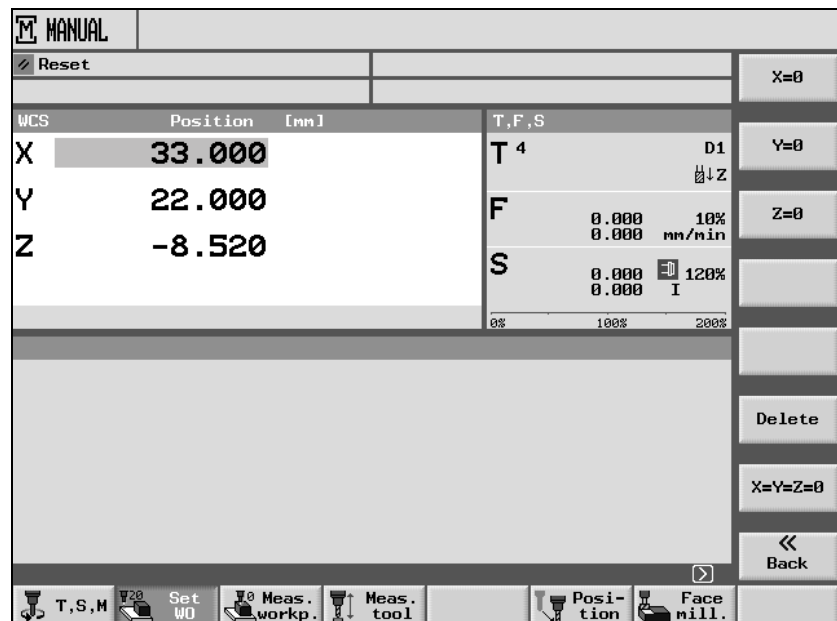

Basic offset menu

Set position value

You can enter new position values in the following ways:

- Directly via the input keypad.
Increase/decrease value via cursor keys. Terminate the input by pressing the "Input" key.

Reset offset

Select with soft key

A rectangular button with a thin black border and the word "Delete" centered inside in a simple sans-serif font.

- Via soft keys if you want to set position values to 0.

The offset is reset again when you select the "Delete" soft key.

The work offsets (WO1 etc.) are based on the basic offset.



2.4 Measure workpiece zero



The workpiece zero is always used as the reference point when programming a workpiece. You determine the workpiece zero either manually or automatically, depending on the tool.



The workpiece zero is saved in a work offset, i.e. the values are stored in the coarse offset and the existing values in the fine offset are deleted.

When you measure the zero point manually, you need to traverse your tool manually to the workpiece. You can either use edge probes, sensing probes or dial gauges with known radii and lengths. You can also use any other tool of which you know the radius and length. These tools must always be specified as edge probe type in the tool management.

With automatic measuring, you must first reposition the tool manually, then the tool is automatically traversed to the workpiece. You may only use electronic sensing probes and you must calibrate them first. These tools must always be specified as 3D probe in the tool management.

2.4.1 Manual measurement



With manual measurement, you can choose whether to traverse the tool to an edge or a corner of the workpiece. If you decide to use a corner as the workpiece reference point, you can also account for a rotation of the workpiece with regard to the machine table.

In addition, you can determine the center point of a hole or spigot as the zero point, e.g. for remachining.

The Z coordinate of the zero point is always determined via "Measure Edge".



Measuring edge

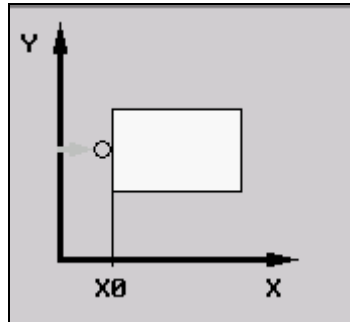
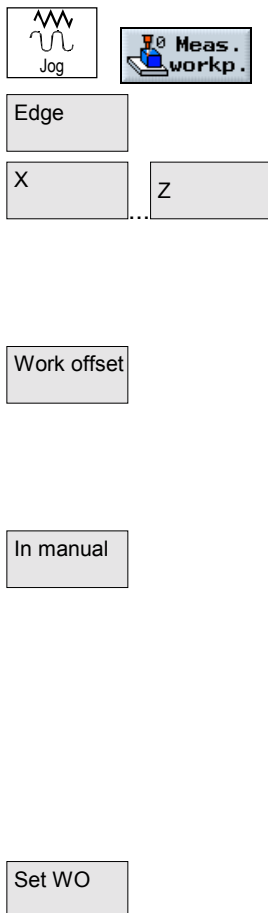

- Insert an edge probe type tool in the spindle.
 - Traverse the tool to near the workpiece edge you want to determine first.
 - In "Machine Manual" mode, select the "Meas. workp." softkey.
 - Press soft key "Edge".
 - Use the soft keys to select in which axis direction you want to approach the workpiece first.
 - Select the desired offset where you want to save the zero position.
- or-
- Press soft key "Work offset".
- and-
- Position the cursor on the desired work offset.
- and-
- Press soft key "In manual".
 - Select the direction (+ or -) you want to approach the workpiece in.
 - Specify the setpoint position of the workpiece edge you are approaching.
The setpoint position corresponds, e.g. to the dimension specifications of the workpiece edge from the workpiece drawing.
 - Traverse the tool to the workpiece edge.
 - Press soft key "Set WO".

The first coordinate of the workpiece zero - thus also the work offset - is calculated. The tool radius is automatically included in the calculation.

Example: Setpoint position workpiece edge $X_0 = -50$
 Approach direction +
 Tool radius = 3mm
 Work offset $X = 53$

- Repeat the process for the other two axes.

Measure corner

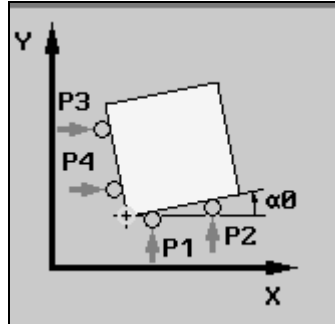

- Insert an edge probe type tool in the spindle.
- Traverse the tool to near the workpiece corner you want to measure.
- In "Machine Manual" mode, select the "Meas. workp." soft key.
- Press the "Corner" soft key.
- Select the desired offset where you want to save the zero position.
- or-
- Press soft key "Work offset".
- and-
- Position the cursor on the desired work offset.
- and-
- Press soft key "In manual".
- Select the position of the workpiece corner you want to measure.
- Specify setpoints X0 and Y0 of the workpiece corner you want to measure.
The setpoint position corresponds, e.g. to the dimension specifications of the workpiece corner from the workpiece drawing.
- Traverse the tool to the first measuring point P1.
- Press the "Save P1" soft key.
- Traverse the tool to the second measuring point P2.
- Press the "Save P2" soft key.
- Repeat this process for measuring points P3 and P4.
With an orthogonal workpiece you only need to approach 3 measuring points to determine its home position.



Corner



Work offset

In manual

Save P1

Save P2

Set position

- Press the "Set position" soft key.

The work offset and rotation α_0 are calculated. The tool radius is automatically included in the calculation.

Measure hole

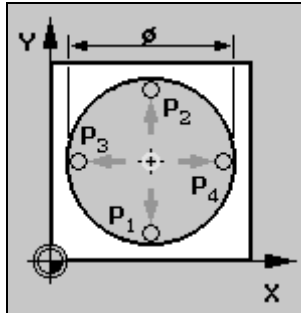

- Insert an edge probe type tool in the spindle.
- Move the tool into the hole.
- In "Machine Manual" mode, select the " Meas. workp." soft key.
- Press the "Hole" soft key.
- Select the desired offset where you want to save the zero position.

-or-

- Press soft key "Work offset".

-and-

- Position the cursor on the desired work offset.

-and-

- Press soft key "In manual".
- Specify setpoints X0 and Y0 of the hole center point.
- Traverse the tool to the first measuring point P1.
- Press the "Save P1" soft key.
- Traverse the tool to the second measuring point P2.
- Press the "Save P2" soft key.
- Repeat the process for measuring points P3 and P4.
- Press the "Set position" soft key.



Hole

Work offset

In manual

Save P1

Save P2

Set position

The hole diameter is calculated and the specified setpoint position is saved as the new zero point. The tool radius is automatically included in the calculation.

Measure spigot

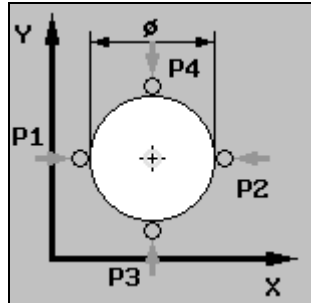

Jog

Meas.
workp.

Spigot

Work offset

In manual

Save P1

Save P2

Set position

- Insert an edge probe type tool in the spindle.
- Move the tool near the spigot.
- In "Machine Manual" mode, select the " Meas. workp." soft key.
- Press the "Spigot" soft key.
- Select the desired offset where you want to save the zero position.
- or-
- Press soft key "Work offset".
- and-
- Position the cursor on the desired work offset.
- and-
- Press soft key "In manual".
- Specify setpoints X0 and Y0 of the spigot center point.
- Traverse the tool to the first measuring point P1.
- Press the "Save P1" soft key.
- Traverse the tool to the second measuring point P2.
- Press the "Save P2" soft key.
- Repeat the process for measuring points P3 and P4.
- Press the "Set position" soft key.

The spigot diameter is calculated and the specified setpoint position is saved as the new zero point. The tool radius is automatically included in the calculation.

2.4.2 Automatic measurement



Measuring edge



Jog



Edge



X



Z

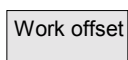

Work offset

With automatic measurement, you can choose whether to traverse the tool to an edge or a corner of the workpiece. If you decide to use a corner as the workpiece reference point, you can also account for a rotation of the workpiece with regard to the machine table.

In addition, you can determine the center point of a hole or spigot as the zero point, e.g. for remachining.

The Z coordinate of the zero point is always determined via "Measure Edge".

For automatic workpiece zero measurement, the machine manufacturer must have first set the parameters for measuring cycles.

Please read the machine manufacturer's instructions.

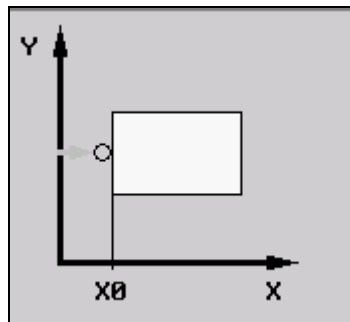

- Insert a 3D probe type tool in the spindle.
 - Traverse the tool to near the workpiece edge you want to determine first.
 - In "Machine Manual" mode, select the " Meas. workp." soft key.
 - Press soft key "Edge".
 - Use the soft keys to select in which axis direction you want to approach the workpiece first.
 - Select the desired offset where you want to save the zero position.
- or-
- Press soft key "Work offset".
- and-
- Position the cursor on the desired work offset.
- and-

In manual



- Press soft key "In manual".
- Select the direction (+ or -) you want to approach the workpiece in.
- Specify the setpoint position of the workpiece edge you are approaching.
The setpoint position corresponds, e.g. to the dimension specifications of the workpiece edge from the workpiece drawing.
- Press the "Cycle Start" soft key.

The automatic measuring process is started. Travel to the workpiece edge is initiated at the measuring feedrate specified via machine data; the return path back to the starting position is traveled in rapid traverse.

Please read the machine manufacturer's instructions.

Then the first coordinate of the workpiece zero - thus also the work offset - is calculated. The tool radius is automatically included in the calculation.

Example: Setpoint position workpiece edge $X_0 = -50$
 Approach direction +
 Tool radius = 3mm
 Work offset $X = 53$

- Repeat the process for the other two axes.

Measure corner

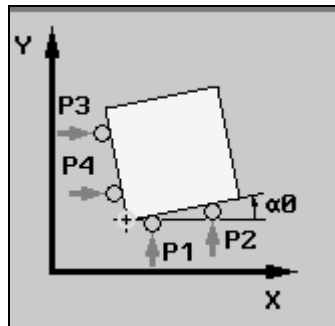

- Insert a 3D probe type tool in the spindle.
- Traverse the tool to near the workpiece corner you want to measure.
- In "Machine Manual" mode, select the " Meas. workp." soft key.
- Press the "Corner" soft key.
- Select the desired offset where you want to save the zero position.

-or-



Corner

Work offset

- Press soft key "Work offset".

-and-

- Position the cursor on the desired work offset.

-and-

In manual

- Press soft key "In manual".

- Select the position of the workpiece corner you want to measure.
- Specify setpoints X0 and Y0 of the workpiece corner you want to measure.

The setpoint position corresponds, e.g. to the dimension specifications of the workpiece corner from the workpiece drawing.

- Traverse the tool to near the first measuring point P1.

- Press the "Cycle Start" soft key.



The automatic measuring process is started. Travel to measuring point 1 is initiated at the measuring feedrate specified via machine data; the return path back to the starting position is traveled in rapid traverse.

Please read the machine manufacturer's instructions.

The position of measuring point P1 is saved.

- Traverse the tool to near the second measuring point P2.

- Press the "Cycle Start" soft key.

- Repeat this process for measuring points P3 and P4.
With a orthogonal workpiece you only need to approach 3 measuring points to determine its home position.



Set position

- Press the "Set position" soft key.

The work offset and rotation α_0 are calculated. The tool radius is automatically included in the calculation.

If you would like to achieve a greater accuracy, repeat the measuring process again. At the second measuring pass the angle α_0 calculated in the first measuring pass is taken into account when the measuring points are approached, so that the tool can now approach the measuring points at a right angle.



Measure hole

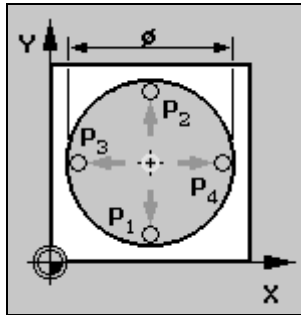

Hole

Work offset

In manual



- Insert a 3D probe type tool in the spindle.
 - Move the tool until it is positioned in the approximate center of the hole.
 - In "Machine Manual" mode, select the " Meas. workp." soft key.
 - Press the "Hole" soft key.
 - Select the desired offset where you want to save the zero position.
- or-
- Press soft key "Work offset".
- and-
- Position the cursor on the desired work offset.
- and-
- Press soft key "In manual".
 - Specify setpoints X0 and Y0 of the hole center point.
 - Enter the diameter of the hole.
This limits the area for rapid traverse. If you do not enter a diameter, the probe will approach the hole center point at measurement feedrate right from the starting point.
 - Press the "Cycle Start" soft key.

The tool automatically contacts 4 points in succession around the inside wall of the hole.

Then the specified setpoint position is saved as the new zero point.

The tool radius is automatically included in the calculation.

Measure spigot

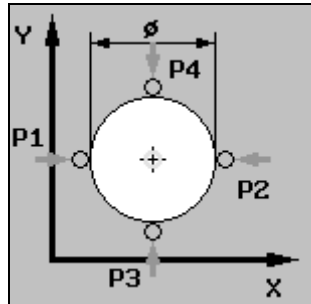

Spigot

Work offset

In manual



- Insert a 3D probe type tool in the spindle.
- Move the tool until it is positioned above the approximate center of the spigot.
- In "Machine Manual" mode, select the " Meas. workp." soft key.
- Press the "Spigot" soft key.
- Select the desired offset where you want to save the zero position.
- or-
- Press soft key "Work offset".
- and-
- Position the cursor on the desired work offset.
- and-
- Press soft key "In manual".
- Specify setpoints X0 and Y0 of the spigot center point.
- Enter the diameter of the spigot.
This limits the area for rapid traverse. If you do not enter a diameter, the probe will approach the hole center point at measurement feedrate right from the starting point.
- Specify the infeed depth DZ of the tool.
- Press the "Cycle Start" soft key.

The tool automatically contacts 4 points in succession around the outside wall of the spigot.

Then the specified setpoint position is saved as the new zero point.

The tool radius is automatically included in the calculation.

2.4.3 Calibrate electronic measuring tool



When the electronic measuring tools are loaded in the spindle, often clamping tolerance occurs. This can lead to measurement errors. In addition, you need to determine the trigger point of the measuring tool in relation to the spindle center (trigger point). Therefore, you need to calibrate the electronic measuring tool. The radius is calibrated in a hole, the length is calibrated on a surface. For the hole, you can use hole in the workpiece or use a ring gauge. The radius of the measuring tool must be contained in the tool list.



Calibrate radius

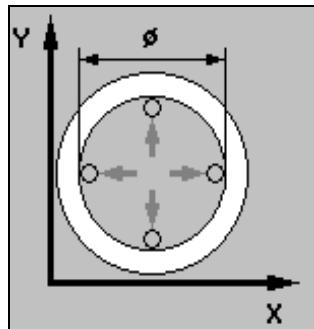

- Insert a 3D probe type tool in the spindle.
- Move the tool into the hole and position it in the approximate center of the hole.
- In "Machine Manual" mode, select the " Meas. workp." soft key.
- Press the "Calibration probe" and "Radius" soft keys.
- Enter the diameter of the hole.
- Press the "Cycle Start" soft key.



Calibration probe



Radius



The calibration process is initiated. First the exact hole center point is determined. Then the 4 trigger points on the inside wall of the hole are approached.

Calibrate length

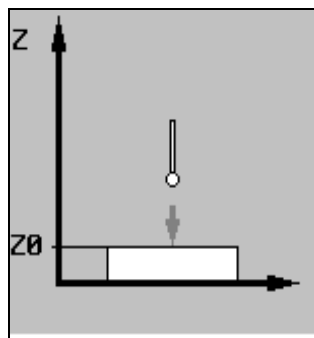

- Insert a 3D probe type tool in the spindle.
- Position the tool above the surface.

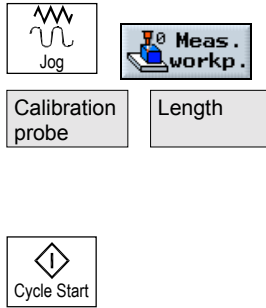

- In "Machine Manual" mode, select the " Meas. workp." soft key.
- Press the "Calibration probe" and "Length" soft keys.
- Specify reference point Z0 of the surface, e.g. of the workpiece or the machine table.
- Press the "Cycle Start" soft key.

The calibration process is initiated. The length of the measuring tool is calculated and entered in the tool list.

2.5 Measure tools



The various tool geometries must be considered when executing a program. These are stored as tool offset data in the tool list. Each time the tool is called, the control considers the tool offset data.

You can determine the tool offset data, i.e. the length and radius or diameter, either manually or automatically (per measuring probe).

2.5.1 Measure tool manually



When you measure manually, you traverse the tool manually to the workpiece. ShopMill uses the known position of the tool carrier reference point and the workpiece dimensions to calculate the tool length and the radius or diameter.



Depending on the setting in a machine data, you can measure the radius or the diameter of the tool.

Please read the machine manufacturer's instructions.



Measure length



Jog

Meas.
toolLength
manual >

Tools

In
manual

- In "Machine Manual" mode, select the "Measure tool" soft key.
- Press the "Length manual" soft key.
- Press the "Tools" soft key.
- Select the tool to be measured from the tool list.
- Press the "In manual" soft key.

The tool is entered in the "Length manual" display.

- Select the cutting edge number D and the duplo number DP for the tool.
- Approach the workpiece in the Z direction and perform scratching (see Section "Traversing the Machine Axes").

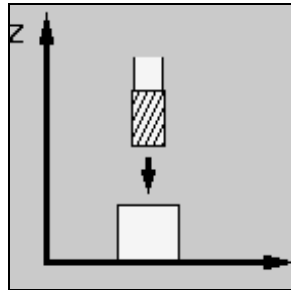

Measure tool length

Set
length

- Specify the setpoint position Z0 of the workpiece edge.
- Press the "Set length" soft key.

The tool length is calculated automatically and entered in the tool list.

If you do not want to use the workpiece to determine the tool length, but a test socket instead, no work offset may be selected or the basic work offset must be zero. The basic offset is also displayed in the parameter screen form to allow you to check the value.

Measure radius/diameter

Radius
manual >Dia.
manual >

Tools

In
manual

- In "Machine Manual" mode, select the "Measure tool" soft key.
- Press the "Radius manual" or "Dia. manual" soft key.
- Press the "Tools" soft key.
- Select the tool to be measured from the tool list.
- Press the "In manual" soft key.

The tool is entered in the "Radius/diameter manual" screenform.

- Select the cutting edge number D and the duplo number DP for the tool.
- Approach the workpiece in the X or Y direction and perform scratching (see Section "Traversing the machine axes").

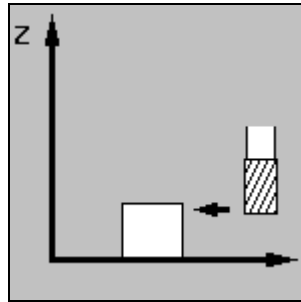

Measure radius/diameter

Set
radius

or

Set
diameter

- Specify the setpoint position X0 or Y0 of the workpiece edge.
- Press the soft key "Set radius" or "Set diameter".

The tool radius or diameter is calculated automatically and entered in the tool list.

2.5.2 Measuring tools with a probe



For automatic measurement, you determine the length and radius or diameter of the tool with the aid of a measuring probe (table probe system). ShopMill uses the known positions of the tool carrier reference point and measuring probe to calculate the tool offset data.



Before you measure a tool automatically, you must enter the approximate tool geometry data (length and radius or diameter) in the tool list and calibrate the probe.

Depending on the setting in a machine data, you can measure the radius or the diameter of the tool.

Please read the machine manufacturer's instructions.

When measuring, you can consider a lateral or longitudinal offset V . If the longest point of the tool is not located at the outside of the tool, or the widest point not at the base of the tool, you can store this difference in the offset.

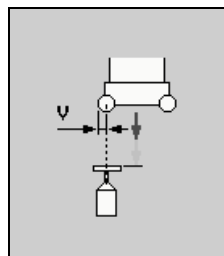

Lateral offset

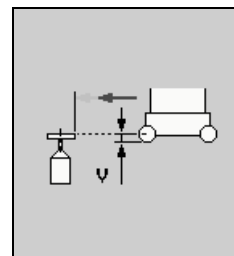

Longitudinal offset



Measure length

- Position the tool near the measuring probe so that it can be approached without collision.

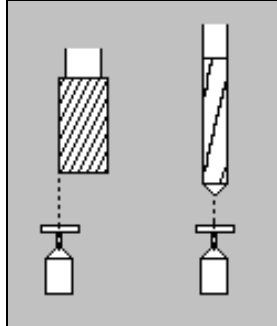

Measure tool length

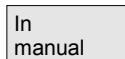
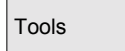
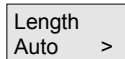

- In "Machine Manual" mode, select the "Measure tool" soft key.
- Press the "Length Auto" soft key.
- Press the "Tools" soft key.
- Select the tool to be measured from the tool list.
- Press soft key "In manual".

The tool is entered in the "Length Auto" screenform.

- Select the cutting edge number D and the duplo number DP for the tool.
- If necessary, enter the lateral offset V.
- Press the "Cycle Start" soft key.

The automatic measuring process is started. The tool length is calculated automatically and entered in the tool list.

The measuring process depends on the settings of the machine manufacturer.

Please read the machine manufacturer's instructions.

Measure radius/diameter

- Position the tool near the measuring probe so that it can be approached without collision.

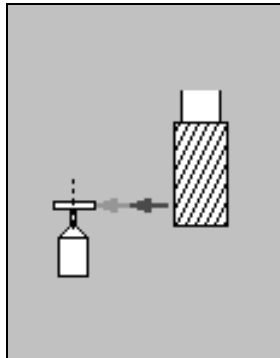

Measure radius/diameter

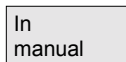
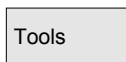
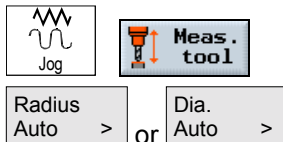

- In "Machine Manual" mode, select the "Measure tool" soft key.
- Then press the soft key "Radius Auto" or "Dia. Auto".
- Press the "Tools" soft key.
- Select the tool to be measured from the tool list.
- Press soft key "In manual".

The tool is entered in the "Radius/diameter Auto" screenform.

- Select the cutting edge number D and the duplo number DP for the tool.
- Enter the longitudinal offset V if necessary.
- Press the "Cycle Start" soft key.

The automatic measuring process is started. The tool radius or diameter is calculated automatically and entered in the tool list. The measuring process depends on settings made by the machine manufacturer.

Please read the machine manufacturer's instructions.

2.5.3 Calibrate measuring probe



Jog

Meas.
toolCalibrate
probe

Cycle Start

If you want to measure your tool automatically, you must first determine the position of the probe on the machine table with reference to the machine zero.

Mechanical probes are typically cube-shaped or cylindrical. Install the probe in the working area of the machine (on the machine table) and align it in relation to the machining axes.

You must use a miU-type calibration tool to calibrate the probe. You must enter the length and radius/diameter of the tool beforehand in the tool list.

- Move the calibration tool until it is positioned over the approximate center of the measuring surface of the probe.
- In "Machine Manual" mode, select the "Measure tool" soft key.
- Press the "Calibrate probe" soft key.
- Choose whether you want to calibrate the length or the length and the diameter.

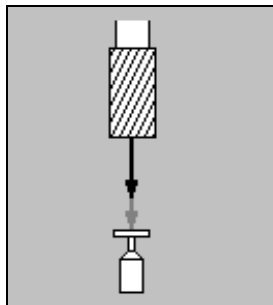

Calibrate length only

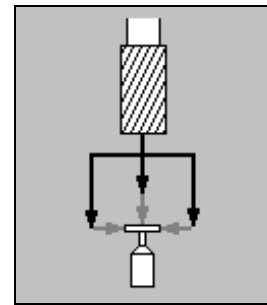

Calibrate length and diameter

- Press the "Cycle Start" key.

The calibration is automatically executed at the measuring feedrate. The current distance measurements between the machine zero and probe are calculated and stored in an internal data area.

2.6 Machining in Manual mode

2.6.1 Change settings



Select with soft key

Operating sequence

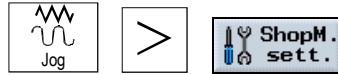

Default settings are entered in this menu for

- **Return plane**
The return plane is the position above the workpiece which is approached in rapid traverse during manual face milling.
- **Safety clearance**
The safety clearance is the distance between the tool tip and the workpiece surface. This position is approached in rapid traverse. The programmed cycle - face milling - is then executed at the programmed machining feedrate.
- **Setup feedrate**
The feedrate at which the axes are traversed in manual mode.
- **Variable increment size**
If in manual mode you want to traverse the axes using variable increment sizes instead of the predefined one, you can enter the required step size here.
Example application: If you want a step size of 500µm (= 0.5mm) specify 500.

These settings remain valid until you change them.

These settings are made for the programs in the program header.



2.6.2 Positioning



Select with soft keys

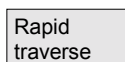

Operating sequence

In Manual mode, you can move the axes to certain positions for the purpose of performing simple machining operations.



Select the axis/axes that you wish to move and enter its/their target position/s. Enter your selected setting for feedrate **F**, e.g. 1000mm/min.

Feedrate	
X	abs
Y	50.000 abs
Z	abs
F	1000.000 mm/min

Alternatively, you can select this soft key to move the axes in rapid traverse.

The axes are moved to the specified target position when you press "Cycle Start".

2.6.3 Face milling



Select with soft keys



Function

You can use this cycle to face mill any workpiece. The cycle distinguishes between rough cutting (repeated end milling of surface with depth infeed inside workpiece) and finish cutting (single end mill operation on surface with retraction of mill and depth infeed outside workpiece).



Then select the desired direction of machining and enter parameter settings in input screenform.

Please also note instructions regarding face milling in Section "Programming – Face Milling".

Confirm your inputs with soft key "OK"

and go to the program view in the Manual area:

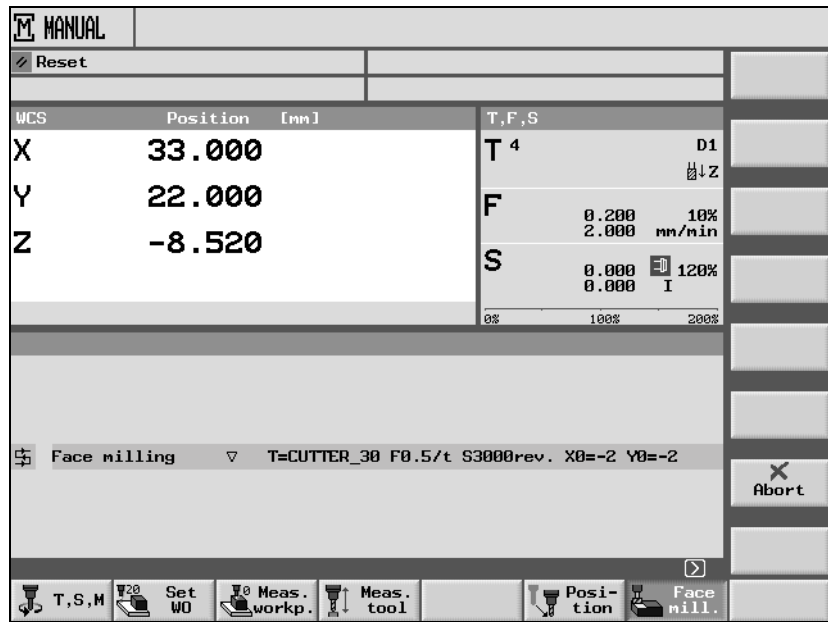

Example of face milling in the program view

Press the "Cycle Start" key to start the "Face milling" cycle.



2.7 MDI mode



Function

You can write and execute programs block by block in G code in "MDI" (Manual Data Input) mode. To do this, you enter specific movements as individual program blocks in the control via the keyboard.

The "MDI" program view displays position, feedrate, spindle and tool values as well as the contents of the MDI program.

WCS		Position [mm]	T, F, S		G function
X	33.000		T 4	D1	Auxiliary function
Y	22.000		F	0.000 10% 0.000 mm/min	All G functions
Z	-8.520		S	0.000 120% 0.000 I	
			0%	100%	200%
MDI					Delete MDI prog.
M3S3600					
M30					
==eof==					
					Act. val. Mach (MCS)

Example of a program in the "MDI" program view

Select with soft key



Enter the required G code.

Start program



The control executes the blocks you have entered when you press the "Cycle Start" key.

Delete program



Programs written in MDI mode are automatically deleted as soon as they have finished running. Alternatively, you can delete them by selecting soft key "Delete MDI program".

2.8 Automatic mode



Preconditions

In the "Machine Auto" operating mode, you can execute machining programs and monitor the progress of the current machining operation online on the screen.

The preconditions for executing machining programs are as follows:

- You have already synchronized the control measuring system with the machine (i.e. "approached" reference points).
- You have already written the relevant machining program.
- You have checked or entered the necessary offset values, e.g. work offsets and tool offsets.
- The required safety interlocks are already active.

M AUTO					
Reset		/_N_WKS_DIR/_N_SHOPMILL_WPD		G function	
		SHOPMILL			
WCS	Position [mm]	T, F, S			
X	33.000	T 4		D1	Auxiliary function
Y	22.000	F	0.000	10%	All G functions
Z	-8.520	S	0.000	120%	
			0.000	I	
			0%	100%	200%
P N5 SHOPMILL					
N10 Longit. slot ▾ T=12 F0.1/t S600rev. Z1=5inc W10 L22					
N15 001: Hole full cir. Z0=0 X0=70 Y0=70 R32 N6					
N20 Circ.slot ▾ T=FRAESER6 F300/min S400rev. X0=70 Y0=70					
N25 Circ. pocket ▾ T=14 F0.2/t S100rev. X0=70 Y0=70 Z0=0					
N30 Rectang.pocket ▾ T=FRAESER16 F0.2/t S400rev. X0=130					
END N35 Program end					
Infeed DXY too large					
		NC Prog. Cntrl.	NC Block search	Real-sin	Prog. corr.

Example of program view in "Machine Auto"

Programs produced with an earlier version of ShopMill can also be executed in the current version of ShopMill. If an older ShopMill program is executed once in the current ShopMill version, it is deemed to be a current ShopMill program version.

You can also execute a Version-6.3 ShopMill program in ShopMill 6.2, provided that you consider the following points:

- If the machining type "Edge finishing" is programmed for a longitudinal groove in ShopMill 6.3, the parameter is replaced by "Roughing" in ShopMill 6.2.
- The functions "Deep drilling" and "Cicumferential slot" programmed under ShopMill 6.3 only run in ShopMill 6.2 if you check the function parameters again in ShopMill 6.2 and confirm these.

When a ShopMill program with Version 6.3 is executed in ShopMill 6.2, it is deemed to be a Version-6.2 program.

2.8.1 Switchover between "T, F, S", "G functions" and "Auxiliary functions" displays



If while machining the workpiece you want to know e.g. whether the tool nose radius compensation is active or which unit of measurement is being used, activate G function display or auxiliary functions.



16 different G groups are displayed under "G function". Within a G group, only the G function that is currently active in the NC is displayed.

Alternatively, all G groups with all their associated G functions are displayed under "All G func.".

The auxiliary functions also include OEM M and H functions which pass parameters to the PLC and trigger the reactions defined by the machine manufacturer there.

Please read the machine manufacturer's instructions.

It is possible to display up to five M functions and three H functions.

When executing a ShopMill program, you can display the G functions currently active in the NC too, as the ShopMill functions are converted to G code internally.



G function

- Select the "G function" soft key in "Machine Manual" or "Machine Auto" operating mode.

The G functions that are currently active at program execution are displayed within a G group instead of parameters T, F and S. If you press the "G function" soft key again, status display "T, F, S" appears again.

-or-

All
G func.

- Press the "All G func." soft key.

Now all G groups and G functions are displayed instead of the T, F and S parameters. If you press the "All G func." soft key again, status display "T, F, S" appears again.

-or-

Auxiliary
function

- Press the "Auxiliary function" soft key.

The auxiliary functions that are currently active at program execution are displayed instead of parameters T, F and S. If you press the "Aux. func." soft key again, status display "T, F, S" appears again.

2.8.2 Select a program for execution

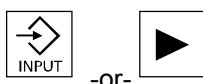
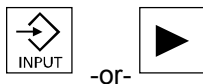
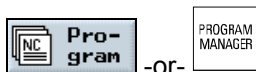
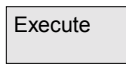
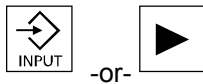
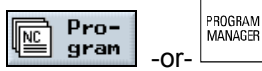

Operating sequence

- Press the "Program" key or "Program manager" soft key.

The directory overview is displayed.

- Position the cursor on the directory where you want to select a program.

- Press the "Input" or "Cursor right" key.

The program overview is displayed.

- Position the cursor on the program you want to execute.

- Press soft key "Execute".

ShopMill automatically changes to "Machine Auto" operating mode and uploads the program.

-or-

- Press the "Program" key or "Program manager" soft key.

The directory overview is displayed.

- Position the cursor on the directory where you want to select a program.

- Press the "Input" or "Cursor right" key.

The program overview is displayed.

- Position the cursor on the program you want to execute.

- Press the "Input" or "Cursor right" key.

The selected program is opened in the "Program" operating area. The machining plan is displayed.

- Position the cursor on the program block you want to start program execution from.

- Press soft key "Execute".

ShopMill automatically changes to "Machine Auto" manual mode, loads the program and conducts a block search until it reaches the selected program block (see Section "Enter a program at any selected point").

If you select a program for execution for the first time and it contains cycles "Stock removal against the contour" or "Contour pocket", the individual stock removal steps are calculated for the contour pocket. This process may take several seconds depending on the complexity of the contour.

2.8.3 Start/stop/abort program



Function

Shows how to start/stop programs that are loaded in "Machine Auto" operating mode and resume program execution after abnormal program termination.

If the program is loaded in "Machine Auto" operating mode, and "Automatic" is activated on the machine control panel, you can also start the program from any operating area and not in "Machine Auto" operating mode.

This start option must be activated in a machine data.

Please read the machine manufacturer's instructions.

Precondition

No alarms are currently active.
The program is selected.
The feedrate enable signal is set.
The spindle enable signal is set.



Operating sequence

Start machining



- Press the "Cycle Start" key.

The program is started and executed from the start or from the selected program block onwards.

Stop execution



- Press the "Cycle Stop" key.

Machining stops immediately, individual program blocks are not executed to the end. At the next start, execution is resumed at the same location where it stopped.

Stop execution



- Press the "Reset" key.

Execution of the program is aborted. At the next start, execution begins again from the start of the program.

Start execution from the operating area

The program is loaded in "Machine Auto" operating mode and "Automatic" operating mode is activated on the machine control panel.



- Press the "Start" key.

The program is started and is executed from the start. The interface of the previously selected operating area still remains visible.

2.8.4 Interrupt program

Retract from contour

After you have interrupted a program ("NC Stop") in Automatic mode (e.g. in order to take a measurement on the workpiece and correct the tool wear values or after tool breakage), you can retract the tool from the contour in "Machine Manual" mode. In such cases, ShopMill stores the coordinates of the interruption point and displays the differences in distance traveled by the axes in "Machine Manual" mode as a "Repos" (= Reposition) offset in the actual value window.

For details of how to traverse machine axes, please refer to Section "Traverse machine axes".



Reapproach contour

The "Repos" function repositions the tool on the workpiece contour after traversal of the machine axes during a program interruption in Automatic mode.

Operating sequence

Precondition

"Machine Manual" operating mode is selected.

The axes have been moved away from the point of interruption.

Selects the "Repos" machine function.



...



Select the axis that you wish to move and

then press the "-" or "+" key.

You will not be able to move the axis beyond the point of interruption. The feed override is operative.





Warning

The rapid traverse override key is active. Non-adjusted Repos offsets will be adjusted automatically with program feedrate and linear interpolation when you switch over to Automatic and press "NC Start".

2.8.5 Start execution at specific program location



If you only want to execute a specific program section on the machine, you do not have to start program execution right from the beginning; instead you can start at a specific program block or text.



If you want to start program execution from a specific text, ShopMill will search for it in the program.

After the start block or text is specified, ShopMill then calculates the exact starting point for program execution.

In ShopMill cycles, the calculation is always carried out on the end point of the block. When calculating the starting point of all other ShopMill blocks and G code blocks, you can choose between four options.

1. Calculation **to contour:**

During a block search, ShopMill makes the same calculations as when executing a program. The program is executed from the beginning of the target block in an identical manner to normal program execution.

2. Calculation **to end point:**

During a block search, ShopMill makes the same calculations as when executing a program. The program is executed from the end of the target block or from the next programmed position of the target block.

3. **Without calculation**

ShopMill performs no calculations during block search, i.e. the calculation is skipped up to the target block. The internal control values are set to the same values as prior to the block search. This option is only available for programs that consist of G code blocks only.

4. **External - without calculation**

This variant is the same as for calculation at end point. However, subroutines that are called via EXTCALL are skipped during calculation. Similarly, the calculation is skipped up to the target block for G code programs that are executed fully via external drives (floppy disk/network drive).

This accelerates the calculation.

Notice

Modal functions not included in the calculated program section are not considered for the program section to be executed. This means that you should select a target block for the variants "Without calculation" and "External – without calculation" from which point on all information required for machining is included.

**Select ShopMill cycle**

Start
search run

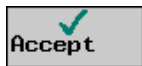

- Load a program in "Machine Auto" operating mode (see Section "Select a program for execution").
- Position the cursor on the desired target block.
- Press the "Block search" and "Start search run" soft keys.
- If you are using a program with chained program blocks and several technology blocks, select the desired technology block in the "Search" window.
This prompt does not appear with single program blocks.
- Press the "Accept" soft key.
- With chained program blocks, specify the number of the desired starting position.
This prompt does not appear with single program blocks.
- Press the "Accept" soft key.
- Press the "Start" key.

ShopMill carries out all necessary default settings.

- Press the "Cycle Start" key again.

The new starting position is approached. Then the workpiece is machined from the start of the target block.

You can cancel the search run by pressing the "Reset" key.

Select other ShopMill block or G code block

- Load a program in "Machine Auto" operating mode (see Section "Select a program for execution").
- Position the cursor on the desired target block.

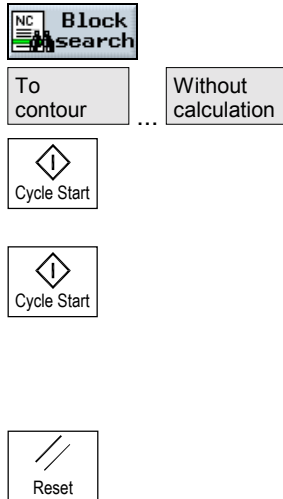

- Select soft key "Block search".
- Select a calculation option.
- Press the "Start" key.

ShopMill carries out all necessary default settings.

- Press the "Cycle Start" key again.

The new starting position is approached. Then the program is executed from the start or end of the target block, according to which calculation option is selected.

You can cancel the search run by pressing the "Reset" key.

Search text

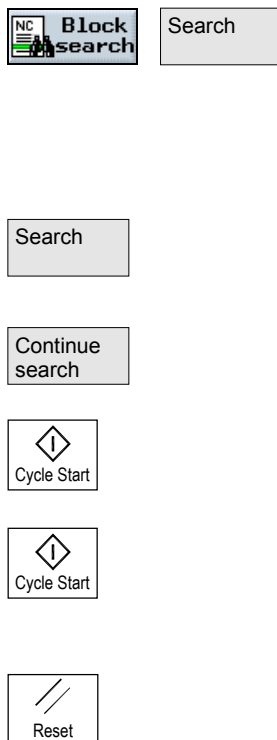

- Load a program in "Machine Auto" operating mode (see Section "Select a program for execution").
- Press the "Block search" and "Search" soft keys.
- Specify the text you want to search for.
- Select whether to start the search at the beginning of the program or from the current cursor position.
- Select soft key "Search".

The program block where the searched text occurs is highlighted.

- Press the "Continue search" soft key if you want to continue the search.
- Press the "Start" key.

ShopMill carries out all necessary default settings.

- Press the "Cycle Start" key again.

The new starting position is approached. The workpiece is then machined from this target block onwards.

You can cancel the search run by pressing the "Reset" key.

2.8.6 Program control



If you want to check the result while machining a workpiece, you can stop the machining process at locations that are specially designed for stopping (programmed stop).

If, however, you do not want to execute specific machining steps programmed with G code at every program pass, select these blocks separately (skip G code blocks). This is not possible with ShopMill blocks.



Programmed stop

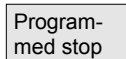
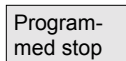

- Load a program in "Machine Auto" operating mode (see Section "Select a program for execution").
- Press the soft key "Prog. cntrl".
- Press the "Programmed stop" soft key.
- Press the "Start" key.

Execution of the program is started. The program run stops at every block for which "programmed stop" was defined (see Section "Miscellaneous Functions").

- Press the "Cycle Start" key again every time.

Program execution is resumed.

- Press the "Programmed stop" soft key if you want to execute the program without programmed stop. (The soft key is deselected again.)

Skip G code blocks

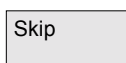
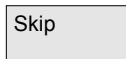

- Load a program in "Machine Auto" operating mode (see Section "Select a program for execution").
- Press the soft key "Prog. cntrl".
- Press the "Skip" soft key.
- Press the "Start" key.

Execution of the program is started. G code blocks that start with a "/" (slash) character preceding the block number are not executed.

- Press the "Skip" soft key again if the selected G code blocks are to be processed again the next time the program is executed. (The soft key is deselected again.)

2.8.7 Program testing



Program
test



Program
test

If you want to prevent any incorrect machining of the workpiece the first time the program is executed on the machine, you can test the program first without moving the machine axes.

ShopMill will then check the program for the following errors:

- Geometric incompatibilities
- Missing data
- Non-executable instruction sequences and jumps
- Violation of working area

ShopMill automatically detects syntax errors when it loads a program in "Machine Auto" operating mode.

Whether ShopMill executes auxiliary functions (M functions and H functions) of not during the program test depends on the settings made by the machine manufacturer.

Please read the machine manufacturer's instructions.

You can use the following functions for the program test:

- Stop execution with "programmed stop" (see Section "Control Program")
 - Graphic screen representation on screen (see Section "Simultaneous recording before machining").
- Load a program in "Machine Auto" operating mode (see Section "Select a program for execution").
 - Press the soft key "Prog. cntrl".
 - Press the "Program test" soft key.
 - Press the "Start" key.
- The program is tested without moving the machine axes.
- Press the "Program test" soft key again if you want to deactivate the test status after you have executed the program. (The soft key is deselected again.)

2.8.8 Simultaneous recording before machining



Status displays

Function

The "Program test" function offers you the option of graphically simulating a program run in Automatic mode before it is machined, i.e. without moving the machine axes.

Simultaneous recording is a software option.

The graphic displays a workpiece as if it were being machined with a cylindrical tool.

The status display in the graphic contains the following information:

- Current axis coordinates
- Block currently being processed.
- The processing time (in hours/minutes/seconds) indicates the approximate time that would actually be required to execute the machining program on the machine (incl. tool change). The timer is stopped if the program is interrupted.



Precondition



Program test

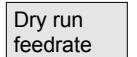

Operating sequence

The program is selected in "Machine Auto" mode.

Press the soft keys "Prog. cntrl" and "Program test".

If you select soft key "Dry run feedrate" as well, the programmed feed velocity is replaced by a dry run feedrate defined in a machine data.

Select soft key "Real-sim" and

start the program with "Cycle Start".

You can still use the program control functions such as "Cycle Stop", "Single block", "Feedrate override", etc.



Program view

When you press soft key "Program view", the display changes from the "Simultaneous recording" graphic to the program view in Automatic mode. The system continues to record graphic data as a background function.

You can return to the graphic display by pressing one of the following soft keys:

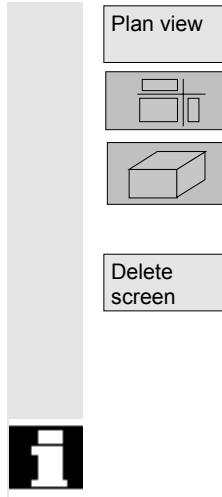

Plan view

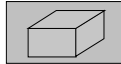
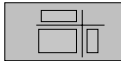
Delete
screen

- plan view,
- representation in 3 planes or
- 3D representation (volume model).

You can select soft key "Delete screen" to clear the machining operation graphic which has already been recorded while the program is executing. Recording of the machining operation will however continue.

For further information about the principles and operation, please refer to Section "Simulation".

2.8.9 Simultaneous recording during machining



Precondition



Function

You can track the current machining operation on the machine tool simultaneously by monitoring the graphic display on the control screen.

Simultaneous recording is a software option.

Operating sequence

Program test and dry run feedrate must not be selected.

Select soft key "Real-sim" and start the program with "Cycle Start".

The "simultaneous recording" function can be switched on at any time during machining.

An explanation of the functions available under "Simultaneous recording" can be found in Sections "Simultaneous recording before machining" and "Simulation".

2.9 Execute a trial program run

2.9.1 Single block



Function

When this function is active, the program is interrupted after every block which initiates some operation on the machine (these do not include arithmetic blocks).

The following defaults apply:

- A single block includes
- the whole machining operation in the case of drilling operations and the machining operations on one plane in the case of pocket milling.

Default setting

Select with soft key

Single
block fine

"Single block fine" active

When the "Single block fine" function is active, each individual drill infeed and pocket milling motion is executed as a separate block. Also, execution is stopped at the contour after every single contour element.

Select with soft key

Single
block fine

Single block via machine control panel



Activate the "Single block" key in "Machine Auto" mode. It will allow you to process a program block by block. The appropriate LED on the machine control panel lights up to indicate that single block mode is active.

If you have selected single block machining,

- the text "Stop: Block ended in single block" is displayed in the channel operating message line when the program is interrupted
- the current program block will not be executed until you press the "Cycle Start" key,
- the program stops automatically after a block has been processed,
- the following block will be processed when you press the "Cycle Start" key again.

Deselect single block mode



You can deselect the function by pressing the "Single block" key again.

2.9.2 Basic block display



Basic block



If you want to obtain further information about the axis positions and important G functions on insertion or during execution, you can show the basic display.

You can use the basic display both in test mode and during actual processing of the workpiece at the machine. All G code commands that initiate a function at the machine for the currently active program block are displayed in the "Basic block" window:

- Absolute axis positions
- G functions in the first G group
- Further modal G functions
- Further programmed addresses
- M functions

The "Basic block display" function must be set up by the machine manufacturer.

Please read the machine manufacturer's instructions.

- Load a program in "Machine Auto" operating mode (see Section "Select a program for execution").
- Select soft key "Basic block".
- Press the "Single Block" key if you want to execute the program blockwise.
- Start execution of the program is started.

The precise axis positions, G functions, etc. are displayed in the "Basic block" window for the currently active program block.

2.9.3 Correct program



Function

As soon as the control detects a syntax error in the program, it interrupts the program and displays the syntax error in the alarm line. In the event of such errors (program Stop status), you can correct the program in the program editor.



Operating sequence

Precondition

The program is selected in "Machine Auto" mode.
The program is in the Stop or Reset state.

Select with soft key



The program editor appears on the screen.



If an error has occurred, the errored block is marked. Press the "Input" key and then correct the block.



Press soft key "Accept" to transfer the correction to the current program.



After you have made the correction, you can continue processing by pressing this soft key and "Cycle Start".

- Cycle Stop status:
You can only modify blocks that have not yet been executed or read in by the NC.
- Reset status:
You can modify any block.



2.10 Tools and tool offsets

ShopMill offers you a tool management facility based on the following lists:

- Tool list
- Tool wear list
- Magazine list

Enter the tools and their offset data in the tool list or tool wear list. You will be able to identify in the magazine list which magazine locations are disabled or not.

Depending on individual requirements, a tool list might consist of the following:

- A tool change involving
 - a spindle or dual gripper
 - or a spindle with dual gripper
- at least one tool magazine
- and tools that are not assigned to any tool magazine.

For details of the functionality of your tool management system, please refer to the machine manufacturer's instruction manual.

The different lists can be adapted by the machine manufacturer if necessary.

Tool list

The tool list displays all tools and their offset data stored as a tool data block in the NC, irrespective of whether or not they are assigned to a magazine location. The tool list offers you all commonly used tools. You can assign geometric and technological tool data to tool types. Various different examples of each tool might exist to which you can assign the current offset data of the tool being used.

You can load and unload tools to and from a magazine via the tool list. When a tool is loaded, it is moved from its storage location to a magazine location. When it is unloaded, it is removed from the magazine and taken back to a storage location.

This loading and unloading of tool magazines is defined in a machine data.

OFFSET										
Tool list										
Loc	Typ	Tool name	DP	1st cutting edge		N	H	S	R	A
				Length	φ					
#		EDGE_TRACER	1	112.000	10.000					
1		DRILL_10	1	114.560	10.000	118.0			X	
2		CUTTER_8	1	106.980	8.000		2			
3		DRILL_15	1	119.251	15.000	118.0			X	
4		DRILL_20	1	116.067	20.000	118.0			X	
5		CUTTER_25	1	121.912	25.000		4		X	
6		CENTERDRILL	1	130.440	12.000	90.0				
7		CUTTER_20	1	118.462	20.000		3		X	
8		MILL_TAPER	1	124.354	12.000		2			
9		3D_PROBE	1	134.842	5.000					
10		DIEMILL_TAPER_10	1	120.062	10.000		2		X	
11		CUTTER_30	1	133.870	30.000		5			
12		DRILL_3	1	123.330	3.000	115.0				
13		CUTTER_35	1	142.560	35.000		4		X	

Example of a tool list with variable location assignment

The main display of the "Tools" operating area shows the current tool list with the following data:

Location

Location number

The following designations/symbols are used for:

- The spindle location
- The locations for gripper 1 and gripper 2 (applies only when a spindle with dual gripper is used)
- The magazine location numbers

If the configuration includes more than one magazine, the magazine number is specified first followed by the location number in the magazine:

e.g. 1/10 = Magazine 1 with location number 10

2/5 = Magazine 2 with location number 5

- Tools that are not assigned to a magazine in the tool list are stored in a location without location number.

This allows management of tools that are not actually contained in the tool magazine.

Type

Tool type

Depending on the tool type (represented by a symbol), only certain tool offset data are enabled.

Tool name

The tool is identified by means of its name. You can enter the name as text or a number (see Section "Change tool names").

DP

Duplo number of twin tool (replacement tool)

(D No.) cutting edge

Tool offset data length, diameter/radius and angle for the selected tool cutting edge.

The "H" column is displayed only for ISO dialect0-M programs. Every H number of an ISO dialect0-M program must be assigned to a tool offset data record.

N



Tool-spec. fct 1...4

Number of teeth on a mill
Spindle direction of rotation

Coolant supply 1 and 2 can be activated/deactivated (e.g. internal and external cooling)

Other tool-specific functions such as additional coolant supply, monitoring functions for speed, tool breakage, etc.

Please read the machine manufacturer's instructions.



The "Details" soft key displays the additional parameters "Rounding radius" or "Angle" for 3D tapered milling tools.

Tool wear list

You can adapt the tool geometry (length and radius/diameter) to the wear-induced geometry in the tool wear list.

You can also set the following monitoring functions for a tool.

- Monitoring of actual time of use (service life, number of workpieces)
- Monitoring of number of tool load operations
- Other tool status data (disable tool, tool in fixed location, oversized tool)

Tool magazine

The magazine locations with tools are specified in the magazine list. The list also indicates whether the magazine location is disabled (location disable) and the properties (tool status) assigned to the tools.

Fixed/variable location assignment

You can set a machine data to determine whether all tools must have a variable or fixed location assignment in the magazine.

If you select a variable location assignment, the tools are taken to the next available space in the magazine after a tool change. With a fixed location assignment, the tools are always taken back to the location assigned specifically to them.

Please refer to the machine manufacturer's instruction manual for details about location assignments in the tool magazine.

Graphical display of tools and magazine locations

In addition to the list of tools, you can also display the tools and magazine locations in a dynamic graphic display. The tools are displayed in the order in the list with the correct proportions. The graphical display must be set up by the machine manufacturer.

Please read the machine manufacturer's instructions.

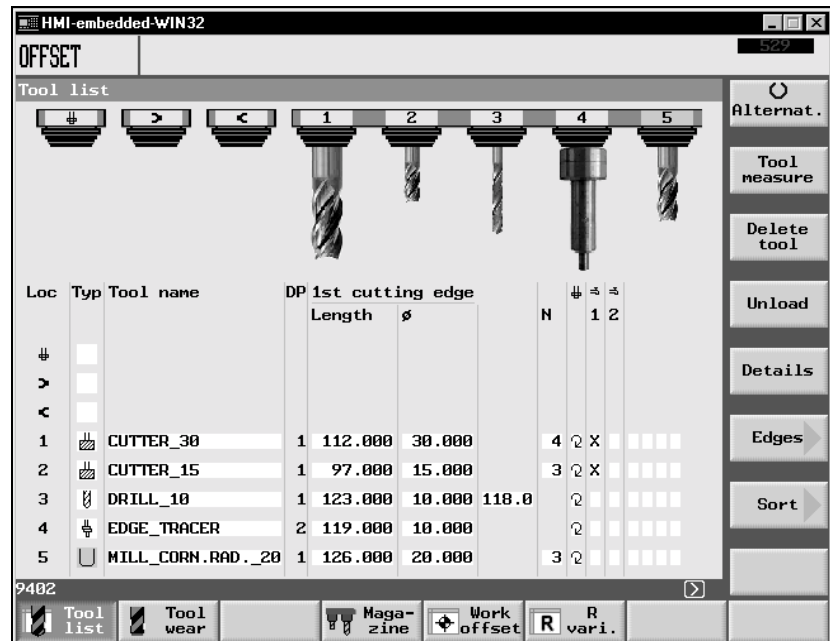

Graphical display of tools and magazine locations

The following applies for the graphical display:

- Small milling tools and 3-D tools are displayed as end mills, large ones as hobs.
- If a tool is too long for the display, the maximum possible length is shown.
- Oversized tools are truncated on the left and right sides.
- Tools that are not located in the magazine are displayed without toolholder.
- Disabled tools or magazine locations are marked as follows:



Disabled tool:



Disabled magazine location:

- The data of the relevant tool nose selected are used for the display.

If there is no tool nose for a tool in the selected view, the data of the first tool nose are used.

2.10.1 Create a new tool

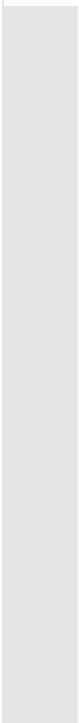

Function

You can enter tools and the associated compensation data directly into the tool list or simply read existing tool data outside the tool management (see Section "Backup/restore tool/zero data").

If you want to enter a new tool directly into the tool list, ShopMill offers a range of conventional tool types. The tool type determines which geometry data are required and how they will be calculated. The following common tool types are available:

	CUTTER
	DRILL
	CENTERDRILL
	DIEMILL_CYL
	BALL_END_MILL
	MILL_CORN_RAD.
	MILL_TAPER
	MILL_TAPER_CRAD
	DIEMILL_TAPER
	EDGE_FINDER
	3D_PROBE

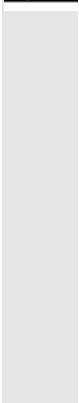

Select with soft keys



Cutter

... 3D tools

3D tools

Operating sequence

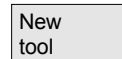

Use the cursor keys to select the tool location you want

and confirm your selected tool type with the soft key.

A new tool is then created.

In addition to the geometry data in the tool list, you must specify further parameters for 3D tools.

Type	Name	Additional parameter
110	Cylindrical die mill	-
111	Ball end mill	Rounding radius
121	End mill with corner rounding	Rounding radius
155	Bevel cutter mill	Angle for tapered tools
156	Tapered mill with corner rounding	Rounding radius, angle for tapered tools
157	Tapered die mill	Angle for tapered tools

Details

Press the "Details" soft key and enter the rounding radius or angle for tapered milling tools.

2.10.2 Create several cutting edges per tool



With tools with several cutting edges, each cutting edge is given its own correction data set. You can create up to 9 cutting edges for each tool.



You must specify an H number for ISO programs (e.g. ISO dialect 1). This corresponds to a particular tool offset block.



You create tools with multiple cutting edges in the tool list as described above and enter the compensation data for the 1st tool edge.

Cutting edges >

New cutting edge

➤ Then press soft keys "Cutting edges" and "New cutting edge".

Instead of the input fields for the 1st cutting edge, the compensation data input fields for the 2nd cutting edge are now displayed in the tool list.

➤ Enter the compensation data for the 2nd cutting edge.

➤ Repeat the procedure if you want to create more cutting edge compensation data.

➤ Press the "Delete cutting edge" soft key if you want to delete the cutting edge compensation data for a cutting edge.

You can only delete the data for the cutting edge with the highest tool edge number.

Delete cutting edge

D No. +

D No. -

With soft keys "D No. +" and "D No. -" you can display the compensation data for the cutting edge with the next higher/lower tool edge number.



2.10.3 Change the tool name



A newly created tool in the tool list is automatically assigned the name of the selected tool group. You may change this designation as you please to

- a tool name, e.g. "face_mill_120mm" or
- a tool number, e.g. "1" .

A tool name may contain a maximum of 17 characters. You can use any letters, digits, the underscore symbol "_", dots "." and slashes "/".

2.10.4 Create a replacement tool



A replacement tool is one that can be employed to perform the same machining operation as a tool that already exists (e.g. as a replacement after tool breakage).

When you create a tool as a replacement, you must give it the same name as an existing comparable tool.

Confirm the name with the "Input" key. The duplo number of the replacement tool will be incremented by 1 automatically.

The order in which replacement tools are inserted in the spindle is determined by duplo number **DP**.

2.10.5 Manual tools



Manual tools are tools which are needed during a machining operation but which exist only in the tool list and not in the tool magazine. Tools of this type have to be loaded and unloaded to and from the spindle by hand.

The "manual tool" function must be set up by the machine manufacturer.

Please read the machine manufacturer's instructions.

2.10.6 Tool offsets



Why do we need tool offsets?

Function

You do not have to take tool diameters and lengths into account when writing machining programs.

You can program workpiece dimensions directly, e.g. as specified in the production drawing.

When a workpiece is machined, the tool paths are controlled as a function of the relevant tool geometry in such a way that the programmed contour can be produced with any tool employed.

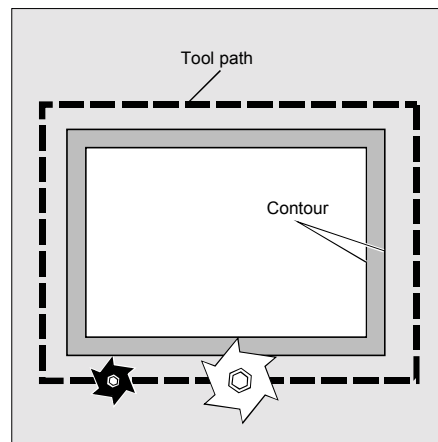

The control system corrects the traversing path

Enter the tool data separately in the "Tool list" and "Tool wear" tables.

When writing the program, you merely need to call the tool you require.

While the program is being processed, the control fetches the offset data it requires from the tool table and corrects the tool path individually for different tools.

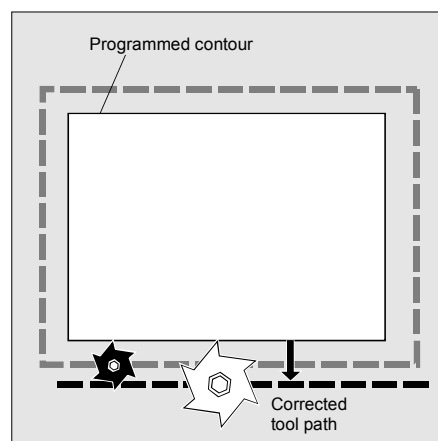

What type of tool offsets are available?

The offset memory of a tool includes the following:

- Tool type
The tool type determines which tool data are required and how they must be calculated (e.g. drill, centering tool, mill).
- Total size: Length, radius, angle (drill)
These comprise several components (geometry, wear). The control performs calculations on the components to obtain a final size (e.g. total length, total radius). The relevant total dimension becomes valid as soon as the offset memory is activated.

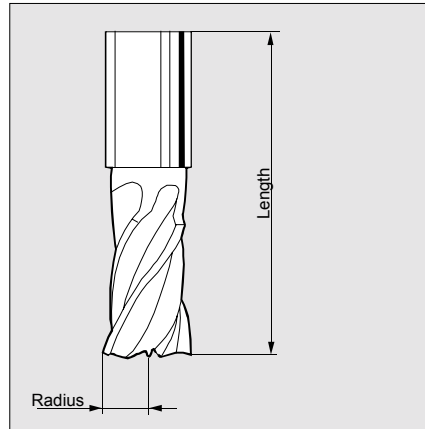

Tool length compensation

This value compensates the differences in length between the tools you use.

The tool length is interpreted to be the distance between the toolholder reference point and the tool tip. This measured length is entered in the tool list.

The control uses this measurement and the wear values to calculate travel movements in the infeed direction.

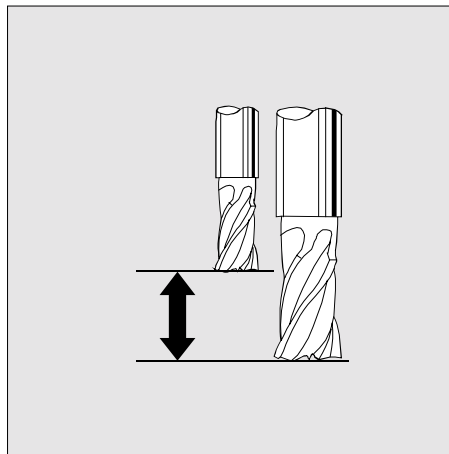

Tool radius compensation

"Contour" and "Tool path" are not identical. The mill or tool edge radius center point must travel along an equidistant to the contour. For this purpose, the programmed tool center point path is automatically displaced by the controller – as a function of radius and machining direction – in such a way that the tool edge travels exactly along the programmed contour.

The tool radius must be entered in the tool list. While a program is running, the control fetches the radii it requires and uses them to calculate the tool path.

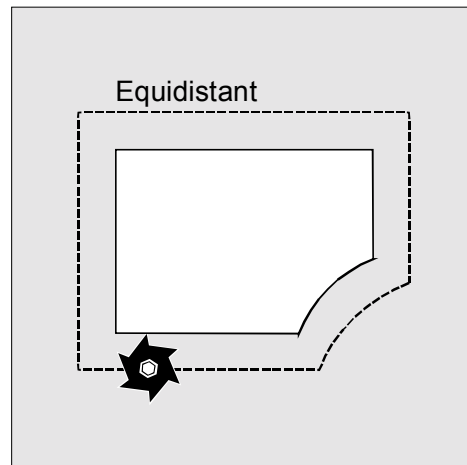

Offset values for milling tool (example)

Infeed	Geometry in plane
Z	Length in Z Radius in X/Y
Y	Length in Y Radius in Z/X
X	Length in X Radius in Y/Z

Offset values for drill (example)

Infeed	Geometry in plane
Z	Length in Z
Y	Length in Y
X	Length in X

Offset values are used in the simulation display and programming graphic for the following tools:

- Drill: Angle and radius/diameter
- Centering tool: Radius/diameter

2.10.7 Special tool functions



Number of teeth N

Function

You can assign other functions to tool types in the tool list.

Specify the number of teeth in this parameter. Parameter **N** is tool-dependent and can be applied only for milling tools. The control system calculates feedrate **F** internally if the feed is set in mm/tooth in the program.



Using the "Alternat." soft key, you can activate and deactivate the spindle direction of rotation (CCW/CW) in parameter "Spindle".

The spindle rotates in the clockwise direction of rotation.		Select with soft key
The spindle rotates in the counterclockwise direction of rotation.		
The spindle is stopped.		



Use parameters "coolant 1" and "coolant 2" if you want to supply coolant for the tool, e.g. for internal and external cooling.

Switch coolant ON: <input checked="" type="checkbox"/>	Select with soft key
Do not switch coolant ON: <input type="checkbox"/>	

Tool-specific functions

You can also assign another four machine-specific actions to a tool. You can activate or deactivate these functions using the "Alternat." soft key. Tool-specific functions might include, for example, a 3rd coolant supply or a tool breakage monitor.

Please read the machine manufacturer's instructions.

2.10.8 Create tool wear data

Select with soft key



The wear data for an existing tool must be entered in the tool wear list.

The following menu will appear on your screen:

OFFSET									
Tool wear								Prewarn. limit	
Loc	Typ	Tool name	DP	1st cutting edge	Δ Length	$\Delta\phi$	T	Prewarn. C	Tool If B
#	⊕	EDGE_TRACER	1	0.000	0.000				
1	⊕	DRILL_10	1	0.000	0.000				
2	⊕	CUTTER_8	1	0.000	0.000	T	25.0	30.0	B
3	⊕	DRILL_15	1	0.000	0.000				
4	⊕	DRILL_20	1	0.000	0.000				
5	⊕	CUTTER_25	1	0.000	0.000				
6	⊕	CENTERDRILL	1	0.000	0.000				
7	⊕	CUTTER_20	1	0.000	0.000				
8	⊕	MILL_TAPER	1	0.000	0.000				B
9	⊕	3D_PROBE	1	0.000	0.000				
10	⊕	DIEMILL_TAPER_10	1	0.000	0.000				
11	⊕	CUTTER_30	1	0.000	0.000				
12	⊕	DRILL_3	1	0.000	0.000				
13	⊕	CUTTER_35	1	0.000	0.000				

Example of a tool wear list with variable location assignment

Allowances for length and radii

In the tool wear list enter the delta values for length (Δ length) and radius (Δ radius) / diameter ($\Delta\phi$) for the tools.

Please note that

- a positive delta value signifies allowance (e.g. for subsequent finish cuts) and
- a negative delta value signifies undersize (tool wear)

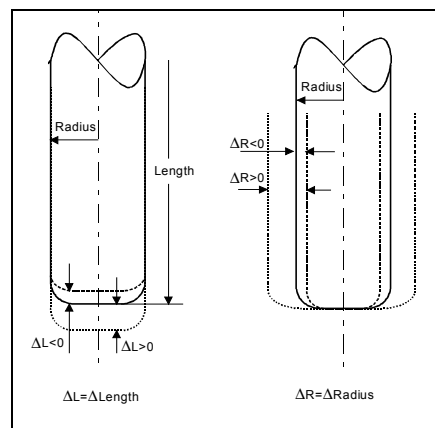

Allowances/undersizes for a corner radius mill

The correction values entered in tables "Tool list" and "Tool wear" become operative immediately a tool is called and inserted in the

spindle.

2.10.9 Tool monitoring



Select with soft key

You can assign the following tool monitoring functions and features to every tool in the tool wear list:

- Tool life
- No. of loadings
- Other tool properties
 - Disable tool
 - Tool in fixed location
 - Oversized tool

The tool monitoring functions are activated via a machine data.

Please read the machine manufacturer's instructions.



Tool life T

The tool life function monitors how long a tool is used with machining feed in minutes. If the remaining tool life is = 0, the tool is disabled. The tool can no longer be used at the next change. A replacement tool is inserted in its place, if one is available. Tool life monitoring always refers to the selected tool cutting edge.

No. of loadings C

The number of times that a tool may be loaded in the spindle to perform a machining operation must be entered in this parameter. If the number of spindle loading operations ("no. of loadings") has reached zero, the tool is disabled.

Prewarning limit

The prewarning limit is used for setting the tool life length or a maximum tool count when the first warning is issued.



You can activate the type of monitoring you want in parameter T/C after selecting the "Alternat." key. Enter the required setting in the appropriate input fields.

Other tool properties

You can assign the following additional properties to a tool:

- G: Disable tool, e.g. when the tool edge is worn.
- U: Tool oversized, i.e. half of each of the adjacent magazine locations (to left and right of location in question) is disabled.
- P: Tool at fixed location, i.e. the tool is permanently assigned to a particular magazine location (fixed-location-coded).



Select the function you require with the cursor keys and activate it with soft key "Alternat."

2.10.10 Magazine list

The magazine locations with tools are specified in the magazine list. The list also indicates whether the magazine location is disabled (location disable) and the properties (tool status) assigned to the tools.

Select with soft key



OFFSET						Alternat.
Magazine					Block magazine loc.	
Loc	Typ	Tool name	DP	Loc. disabl	Tool State	
#	⚙	EDGE_TRACER	1	<input type="checkbox"/>	■ ■ ■	
1	⚙	DRILL_10	1	<input type="checkbox"/>	■ ■ ■	
2	⚙	CUTTER_8	1	<input type="checkbox"/>	■ ■ ■	
3	⚙	DRILL_15	1	<input type="checkbox"/>	■ ■ ■	
4	⚙	DRILL_20	1	<input type="checkbox"/>	■ ■ ■	
5	⚙	CUTTER_25	1	<input type="checkbox"/>	■ ■ ■	
6	⚙	CENTERDRILL	1	<input type="checkbox"/>	■ ■ ■	
7	⚙	CUTTER_20	1	<input type="checkbox"/>	■ ■ ■	
8	⚙	MILL_TAPER	1	<input type="checkbox"/>	B ■ ■	
9	⚙	3D_PROBE	1	<input type="checkbox"/>	■ ■ ■	
10	⚙	DIEMILL_TAPER_10	1	<input type="checkbox"/>	■ ■ ■	
11	⚙	CUTTER_30	1	<input type="checkbox"/>	■ ■ ■	
12	⚙	DRILL_3	1	<input type="checkbox"/>	■ ■ ■	
13	⚙	CUTTER_35	1	<input type="checkbox"/>	■ ■ ■	

Example of magazine with variable assignment

Disable magazine location

Magazine locations can be reserved or disabled for specific tools, e.g. for oversized tools.



Select the magazine location you wish to disable.



Toggle with the "Alternat." soft key in the "Location disable" column until a "G" (= disabled) is displayed in the correct field. This location is now disabled. You will not be able to load any tool into this location.

Tool status

The "Tool status" column lists the properties which have been assigned to the currently active tool:

- G: Tool is disabled
- U: Tool is oversized
- P: Tool has a permanent location assignment

2.10.11 Delete a tool

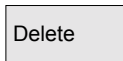
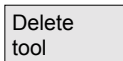

Function

Tools can be deleted in the tool list.

Operating sequence

Select the tool that you wish to delete.

Select the soft key "Delete tool" and confirm by selecting the "Delete" button. The tool data for the selected tool are deleted. The magazine location in which the tool was stored is enabled.

2.10.12 Change the tool type



Function

You can change a tool type into another tool type in the tool list.

Operating sequence

Select the tool that you wish to delete. The cursor is positioned on input field "Type".

Press the "Alternat." key to select the new tool type. The input fields for the new tool type are displayed.

2.10.13 Load a tool

**Function**

You can load a tool directly to the spindle or to another free location in the magazine from the tool list.

Operating sequence

Precondition

The machine data for tool management with loading/unloading is set.

Please read the machine manufacturer's instructions.

Select with soft key



or key



The "Tool list" menu is displayed on the screen.

Select the tool that you wish to delete.



Load

Select soft key "Load".

A window headed "Empty location" containing the number of the first free magazine location appears on the screen.

You can now enter a new location number

or

load the tool directly into the spindle.

Spindle

OK ✓

Starts the loading operation.

The tool is loaded to the specified magazine location.

Abort ✗

Aborts the loading operation.

2.10.14 Unload a tool



Precondition

Select with soft key

or key

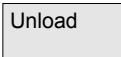

Function

When a tool is unloaded, it is removed from the magazine and entered in a store position in the tool list. The tool offset data block is not deleted. The unloaded tool has no location number in the store position.

Operating sequence

The machine data for tool management with loading/unloading is set.

Please read the machine manufacturer's instructions.



The "Tool list" menu is displayed on the screen.

Select a tool.

Select soft key "Unload".

The tool is removed from the magazine and taken back to a storage location.

2.10.15 Sort tools

**Function**

If you are working with large or multiple tool magazines, it may be helpful to display the tools sorted according to different criteria. This enables you to find tools faster in the lists.

Tools can be sorted in the tool list or tool wear list according to magazine assignment, tool name (alphabetic) or tool type. When they are sorted according to magazine assignment, empty magazine locations are displayed as well.

**Operating sequence**

Select with soft key

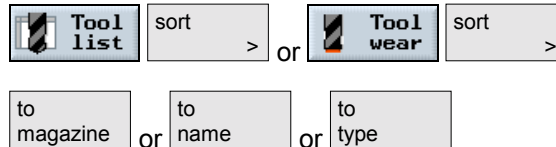

2.11 Work offsets



After referencing, the actual value display of the axis coordinate is based on the machine zero (M) of the machine coordinate system (Machine). Conversely, the program for machining the workpiece is based on the workpiece zero (W) of the workpiece coordinate system (Work).

The machine zero and workpiece zero do not have to be identical. The distance between the machine zero and workpiece zero may vary depending on the workpiece type and clamping method. This work offset is taken into account for program execution and can be composed of several different offsets.



The offsets are added together as follows:

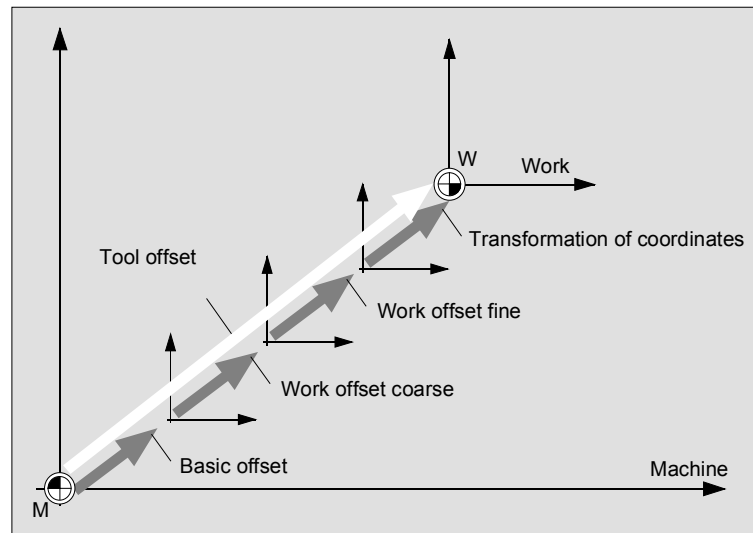

Work offsets

If the machine zero is not identical to the workpiece zero, there is at least one offset (basic offset or a work offset), where the position of the workpiece zero is saved.

Basic offset

The basic offset is a work offset that is always effective. If you have not defined a basic offset, then it is zero. You determine the basic offset via "Workpiece zero" (see Section "Measurement workpiece zero") or "Set work offset" (see Section "Set a new position value").

Work offsets

Work offsets (G54 to G57, G505 to G599) are made up of a coarse and a fine offset. You can call the work offsets from any ShopMill program (coarse and fine offsets are added together).

For example, you can save the workpiece zero in the coarse offset and then store the offset that results between the old and new workpiece zero when clamping a new workpiece.

The fine offsets must be set up by the machine manufacturer.

Please read the machine manufacturer's instructions.

How to define and call these work offsets is described in section "Defining work offsets" and "Calling work offsets".

Coordinate transformation

You always program coordinate transformations for a specific ShopMill program. They are defined by:

- Offset
- Rotation
- Scaling
- Mirroring

(see Section "Defining a coordinate transformation")

Total offset

The total offset is obtained from the sum of all offsets and coordinate transformations.

2.11.1 Defining a work offset



You enter work offsets (coarse and fine) directly in the work offset list.

The fine offsets must be set up by the machine manufacturer.
The number of possible work offsets is set in a machine data.

Please read the machine manufacturer's instructions.



- Press the soft key "Tools WOs" in the operating area "Work offset".

The work offset list is opened.

- Position the cursor on the coarse or fine offset you want to define.
- Specify the coordinate of your choice for each axis. Use the cursor keys to switch between axes.

-or-

- Press the soft key "Set X", "Set Y" or "Set Z" if you want to accept the position value of an axis from the position display for a coarse offset.

-or-

- Press the soft key "Set all" if you want to accept the position values of all axes from the position display for a coarse offset.

The new coarse offset is set. The values for the fine offset are incorporated and then deleted.

- Press the "Delete WO" soft key if you want to delete the values of the coarse and fine offsets simultaneously.

With the "Additional axes" soft key, you can display two additional rotary axes and determine their offset. These additional axes must be activated via machine data.

Please read the machine manufacturer's instructions.

Set X

Set Z

Set
all

Delete
WO

Additional
axes



2.11.2 Work offset list



The individual work offsets and the total offset are all displayed in the work offset list. The work offset that is currently active will have gray background highlighting. Further, the current axis positions in the machine coordinate system and the workpiece coordinate system are listed in the work offset list.



HMI-embedded-WIN32							
OFFSET							
WCS			MCS			Base (G500)	
X	100.000 mm		X1	200.000 mm		Work Measure	
Y	120.000 mm		Y1	-1678.000 mm			
Z	95.000 mm		Z1	295.000 mm			
	X	Y	Z	X Q	Y Q	Z Q	Clear Offset Position set X Position set Y Position set Z Position set all
Base	100.000	100.000	100.000	0.000	0.000	0.000	
WO 1	-170.000	-160.000	0.000	0.000	0.000	0.000	
	1.000	2.000	3.000				
WO 2	20.000	20.000	72.000	0.000	0.000	0.000	
	2.000	3.000	4.000				
WO 3	-79.426	619.339	-200.000	0.000	0.000	1.000	
	0.000	0.000	0.000				
Program Scale	0.000	0.000	0.000	0.000	0.000	0.000	
Mirror	1.000	1.000	1.000				
Total	100.000	100.000	100.000	0.000	0.000	0.000	

Work offset list

Basic offset

Base

The coordinates of the basic offset are displayed. You can change them here in the list.

Work offsets

WO1 ... WO3

The coordinates of the individual work offsets (1st line Coarse offset, 2nd line Fine offset) and the angle with which the coordinate system may be rotated about an axis if necessary, are listed. You can change this data here in the list (see Section "Defining work offsets"). The fine offsets must be set up by the machine manufacturer.

Please read the machine manufacturer's instructions.

You can display more work offsets by activating the "Page Down" key.



DRF

The handwheel offsets generated for each axis are displayed.

Coordinate transformation

Program

The active coordinate of the "Shift" transformation and the angle set in the "Rotation" transformation which the coordinate system rotates around are displayed.

You cannot change these values.

Scale

The active scale factor for the "Scaling" transformation is displayed for the relevant axis here.

You cannot change these values.

Mirror

The mirror axis which is defined via the "Mirroring" transformation is displayed.

You cannot change these settings here.

Total offset

Total

The total offset resulting from the basic offset and all active work offsets and coordinate transformations is displayed.



Additional axes

With the "Additional axes" soft key, you can display two additional rotary axes and determine their offset. These additional axes must be activated via machine data.

Please read the machine manufacturer's instructions.



Tools WOs

Work offset

- Press the softkey "Tools WOs" in the operating area "Work offset".

The work offset list is opened.

2.11.3 Select/deselect work offset in the Manual area



Select with soft key



Operating sequence

The following window is displayed.

Zero offset active			
T	CUTTER20	D1	Dimension: mm
S	1000 rpm		Tool axis: Z
Spindle		2	
Gear stage		I	
Other M			
Zero pt.:		1	

Select a work offset



Position the cursor on parameter "Work offset" and use soft key "Alternat." to set the work offset you require.

When you press the "Cycle Start" key, the work offset you have selected will be activated.

The active work offset is also displayed in the "WCS" window.
e.g. WO1

The offset values programmed in the "Work offset" menu are also taken into account in the tool coordinate system display **WCS** (work).

Deselect a work offset



Place the cursor on the "Work offset" parameter and set the field to "-" using the "Alternat." soft key.

When you press the "Cycle Start" key, the active work offset will be deactivated.

2.12 Switching to CNC ISO operation



You can switch from the ShopMill interface to the CNC ISO standard operator interface of the SINUMERIK 840D or 840D/840Di/810D system by pressing the "CNC ISO" soft key.

Soft key "CNC ISO" will work only if the machine manufacturer has implemented the function internally via the PLC interface.

Please read the machine manufacturer's instruction manual!

If the "CNC ISO" soft key is active, the following basic display of the CNC ISO operator interface appears on your screen:

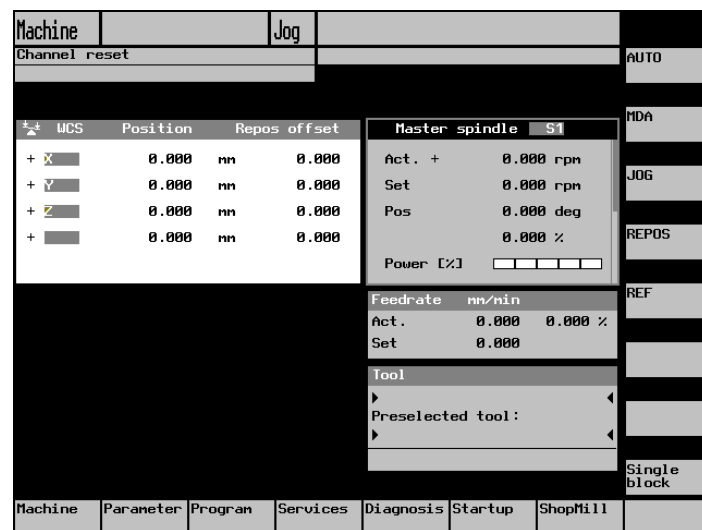

ShopMill



If you wish to return to the ShopMill operator interface, press soft key "ShopMill".

If you are working in the CNC ISO operator interface, please read the User Documentation for the SINUMERIK 840D/840Di/810D system (see Appendix, List of References).

2.13 ShopMill Open (PCU 50)



The ShopMill software is available for the PCU 50 in two versions, ShopMill Classic and ShopMill Open. ShopMill Classic is the new name for the conventional ShopMill software.



ShopMill Open differs from ShopMill Classic by its basic menu bar/expanded basic menu bar.

ShopMill Open does not offer the option to switch to the CNC ISO user interface. Instead, the HMI Advanced operating areas "Services", "Diagnosis", "Start-up" and "Parameters" (without tool management and work offsets), are located directly on the expanded horizontal soft key bar.

Machine	Program Manager	Program	Messages Alarms	Tools ZO					>
Services	Diagnosis	Start-Up	Parameters						

For a detailed description of the integrated HMI Advanced operating areas, please refer to:

References: /BAD/, Operator's Guide HMI Advanced
SINUMERIK 840D/840Di/810D

In addition, the machine manufacturer can assign other operating areas to some soft keys in the basic menu bar/expanded basic menu bar.

Please read the machine manufacturer's instructions.

2.14 Remote diagnosis



Remote diagnosis

Function

The control system can be operated from an external PC by means of a remote diagnostic function. You can use a modem to link the control system and the external PC.

The remote diagnostic function is activated on the CNC ISO operator interface in the Diagnosis operating area.

Remote Diagnosis is a software option.

For further information about remote diagnostics, please refer to:

References: /FB/, Description of Functions Extended Functions, F3

Programming with ShopMill

3.1	Fundamental programming principles.....	3-129
3.2	Program structure	3-132
3.3	Create a ShopMill program	3-133
3.3.1	Create new program; define a blank	3-133
3.3.2	Program new blocks.....	3-136
3.3.3	Change program blocks	3-138
3.3.4	Program editor	3-139
3.4	Program the tool, offset value and spindle speed	3-142
3.5	Contour milling	3-143
3.5.1	Free contour programming	3-144
3.5.2	Description of soft keys for free contour programming function	3-147
3.5.3	Description of parameters for line/circle contour elements	3-149
3.5.4	Programming examples for freely defined contours	3-150
3.5.5	Path milling of open and closed contours	3-153
3.5.6	Rough drilling in contour pockets	3-156
3.5.7	Machine (rough cut) pocket with islands	3-159
3.5.8	Remove residual material	3-160
3.5.9	Finish pocket with islands	3-162
3.6	Straight line or circular path motions	3-164
3.6.1	Line.....	3-165
3.6.2	Circle with known center point	3-167
3.6.3	Circle with known radius	3-168
3.6.4	Helix	3-169
3.6.5	Polar coordinates	3-170
3.6.6	Polar line	3-171
3.6.7	Polar circle	3-172
3.6.8	Programming examples for polar coordinates	3-173
3.7	Drilling	3-174
3.7.1	Centering.....	3-175
3.7.2	Drilling and reaming	3-176
3.7.3	Deep-hole drilling	3-177
3.7.4	Boring	3-179
3.7.5	Tapping	3-180
3.7.6	Thread cutting	3-181
3.7.7	Drill and thread milling.....	3-184
3.7.8	Position on freely programmable positions and position patterns.....	3-186
3.7.9	Freely programmable positions.....	3-187
3.7.10	Line position pattern	3-188
3.7.11	Matrix position pattern.....	3-189
3.7.12	Full circle position pattern	3-190
3.7.13	Pitch circle position pattern	3-192
3.7.14	Obstacle	3-193
3.7.15	Repeat positions	3-194

3.7.16	Programming examples for drilling.....	3-195
3.8	Milling	3-197
3.8.1	Face milling	3-197
3.8.2	Rectangular pocket	3-200
3.8.3	Circular pocket	3-204
3.8.4	Rectangular spigot.....	3-207
3.8.5	Circular spigot.....	3-209
3.8.6	Mill longitudinal slot	3-212
3.8.7	Circumferential slot.....	3-214
3.8.8	Use of position patterns for milling	3-216
3.9	Measurements.....	3-219
3.9.1	Measure workpiece zero	3-219
3.9.2	Measure tool.....	3-221
3.9.3	Calibrate the measuring probe	3-222
3.10	Miscellaneous functions	3-223
3.10.1	Call subroutine.....	3-223
3.10.2	Repeat program blocks	3-224
3.10.3	Change program settings	3-226
3.10.4	Call work offsets	3-227
3.10.5	Define coordinate transformation	3-228
3.10.6	Cylinder peripheral surface transformation	3-231
3.10.7	Swiveling	3-234
3.10.8	Miscellaneous functions	3-239
3.11	Insert G code in the ShopMill program.....	3-240

3.1 Fundamental programming principles

Important!

Please pay particular attention to the following fundamental principles when writing programs for your machine tool!

Axes

The 3 main axes on milling machines are designated as X, Y and Z. Axis Z is normally the tool axis.

Metric or inch unit of measurement

The control system can process both metric and inch dimensions. Depending on the basic setting you choose, the control interprets all geometric values as either metric or inch dimensions. Irrespective of the basic setting, you can set metric or inch dimensions in the program header (define blank). All dimensions stated in this section are metric.

Absolute dimensioning

With the absolute dimensioning method, dimensions refer to the zero point of the coordinate system of the total offset.

Incremental dimensioning

With the incremental dimensioning method, the programmed positional numerical value corresponds to the path to be traversed. The direction of travel is determined by the sign.

Tool T





A tool must be programmed for every cutting operation. With the ShopMill machining cycles, a tool selection is already integrated in every parameterization screenform. Exception: You must select a tool before programming simple straight lines and circles. Tool selection is modal with straight line/circle, i.e. if several machining steps with the same tool occur in succession, you only need to program the tool for the 1st straight line/circle.

Tool length compensation

Tool length compensations take effect immediately the tool is loaded into the spindle. Different tool offsets can be assigned to each tool with multiple cutting edges. The tool length compensation of the spindle tool remains active even after the program has been executed (RESET).

3.1 Fundamental programming principles

Tool radius compensation The tool radius compensation is automatically included in the cycles except for path milling. You can machine with or without radius compensation in conjunction with the "Path milling" and "Line" functions. In the case of the "Line" function, the tool radius compensation has a modal action, i.e. it is not automatically deactivated again.

-  Radius compensation left of contour
-  Radius compensation right of contour
-  Radius compensation off
-  Radius compensation is retained as set

Spindle speed

The spindle speed (S) determines the number of spindle rotations per minute. The CW/CCW setting is made in the tool list in ShopMill.

Programming:

The spindle speed is input when a new tool is loaded into the spindle. As an alternative to spindle speed, a cutting rate (V) can be specified in m/min.

Spindle start/spindle stop:

The spindle is started directly after a new tool has been loaded. It is stopped on Reset, end of program or tool change.

Cutting rate

Peripheral speed at which the tool cutting edge machines the workpiece. Cutting rates (V) are specified in m/min.

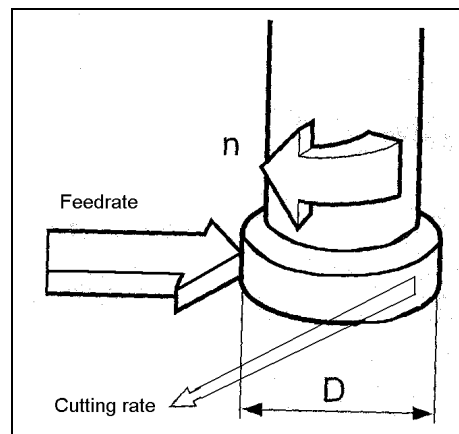

Cutting rate

Traverse at rapid traverse

The programmed path is traversed along a straight line at the fastest possible velocity without the workpiece being machined. Rapid traverse is a non-modal command, i.e. if you want the axis to traverse rapidly in the next block, then you must enter "Rapid traverse" as feedrate (F) again.

If you do not program a feedrate or rapid traverse, the axis is automatically traversed at the last programmed feed value (machining feedrate).

Traverse at feedrate (machining feedrate)

The tool travels at the programmed feedrate F along a straight line or on a circle to the programmed end point and then machines the workpiece. Machining feedrates (F) are specified in mm/min, mm/rev or mm/tooth. With milling cycles, the feedrate is automatically converted both at change from mm/min to mm/rev and when direction is reversed.

With milling cycles, the feedrate for rough cutting is relative to the milling tool center point. This also applies to finish cutting, with the exception of concave curves where the feedrate is relative to the cutting edge (contact point between milling tool and workpiece).

Feedrate in mm/tooth

Mills are multi-edged tools. For this reason, a value must be found which guarantees that each cutting edge can machine the workpiece under the best possible conditions. Feed per tooth corresponds to the linear path traversed by the mill when a tooth is engaged. Feed per tooth is also the effective distance covered by the table feed between the engagement of two successive cutting edges.

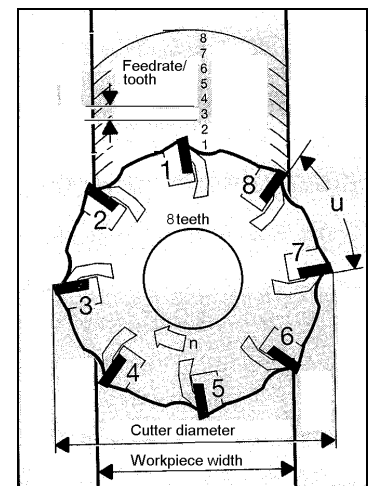
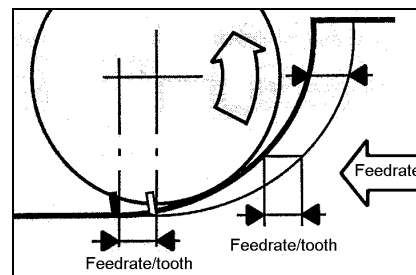

Feedrate in mm/tooth

The machining feedrate is modal, i.e. even if the machining process changes, you need not enter a new feedrate if the feedrate programmed in the preceding block is still appropriate. This applies even if you have programmed a rapid traverse command in between.

3.2 Program structure

The program is divided into 3 subsections:
 Program header, program blocks and program end.
 These subsections form a machining plan.

Program header	P	N5	SHOPMILL
Program blocks		N10	CONTOUR1
		N15	Solid machin. ▽ T=12 F0.1/Z S200rev. Z0=0 Z1=5ink
		N20	CENTERING T=zentrier F200/min S600rev. ø3
		N25	Deep hole dr. T=8 F200/min S70rev. Z1=10ink
		N30	ØØ2: Hole full cir. Z0=0 X0=45 Y0=30 R32 N6
Program end		N35	Right pocket ▽ T=4 F0.2/Z S400rev. X0=60 Y0=80 Z0=0
		N40	Longit. slot ▽ T=9 F0.1/Z S600rev. X0=30 Y0=80 Z0=0
	END	N45	Program end

Program structure

Program header

The program header contains the dimensions of the blank and parameters which are effective throughout the program, e.g.

- dimension in mm or inches
- tool axis X, Y or Z
- return plane, safety clearance, machining direction

Program blocks

To obtain a finished part, you must first program the various machining operations, travel motions, machine commands, etc. The program blocks represent this program.

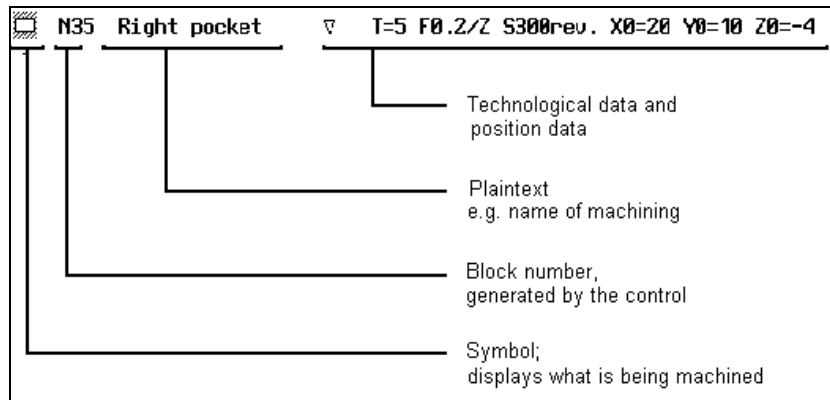

Chained machining

The control automatically chains the technology and position blocks. These blocks are identified by a square bracket immediately beside the machining symbol. The brackets are inserted from the beginning to the end of the sequence of chained blocks.

	N10	Centering
	N15	Deep hole dr.
	N20	Tapping
	N25	ØØ1: Hole full cir.

Blocks N10 ... N25 are chained

3.3 Create a ShopMill program

3.3.1 Create new program; define a blank

Select with soft keys





Enter a program name

Enter a program name.

Program names may be a maximum of 24 characters in length. You can use any letters, digits or the underscore symbol (_). ShopMill automatically changes lower case to upper case.

Confirm the program name by pressing

soft key  or with the "Input" key .

The screenform for setting the "Program header" parameters then appears.

Parameterize the program header

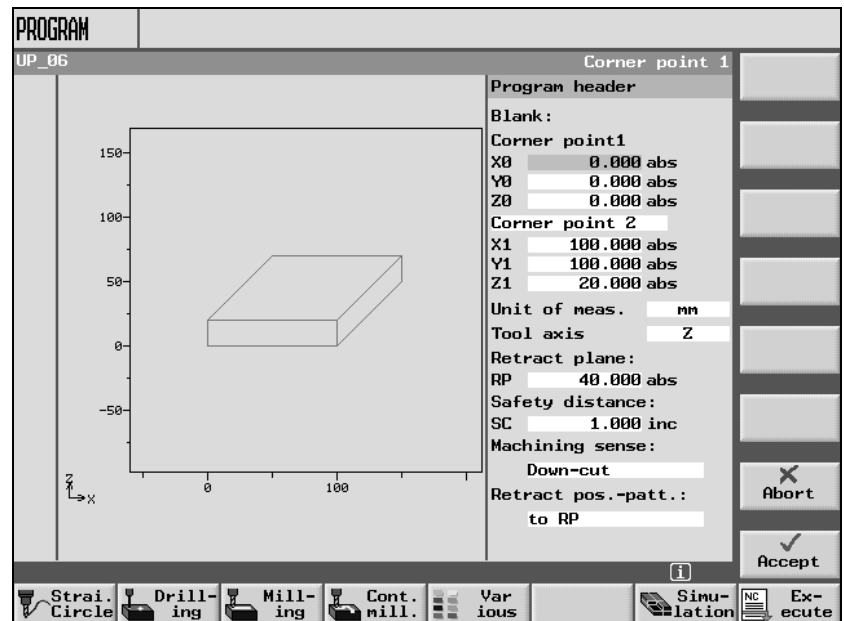

Set the program header parameters

Parameter settings in the program header are valid throughout the entire program.

3.3 Create a ShopMill program

Parameters for input of a blank

- **Workpiece corner point 1 (X0, Y0, Z0):**
Workpiece corner point 1 is the reference point for the blank dimensions. It must be entered as an absolute value.
- **Workpiece corner point 2 or dimensions (X1, Y1, Z1 or L, W, H):**
Workpiece corner point 2 is opposite workpiece corner point 1. It must be entered as an absolute value. The deviations are the length, width and height of the blank.

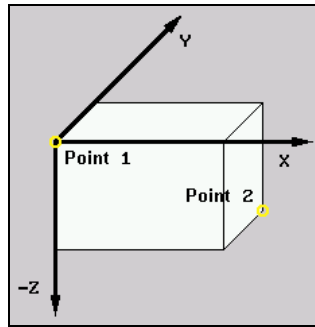

Workpiece corner points 1 and 2

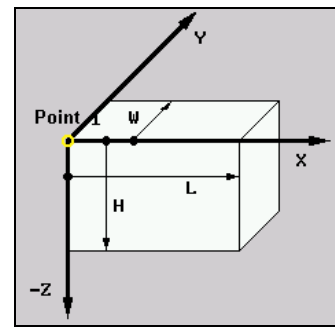

Workpiece corner point 1 and deviations

- **Define unit of measurement** for program [mm or inch].
- **Tool axis:** The tool length is calculated in the set axis.
- **Return plane (RP and safety clearance (SC):**
Planes above workpiece.)
During machining the tool travels in rapid traverse from the tool change point to the return plan and then to the safety clearance. The machining feedrate is activated at this level. When the machining operation is finished, the tool travels at machining feedrate away from the workpiece onto the safety clearance level. It travels from the safety clearance to the return plane and then to the tool change point in rapid traverse. The return plane is entered as an absolute value. The safety clearance must be entered as an incremental value (without sign).

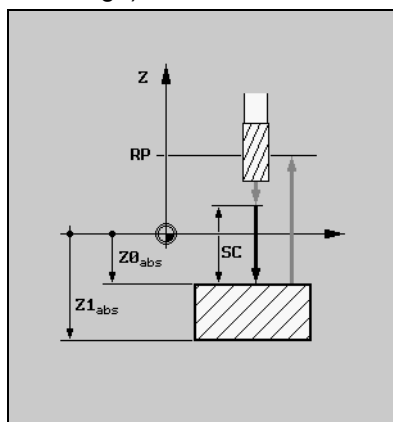

Return plane (RP) and safety clearance (SC)

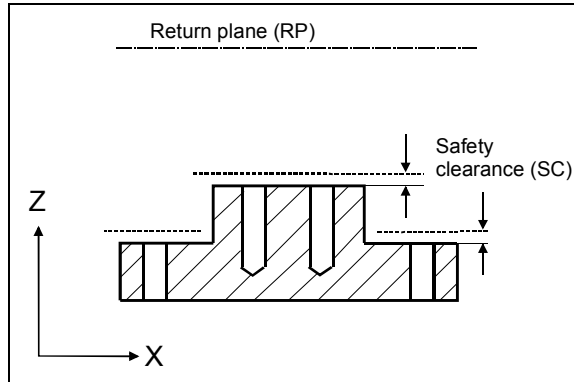

Safety clearance for varying workpiece heights

- **Machining direction:**

When machining a pocket, a longitudinal groove or a spigot, ShopMill applies the machining direction (climb or conventional) and the spindle rotation entered in the tool list. The pocket is then machined in a clockwise or counter-clockwise direction.

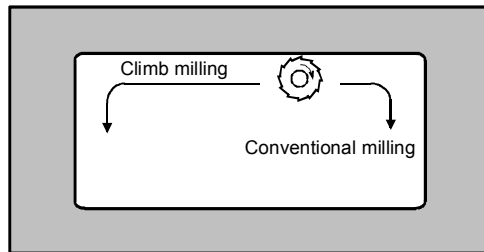

Machining pockets in climb or conventional milling operation with CW spindle rotation

With path milling, the programmed contour direction determines the direction of machining.

- **Retraction with position patterns:**

When working with **optimized retraction**, the tool travels in relation to the contour across the workpiece at machining feedrate and safety clearance (SC). On retraction **to RP**, the tool is retracted to the return plane when the machining step is complete and infeds at the new position. Collisions with workpiece obstacles are thus prevented when the tool is retracted and fed in, e.g. when holes in pockets or grooves are machined at different levels and positions.

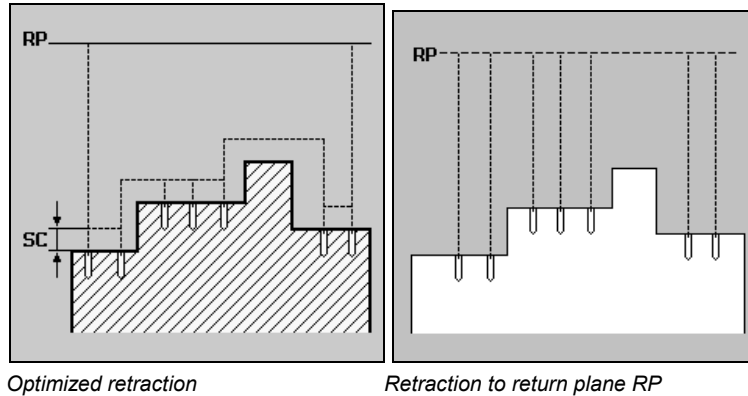
**Store parameters**

Select with soft key

The parameters you have entered are stored. The machining plan is then displayed.

End of program

ShopMill has automatically defined the program end.

3.3.2 Program new blocks**Create program blocks**

Once you have defined the blank, you can define machining operations, feedrates and positions in individual program blocks. You will be supported by "Help" displays for individual machining operations.

There is a limit on the memory space one program can occupy. You can program up to 1,000 program blocks with the "Straight line" function. If you are using other functions that require more memory space, the maximum number of program blocks is reduced accordingly.

Note

New programming blocks are always inserted **after the** selected block. You cannot program blocks before the program header or after program end.

Parameter input fields**Feedrate:**

If you do not program a value for feedrate (F) (empty field), the system uses the last programmed feedrate.

Clear an input field:

Use the DEL key (or Backspace key) to clear an input field, i.e. to delete the programmed value.

Preset (default) or empty parameter fields :

You must always enter a value in fields with a preset default. If you clear a default field, soft key "Accept" disappears from the display!

"Alternat." soft key and toggle key:

If the cursor is positioned on an input field with various setting options, soft key "Alternat." is automatically displayed on the vertical soft key bar (see soft key "Alternat." in Section "Important soft keys for operation and programming").

Roughing/finishing:

Every cycle can be programmed with roughing or finishing. If you wish to rough cut the workpiece first and then finish cut it, you must call the cycle a second time. The programmed values do not change if you call the cycle again.

Some cycles offer roughing and finishing as a **complete machining operation**, i.e. you need only call the cycle once.

Approach a cycle

- Approach the programmed cycles with ShopMill
 - Tool is above the return plane (RP) :
The tool is positioned in rapid traverse in the X/Y plane and then in the Z direction to the return plane (RP)

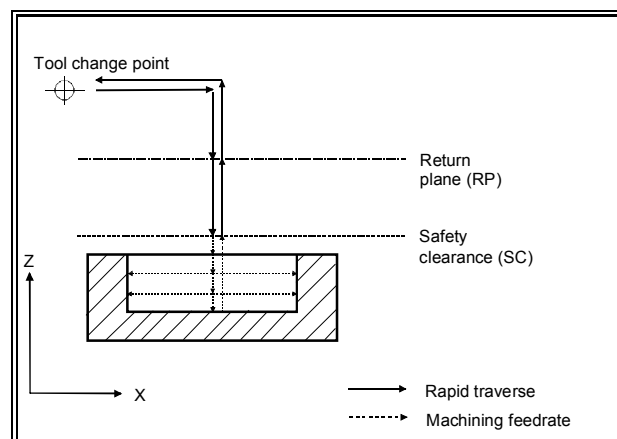

Approach a cycle above the return plane

- or tool is below the return plane (RP) :
The tool is positioned in rapid traverse first in the Z direction to the return plane (RP) and then in rapid traverse in the X/Y plane

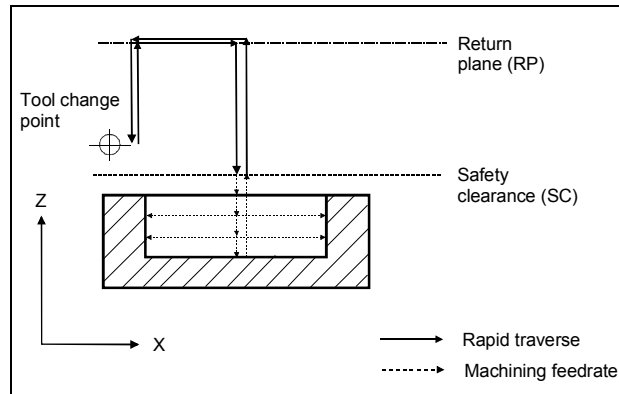

Approach a cycle below the return plane

- Tool axis travels in rapid traverse to safety clearance (SC)
- The cycle is then processed at the programmed machining feedrate
- On completion of machining, the tool travels to the cycle center in the X/Y plane at machining feedrate and then moves away from the workpiece with the tool axis until it reaches safety clearance
- The tool axis then retracts to the return plane in rapid traverse
- The tool change point is approached from the return plane in rapid traverse

3.3.3 Change program blocks



You can optimize the parameters in the programmed ShopMill blocks later or adapt them to new situations, e.g. if you want to increase the feedrate or change a position. You can change all parameters in all program blocks directly in the relevant parameter screen.



- Press the "Program" soft key.

The directory overview is displayed.

- Position the cursor on the directory where you want to open a program.

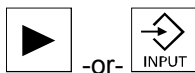

- Press the "Cursor right" or "Input" key.

All programs in this directory are now displayed.

- Select the program you want to modify.

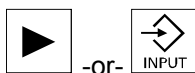

- Press the "Cursor right" or "Input" key.

The machining plan is opened for the program.

- Position the cursor on the desired program block in the machining plan.



- Press the "Cursor right" key.

The parameter screen of the selected program block is displayed.

- Make your required changes.
- Press the "Accept" soft key or the "Cursor left" key.

The changes are validated in the program.

3.3.4 Program editor



Use the program editor if you want to modify the sequence of the program blocks within a program, delete program blocks or copy program blocks from one program to another.



The program editor provides the following functions:

- Select
You can select several program blocks at once, e.g. to cut or copy them.
- Copy/Insert
You can copy and insert program blocks both within the same program and between different programs.
- Cut
You can cut program blocks and delete them this way. The program blocks remain in the clipboard so that you can insert them at another location.
- Search
You can search for block numbers or any string of characters within a program.
- Rename
You can rename a contour in the program editor, e.g. if you have copied the contour from another location.
- Numbering
If you insert a new or copied program block between two existing program blocks, ShopMill automatically generates a new block number. This number might be higher than the block number in the next block. You can use the "Numbering" function to number the program blocks in ascending order.

3.3 Create a ShopMill program



Open the program editor



- Select a program.

- Press the "Expansion" soft key.

The soft keys of the program editor are displayed in the vertical soft key bar.

Select a program block



- Position the cursor in the machining plan on the first or last block you want to select.

- Press the "Mark" soft key.

- Use the cursor keys to highlight all additional program blocks you want to select.

The program blocks are now selected.

Copy a program block

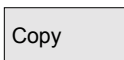

- Select the desired program block(s) in the machining plan.

- Press the "Copy" soft key.

The program blocks are copied to the clipboard.

Cut a program block

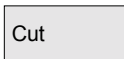

- Select the desired program block(s) in the machining plan.

- Press the "Cut" soft key.

The program blocks are removed from the machining plan and stored in the clipboard.

Insert a program block



- Copy or cut the desired program block(s) in the machining plan.

- Position the cursor on the program block behind which you want to insert the program block(s).

- Press the "Insert" soft key.

The program blocks are inserted in the program's machining plan.

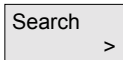
Search

- Select soft key "Search".
- Specify a block number or text.
- Select whether to start the search at the beginning of the program or from the current cursor position.

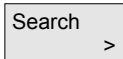

- Select soft key "Search".

ShopMill searches the program. The cursor will be positioned on the search result.

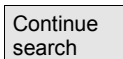

- Press the "Continue search" soft key if you want to continue the search.

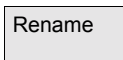
Rename contour

- Position the cursor on a contour in the machining plan.



- Press the "Rename" soft key.
- Specify a new name for the contour.
- Press soft key "OK".

The name of the contour is modified and displayed in the machining plan.

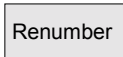
Number program blocks

- Press the "Renumber" soft key.

The program blocks are numbered in ascending sequence.

Exit the program editor

- Exit the program editor by pressing the "Back" soft key.

3.4 Program the tool, offset value and spindle speed

General

When you program cycles, you will find the tool displayed in the screenform. When you program a line or a circular arc, you will have to select a tool beforehand.

Select with soft keys:  

Programming a tool (T)

Select parameter field "T". ShopMill allows you to enter tools in several different ways:

1st way: Enter the name or number of a tool via the keyboard.

2nd way: Press area key "Tool, offset", select a tool with

the cursor keys and select soft key  .

The tool is transferred to the parameter field.

Cutting edge (D)

You can select/specify for each programmed tool whether you want to apply cutting edge offset values D. The offsets are stored in the tool list.

You must program the correct tool edge number D for the different tools (counterbore with spigot, stepped drill, etc.) to avoid risk of collisions (see also Sections "Programming examples for drilling" and "Tools and tool offsets").

Spindle speed (S) or cutting rate (V)

In ShopMill you can program either the spindle speed (S) or the cutting rate (V). You can toggle between them using the "Alternat." key. In the milling cycles, the spindle speed is automatically converted to the cutting rate and vice versa.

- Spindle speed and cutting rate remain valid until you program a new tool.
- Spindle speeds are programmed in rev/min.
- Cutting rates are programmed in m/min
- You can set the direction of rotation of a tool in the tool list.

Allowance (DR)

You can program an allowance on the tool radius in this parameter input field. A finishing allowance is then left when the contour is machined (see also Section "Tools and tool offsets").

Example

You want to leave a finishing allowance of 0.5mm on a contour. DR must then be programmed with 0.5mm. With a setting of DR=0, the programmed contour is cut without a finishing allowance.

3.5 Contour milling**Function**

You can program the following machining operations using the contour milling cycles.

Free contour programming

When programming a freely defined contour, you can input a contour and assign it a contour name. The geometry processor integrated in ShopMill offers the following functions:

- Input of contours with at least two and a maximum of 250 elements
- Programming of additional transition elements (chamfer, radius, tangential transition)
- Input of incompletely dimensioned elements

Select with soft key 

After programming the contour, you can machine the contour with path milling or remove stock from contour pockets with/without islands. This sequence must be adhered to, i.e. first program the geometry for the contour, then specify the technology.

Path milling

Path milling is a machining cycle with which you can machine open and closed contours. The most important functions are:

- Approach and retract strategies
- Finishing allowances for XY plane and Z direction (tool axis)
- Cut segmentation in Z direction (tool axis)

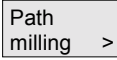
Select with soft key 

Rough-drilling

The rough-drilling function can be used on contour pockets before they are removed. The machining cycle comprises a centering cycle and the actual rough-drilling cycle.

Select with soft key 

Remove pocket with islands

This is a cycle that can machine pockets with or without islands. The pocket and island contours are programmed as a freely defined contour. The cycle offers the following functions:

- Definition of insertion strategy

3.5 Contour milling

- Finishing allowances for XY plane and Z direction (tool axis)
- Cut segmentation in Z direction (tool axis)

Remove residual material

Select with soft key: 

This cycle allows residual material to be removed with a small cutter. It can be useful in cases where the use of a tool with a large diameter has left residual material along the contour, for example, in corners.

Select with soft key: 

Finish a pocket with island

This cycle can be used to finish cut the base of a pocket or the pocket and island contours.

Select with soft key: 

3.5.1 Free contour programming



Function

You can create simple or complex contours and then machine them with "Path milling" or "Solid machining" cycles.

An integrated geometry processor calculates any parameters that are missing provided that it can derive them from other parameters.

The programmed contours are stored at the end of the current program.

Program a new contour and define the starting point

Select with soft keys  

Enter a contour name. This must be a unique name.

If you want to create a contour that is to be similar to an already existing one, you can also copy the old contour, rename it and modify selected contour elements only.

On the other hand, if you want to use an identical contour at another program location, you must not rename the contour. Any changes made to the first contour are automatically made for the contour with the same name.



When entering a contour, start at a position you know and enter this as the starting point. Then define the tool axis. If you alter the tool axis, ShopMill will automatically alter the associated starting point axes.

The starting point is stored with soft key



Transfer the contour to the machining plan

Transfer the programmed contour to the machining plan by pressing soft key "Accept". You can then machine the contour using the machining cycles.

Free contour programming

Beginning at the starting point, enter the first contour element, e.g. straight line. Enter all data specified in the workshop drawing: Length of line, end position, transition to next element, angle of lead, etc. By pressing soft key "All param.", you can display additional parameter input fields for the contour element.

If you do not enter values in some parameter input fields, ShopMill assumes that you do not know what the settings should be and tries to calculate the settings from other parameters.

Additional commands

You can enter any additional commands in the form of G code for each contour element. Additional commands (max. 40 characters) are entered in the Start form and under soft key "All param." for individual contour elements.

For example, you can program deceleration and exact stop for circular contour element "G9".

When a contour is "path milled", it is always machined in the programmed direction. By programming the contour in a clockwise or counter-clockwise direction, you can determine whether the contour is machined in a synchronized operation or reverse rotation operation (see following table).

Outside contour		
Desired machining direction	CW spindle rotation	CCW spindle rotation
Synchronized operation	Programmed in clockwise direction Cutter radius compensation CCW	Programmed in counter-clockwise direction, cutter radius comp. CW
Reverse rotation	Programmed in counter-clockwise direction, cutter radius comp. CW	Programmed in clockwise direction Cutter radius compensation CCW

Inside contour:		
Desired machining direction	CW spindle rotation	CCW spindle rotation
Synchronized operation	Programmed in counter-clockwise direction, cutter radius comp. CCW	Programming in clockwise direction Cutter radius compensation CW
Reverse rotation	Programming in clockwise direction Cutter radius compensation CW	Programmed in counter-clockwise direction, cutter radius comp. CCW

Contours as pockets or islands

Contours for pockets or islands must be closed, i.e. the starting and end points of the contour are identical.

Transition element Chamfer/radius

You can use a transition element whenever there is an intersection between two successive elements which can be calculated from input values. Otherwise you must use a line or circle contour element.

Transition element in closed contours

In a closed contour, you can program a transition element from the last to the first element in the contour. The contour starting point lies outside the contour after you have programmed the transition.

Parameters with gray background

These parameters have been calculated by ShopMill and cannot be altered by the user.

When you alter the programmable parameter input fields (white background), the control calculates new data which are then immediately displayed again in the input form.

Input value is already calculated

If you over-define a contour, ShopMill may automatically calculate a value that you would normally be required to input yourself.

This may cause problems if the input value calculated by the control does not tally with the workshop drawing. If this is the case, you must delete the values from which the control is deriving the incorrect input value. You can then enter the exact setting from the workshop drawing.

Programming graphic

The contour you have programmed is displayed in the programming graphic. Contour elements can be displayed in different line styles and colors:

- **Black:** Programmed contour
- **Red:** Current contour element
- **Green, dotted:** Alternative element
- **Blue:** Partially defined element

The programming graphic displays as much of the contour as the control can interpret on the basis of parameter inputs. If your contour is not displayed in the programming graphic, then you need to enter more data. Check the contour elements you have already programmed if necessary. You may have omitted to enter settings which you know.

3.5.2 Description of soft keys for free contour programming function

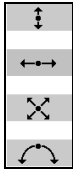

Vertical line

Horizontal line

Diagonal line

Circle / Arc

Cylinder peripheral surface transformation

When the "Cylinder peripheral surface transformation" function is active, the lengths (in circumferential direction of cylinder peripheral surface) of contours can be defined on a cylinder in the form of angular measurements. Depending on the selected axis (selection via display machine data), the start screen and contour element screens display the input in degrees for $X\alpha$, $I\alpha$ or for $Y\alpha$, $J\alpha$ (see also section "Cylinder surface transformation").

Please read the machine manufacturer's instructions.

Tangent to preceding element

The contour element has a tangential transition to the preceding element, thereby setting the angle to the preceding element (α_2) to 0 degrees. The status "tangential" appears in the input field of parameter α_2 .

Select with soft key:

Additional parameter displays

If your drawing contains other data (dimensions) for an element, you can display further input options by pressing soft key "All param.".

Select with soft key:

Descriptions of individual parameters can be found in Section "Description of contour element parameters".

Select a dialog

If your contour involves parameter constellations which permit more than one contour characteristic, the system will request you to select a dialog. Make the correct selection (continuous black line) using soft key "Alternat." and confirm with soft key "Accept".

Select with soft keys:

Alter the selected dialog

If you wish to alter your selected dialog, you must select the contour element for which the dialog selection was made. When you press soft key "Change selection", both dialog alternatives are displayed again. Make the selection again.

Select with soft keys:

3.5 Contour milling

If the selection has been made implicitly from other input values, the system will not request you to make a selection.

Clear a parameter input field

You can clear the programmed value again with the DEL key.

Store a contour element

If you have set all necessary parameters for a contour element or selected the required contour with soft key "Dialog select", store the contour element by pressing soft key "Accept".

Select with soft key: 

You can now program the next contour element.

Change a contour element



Select the programmed contour element that you wish to alter with the cursor keys. Press the "Input" key to display a parameter screenform showing the magnified contour element. You can now change the element parameters and then save them.

If two contours with the same name are defined in your program, changes made to one contour are automatically made to the other contour with the same name.



Delete contour element

Select the contour element you wish to delete with the cursor keys. The selected contour symbol and appropriate contour element in the programming graphic are highlighted in red. Then press soft keys "Delete element" and "OK".

Select with soft keys:  

Close the contour

When you press soft key "Close contour", ShopMill inserts a straight line between your current position and the starting point, thus closing the contour.

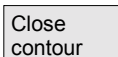
Select with soft key: 

Close and store a contour

Once you have closed the contour, press soft key "Accept" to exit from free contour programming mode. The programmed contour is transferred to the machining plan at the same time.

Select with soft key: 

3.5.3 Description of parameters for line/circle contour elements

Parameters	Description of "Straight line" contour element	Unit
X absolute	Absolute end position in X direction	mm
X incremental	Incremental end position in X direction	mm
Y absolute	Absolute end position in Y direction	
Y incremental	Incremental end position in Y direction	
L	Length of line	mm
α_1	Lead angle in relation to X axis	Degrees
α_2	Angle to preceding element, tangential transition: $\alpha_2=0$	Degrees
Transition to following element	Transition element to next contour is a chamfer (FS) Transition element to next contour is a radius (R) FS=0 or R=0 means no transition element.	mm mm
Additional command	Any additional command in G code form	

Parameters	Description of "Circle" contour element	Unit
X absolute	Absolute end position in X direction	mm
X incremental	Incremental end position in X direction	mm
Y absolute	Absolute end position in Y direction	
Y incremental	Incremental end position in Y direction	
α_1	Start angle in relation to X axis	Degrees
α_2	Angle to preceding element, tangential transition: $\alpha_2=0$	Degrees
β_1	End angle in relation to X axis	Degrees
β_2	Arc angle of circle	Degrees
Direction of rotation	in clockwise or counter-clockwise direction	
R	Radius of circle	mm
I	Position of arc center point in X direction (abs. or incr.)	mm
J	Position of arc center point in Y direction (abs. or incr.)	mm
Transition to following element	Transition element to next contour is a chamfer (FS) Transition element to next contour is a radius (R) FS=0 or R=0 means no transition element.	mm mm
Additional command	Any additional command in G code form	

3.5.4 Programming examples for freely defined contours



Example 1

Starting point: X=0 abs., Y=5.7 abs.

The contour is programmed in a CW direction using dialog selection.

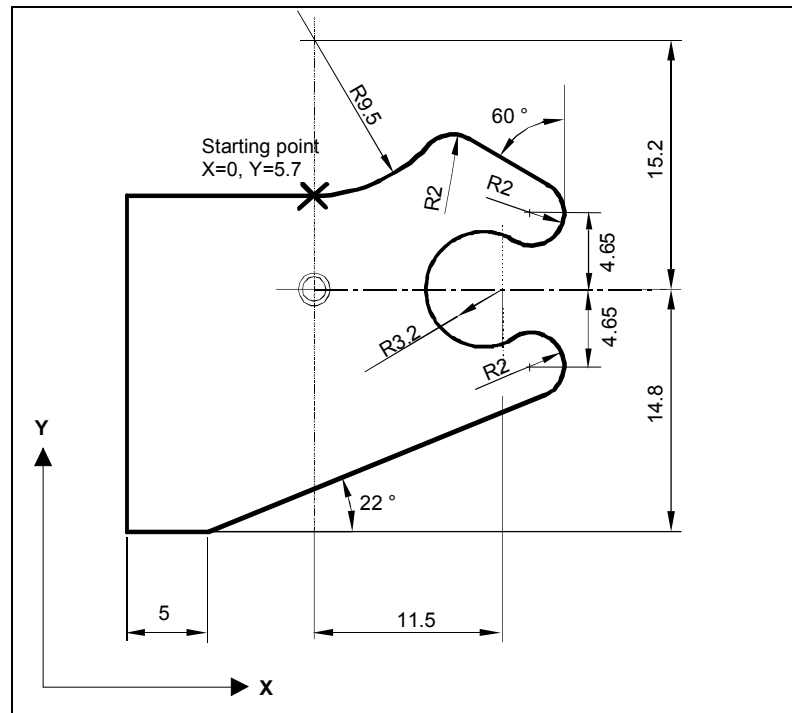

Workshop drawing of contour

Element	Input	Comment
	CCW rotation, R=9.5, I=0 abs., make dialog selection, transition to following element: R=2	
	$\alpha 1 = -30$ degrees	Note the angle in the Help display!
	CW rotation, tangent prev. elem., R=2, J=4.65 abs.	
	CCW rotation, tangent prev. elem. R=3.2, I=11.5 abs., J=0 abs., make dialog selection, make dialog selection	
	CW rotation, tangent prev. elem. R=2, J=-4.65 abs., make dialog selection	
	Tangent to prev. elem. Y=-14.8 abs., $\alpha 1 = -158$ degrees	Note the angle in the Help display!
	All parameters, L=5, make dialog selection	
	Y=5.7 abs.	
	X=0 abs.	



Example 2

Starting point: X=0 abs., Y=0 abs.

The contour is programmed in a CW direction using dialog selection. It is advisable to display all parameters for this contour by selecting the "All param." soft key.

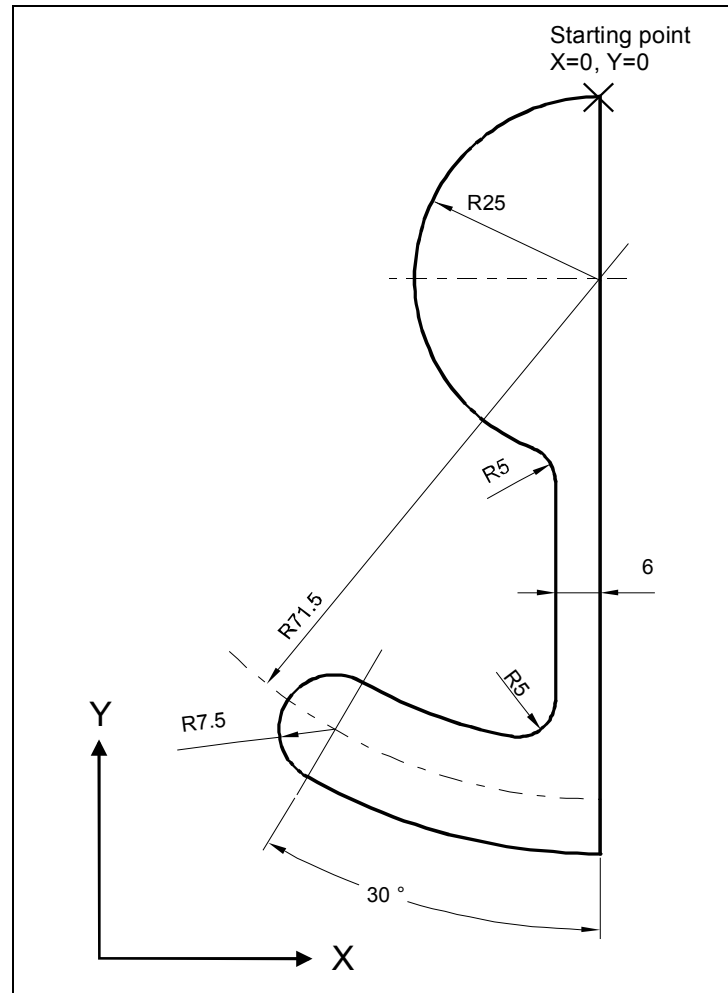

Workshop drawing of contour

Element	Input	Comment
	Y=-104 abs.	
	CW rotation, R=79, I=0 abs., make dialog selection, all parameters, $\beta_2=30$ degrees	
	CW rotation, tangent prev. elem. R=7.5, all parameters, $\beta_2=180$ degrees	
	CCW rotation, R=64, X=-6 abs., I=0 abs., make dialog selection, make dialog selection Transition to following element: R=5	
	All parameters, $\alpha_1=90$ degrees, Transition to following element: R=5	Note the angle in the Help display!
	CW rotation, R=25, X=0 abs., Y=0 abs. I=0 abs., make dialog selection, make dialog selection	



Example 3

Starting point: X=5.67 abs., Y=0 abs.

The contour is programmed in a counter-clockwise direction.

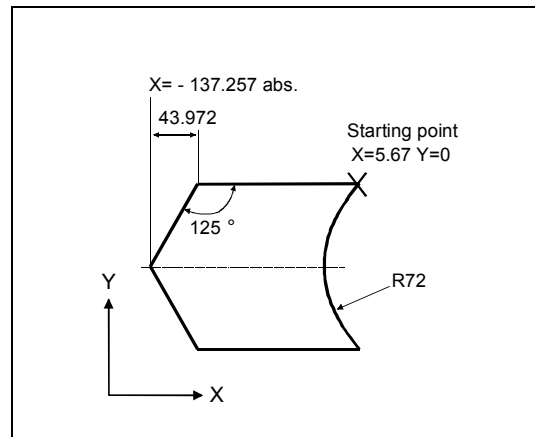

Workshop drawing of contour

Element	Input	Comment
	All parameters, $\alpha_1=180$ degrees	Note the angle in the Help display!
	X=-43.972 inc, all parameters X=-137.257 abs, $\alpha_1=-125$ degrees	Coordinate X in "abs" and in "inc" Note the angle in the Help display!
	X=43.972 inc $\alpha_1=-55$ degrees	Coordinate X in "abs" and in "inc" Note the angle in the Help display!
	X=5.67 abs	
	CW rotation, R=72, X=5.67 abs., Y=0 abs., make dialog selection	

3.5.5 Path milling of open and closed contours



Function

You can mill along any contour you have programmed with the "Path milling" function. The function operates with cutter radius compensation.

The contour does not have to be closed. You can perform any of the following operations:

- Inside or outside machining (on left or right of the contour).
- Machining along center-point path

Select with soft key



Path milling on right or left of the contour A programmed contour can be machined with the cutter radius on the right or left. You can also select various modes and strategies of approach and retraction from the contour.

Approach/retraction mode The tool can approach or retract from the contour along a quadrant, semi-circle or straight line.

- With a quadrant or semi-circle approach path, you must enter the current center point path.
- With a straight line, you must specify the distance between the cutter outer edge and the contour start or end point.

You can also program a mixture of modes, e.g. approach along quadrant, retract along semi-circle.

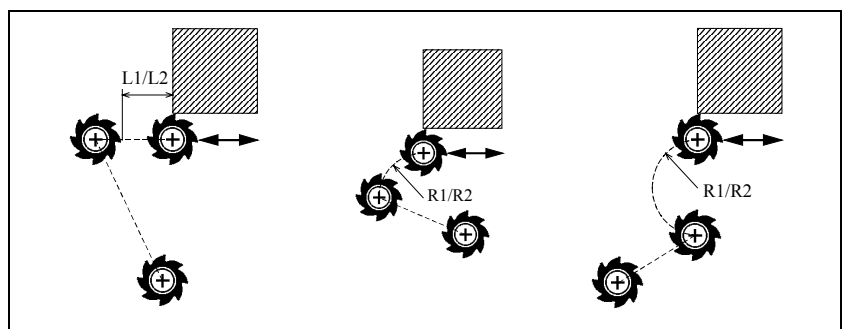

Approach and retraction along straight line, quadrant and semi-circle; ($L1$ =approach length, $L2$ =retract length, $R1$ =approach radius, $R2$ =retract radius)

3.5 Contour milling

Approach/retraction strategy You can choose between planar approach/retraction and spatial approach/retraction:

- **Planar approach:** The tool first approaches in the Z direction (machining depth) and then in the XY plane.
- **Spatial approach:** The tool approaches in depth and plane simultaneously.
- **Retraction** takes place in the opposite order. You can program a mixture of strategies, e.g. planar approach, spatial retraction.

Path milling along the center-point path

A programmed contour can also be machined along the center-point path if the operation has been activated under radius compensation





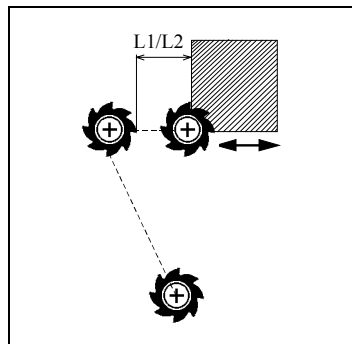



(no radius compensation). In this instance, the tool can approach and retract only along a straight line since the control cannot determine which side the contour must be approached from.



Approach and retraction in a straight line on center-point path (L1=approach length, L2=retraction length)



Parameters	Description	Unit
T, F, S, V	See Section "Program tool, offset value and spindle speed".	
Radius compensation	Machining on left of contour 	
	Machining on right of contour 	
	Machining along center-point path 	
Machining type	<input type="checkbox"/> Roughing <input type="checkbox"/> Finishing	
Z0	Reference plane (abs. or incr.)	
Z1	Final depth (abs. or incr.)	mm
DZ	Infeed depth	mm
UZ	Finishing allowance on base	mm
UXY	Finishing allowance on edge (not applicable to center-point path machining operations)	mm
Approach mode	along a quadrant (segment of a spiral) *) along a semicircle (segment of a spiral) *) along a straight line (oblique line in space)	
Approach strategy	planar 	
	spatial 	
R1 or L1	Approach radius *), approach length	
Retraction mode	along a quadrant (segment of a spiral) *) along a semicircle (segment of a spiral) *) along a straight line (oblique line in space)	
Retraction strategy	planar 	
	spatial 	
R2 or L2	Retraction radius *), retraction length	
Select lift-off mode	If several depth infeeds are necessary, specify the retraction height, i.e. the height the tool is to retract to between the individual infeeds (at transition from end of contour to start). Z0 + safety clearance By safety clearance To return plane No retraction	

*) applies only to path milling on left and right of contour

3.5.6 Rough drilling in contour pockets



Function

If a milling tool cannot be inserted in the center to remove stock from contour pockets, it is necessary to rough-drill first.

The number and positions of the required rough drill holes depends on certain conditions, e.g. type of contour, tool, plane infeed, finishing allowances.

The rough-drilling cycle comprises a centering cycle and the actual rough-drilling cycle.

The drilling positions in the contour pocket cycle are determined when the contour pocket is calculated. This calculation generates a special drilling program that is called in the rough drilling cycles (centering and rough drilling).

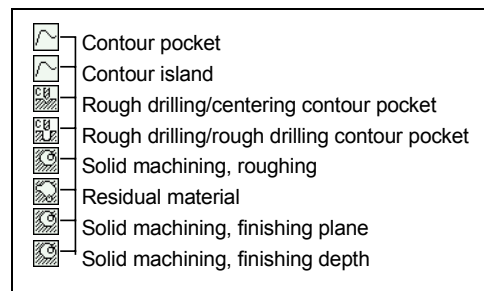

Example of a chain containing rough drilling (centering and rough drilling) and solid machining

If you are milling more than one pocket and want to avoid unnecessary tool changes, it is advisable to rough-drill all pockets first and then remove stock. In this case, for centering/rough-drilling you have to set all additional parameters that appear when you press the "All parameters" soft key. Then proceed as follows for programming:

1. Contour pocket 1
2. Centering
3. Contour pocket 2
4. Centering
5. Contour pocket 1
6. Rough drilling
7. Contour pocket 2
8. Rough drilling
9. Contour pocket 1
10. Solid machining
11. Contour pocket 2
12. Solid machining

If you are doing all the machining for the pocket at once, i.e. centering, rough-drilling and removing stock directly in sequence, and do not set



the additional parameters for centering/rough-drilling, ShopMill will take these parameter values from the stock removal (roughing) machining step.

Centering

Select with soft keys

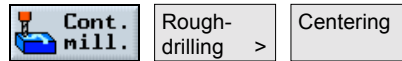

Select key  to call Help display

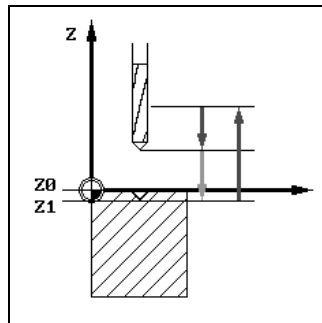

Centering in contour pocket



Parameters	Description	Unit
T, F, S	See Section "Program tool, offset value and spindle speed".	
TR	Reference tool for centering	
Z0	Workpiece height (abs.)	mm
Z1	Depth in relation to Z0 (incr.)	mm
DXY	Max. infeed plane Alternatively, you can specify the plane infeed as a %, as the ratio --> plane infeed (mm) to milling cutter diameter (mm).	mm %
UXY	Finishing allowance, plane	mm
Select lift-off mode	Liftoff mode before new infeed If a machining operation requires several insertion points, you can program the retraction height: <ul style="list-style-type: none"> To return plane Z0 + safety clearance On making the transition to the next insertion point, the tool returns to this height. If there are no elements larger than Z0 in the pocket area, "Z0 + safety clearance" can be selected as the lift-off mode.	mm mm

Rough drilling

Select with soft keys

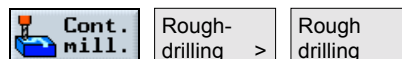

3.5 Contour milling



Select key
to call Help display

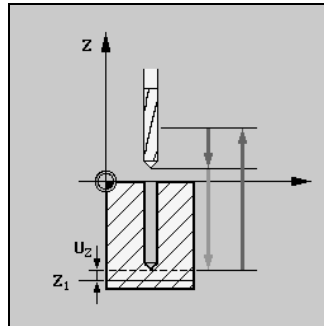

Rough drilling a contour pocket



Parameters	Description	Unit
T, F, S	See Section "Program tool, offset value and spindle speed".	
TR	Reference tool for rough-drilling	
Z0	Workpiece height (abs.)	mm
Z1	Depth in relation to Z0 (incr.)	mm
DXY	Max. infeed plane Alternatively, you can specify the plane infeed as a %, as the ratio --> plane infeed (mm) to milling cutter diameter (mm).	mm %
UXY	Finishing allowance, plane	mm
UZ	Finishing allowance, depth	mm
Select lift-off mode	Liftoff mode before new infeed If a machining operation requires several insertion points, you can program the retraction height: <ul style="list-style-type: none"> To return plane Z0 + safety clearance On making the transition to the next insertion point, the tool returns to this height. If there are no elements larger than Z0 in the pocket area, "Z0 + safety clearance" can be selected as the lift-off mode.	mm mm

3.5.7 Machine (rough cut) pocket with islands



Function

Before you can machine a pocket with islands, you must enter the contour of the pocket and islands (see Section "Free contour programming"). The first contour you specify is interpreted as the pocket contour and all the others as islands.

Using the programmed contours and the input screen form for solid machining, ShopMill generates a program which removes the pockets with islands from inside to outside in parallel to the contour. The direction is determined by the direction of rotation specified in the program header for machining (reverse or synchronous).

The islands may lie partially outside the pocket or overlap one another.

Select with soft key



Select key
to call Help display

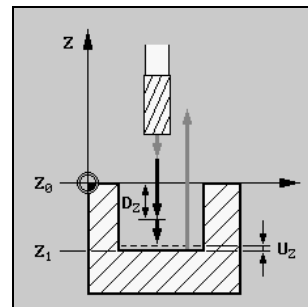
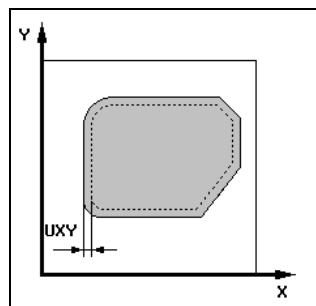

Help displays for solid machining



Parameters	Description	Unit
T, F, V	See Section "Program tool, offset value and spindle speed".	
Machining type	<input checked="" type="checkbox"/> Roughing	mm
Z0	Workpiece height (abs.)	mm
Z1	Depth in relation to Z0 (abs. or incr.)	mm
DXY	Max. infeed in X/Y plane. Alternatively, you can specify the plane infeed as a %, as a ratio → plane infeed (mm) to milling cutter diameter (mm).	mm %
DZ	Max. infeed depth (abs. or incr.)	mm
UXY	Finishing allowance, plane	mm
ZU	Finishing allowance, depth	mm
Starting point	The starting point can be calculated automatically or entered manually .	
X	Starting point X (abs.), manual input only	mm
Y	Starting point Y (abs.), manual input only	mm

3.5 Contour milling

Insertion	<p>Oscillation: The tool is inserted in oscillating mode at the programmed angle (EW).</p> <p>Helical: The tool is inserted along a helical path with the programmed radius (ER) and programmed pitch (EP).</p> <p>Center: This insertion strategy requires a cutter which cuts across center. It is inserted at the programmed feedrate (FZ).</p>	
EW	Insertion angle (for oscillation only)	Degrees
FZ	Feedrate FZ (for Center only)	mm/min
EP	Insertion pitch (for Helical only)	mm/rev
ER	Insertion radius (for Helical only)	mm
Select lift-off mode	<p>If the machining operation requires several points of insertion, the retraction height must be programmed:</p> <ul style="list-style-type: none"> To return plane Z0 + safety clearance (SC) <p>On making the transition to the next insertion point, the tool returns to this height. If the pocket area does not contain any elements larger than Z0, then Z0 + safety clearance (SC) can be programmed as the lift-off mode.</p>	<p>mm</p> <p>mm</p>



When input manually, the starting point can also be located outside the pocket. This can be useful, for example, when machining a pocket which is open on one side. The machining operation then begins without insertion with a linear movement into the open side of the pocket.

3.5.8 Remove residual material



Function

If you have removed stock in a pocket (with/without islands) and residual material still remains, ShopMill will detect this automatically. You can remove this residual material with a suitable tool without having to machine the entire pocket again, i.e. no unnecessary operations.

Material that remains as a final machining allowance is not residual material.

The residual material is calculated on the basis of the milling tool used for stock removal.

If you are milling more than one pocket and want to avoid unnecessary tool changes, it is advisable to remove stock from all pockets first and then remove the residual material. In this case, for removing residual material, you also have to set the Reference tool TR parameter which appears when you press the "All parameters" soft key. Then proceed as follows for programming:

1. Contour pocket 1
2. Solid machining
3. Contour pocket 2
4. Solid machining
5. Contour pocket 1
6. Remove residual material
7. Contour pocket 2
8. Remove residual material

The "Residual material" function is a software option.

Select with soft key



Select key
to call Help display

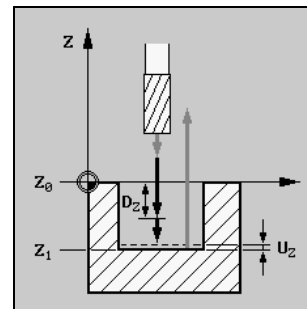
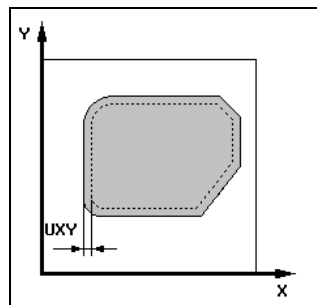

Help display for residual material

Parameters	Description	Unit
T, F, V	See Section "Program tool, offset value and spindle speed".	
Machining type	<input checked="" type="checkbox"/> Roughing	
TR	Reference tool for residual material	
Z0	Workpiece height (abs.)	mm
Z1	Depth in relation to Z0 (abs. or incr.)	mm
DXY	Max. infeed, plane Alternatively, you can specify the plane infeed as a %, as a ratio --> plane infeed (mm) to milling cutter diameter (mm).	mm %
DZ	Max. infeed, depth	mm
UXY	Finishing allowance, plane	mm
UZ	Finishing allowance, depth	mm
Select lift-off mode	If the machining operation requires several points of insertion, the retraction height can be programmed: <ul style="list-style-type: none"> • To return plane • Z0 + safety clearance (SC) On making the transition to the next insertion point, the tool returns to this height. If the pocket area does not contain any elements larger than Z0, then Z0 + safety clearance (SC) can be programmed as the lift-off mode.	mm mm

3.5.9 Finish pocket with islands



Function

If for removing stock from the pocket, you have programmed a final machining allowance for the pocket base/edge, you also finish cut the pocket.

For finish cutting the base and edge, you must program a separate block for each operation. The pocket is only machined once though. When finish cutting, ShopMill takes any existing island(s) into account as is the case for rough cutting.

Select with soft key



Select the "Finish cutting base" or "Finish cutting edge" machining type.

Select key
to call Help display

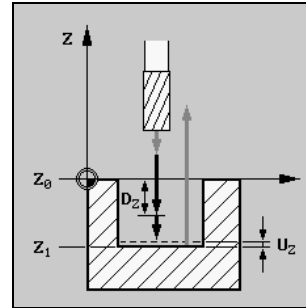
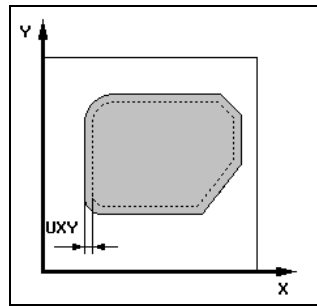

Help display for "Finish pocket with islands"

Parameters	Description of finish cut along base:	Unit
T, F, V	See Section "Program tool, offset value and spindle speed".	
Machining type	▽▽▽ Finishing on base	
Z0	Workpiece height (abs.)	mm
Z1	Depth in relation to Z0 (abs. or incr.)	mm
DXY	Max. infeed, plane Alternatively, you can specify the plane infeed as a %, as a ratio --> plane infeed (mm) to milling cutter diameter (mm).	mm %
UXY	Finishing allowance, plane	mm
UZ	Finishing allowance, depth	mm
Starting point	The starting point can be determined automatically or entered manually. When entered manually, the starting point can be positioned outside the pocket. In this case, the tool first machines along a straight line into the pocket, e.g. for a pocket open on the side without insertion.	
X	Coordinate of starting point (abs.), manual input only	mm
Y	Coordinate of starting point (abs.), manual input only	mm

Insertion	Oscillation: The tool is inserted at the programmed angle (EW). Helical: The tool is inserted along a helical path with the programmed radius (ER) and programmed pitch (EP). Center: This insertion strategy requires a cutter which cuts across center. It is inserted at the programmed feedrate (FZ).	
EW	Insertion angle (for oscillation only)	Degrees
EP	Insertion pitch (for Helical only)	mm/rev
ER	Insertion radius (for Helical only)	mm
FZ	Feedrate FZ (for Center only)	mm/min
Select lift-off mode	If the machining operation requires several points of insertion, the retraction height can be programmed: <ul style="list-style-type: none"> To return plane Z0 + safety clearance (SC) On making the transition to the next insertion point, the tool returns to this height. If the pocket area does not contain any elements larger than Z0, then Z0 + safety clearance (SC) can be programmed as the lift-off mode.	mm mm



Parameters	Description of finish cut along edge:	Unit
T, F, V	See Section "Program tool, offset value and spindle speed".	
Machining type	∇∇∇ Finishing on edge	
Z0	Workpiece height (abs.)	mm
Z1	Depth in relation to Z0 (abs. or incr.)	mm
DZ	Max. infeed, depth	mm
UXY	Finishing allowance, plane	mm
Select lift-off mode	If the machining operation requires several points of insertion, the retraction height can be programmed: <ul style="list-style-type: none"> To return plane Z0 + safety clearance (SC) On making the transition to the next insertion point, the tool returns to this height. If the pocket area does not contain any elements larger than Z0, then Z0 + safety clearance (SC) can be programmed as the lift-off mode.	mm mm
	Note: An alternative to the "Edge finish cut" option is the "Path milling" function which offers greater optimization potential (approach and retract strategies and modes).	

3.6 Straight line or circular path motions

This function is intended for the implementation of very simple machining operations as path movements.

More complex operations such as contours with chamfers, radii, approach strategies, tangential transitions, etc. should be implemented using the "Mill contour" and "Path milling" functions.

You must program a tool before you program simple lines or circles. A tool with spindle speed is selected by means of soft keys "Straight circle" and "Tool".

You can only program rapid traverse for linear travel motions.

3.6.1 Line



Radius compensation

Function

The tool moves at the programmed feedrate or in rapid traverse from its current position to the programmed end position.

If you choose, you can execute the straight line with radius compensation. Radius compensation has a modal action, i.e. you have to deselect radius compensation again if you want to traverse without it. And, with several consecutive straight lines with radius compensation, you can only select radius compensation in the first program block.

When executing the first path motion with radius compensation, the tool traverses without compensation at the starting point and with compensation at the end point, i.e. when a vertical path is programmed, the tool traverses an oblique path. The compensation is not applied over the entire traversing path until the second programmed path motion with radius compensation is executed. The effect is reversed when you deselect radius compensation.

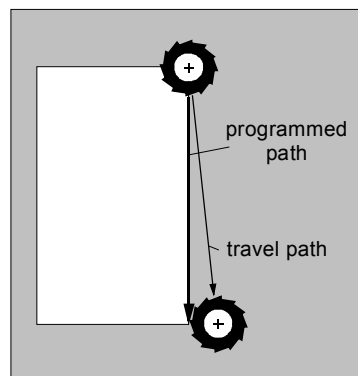

First path motion with radius compensation

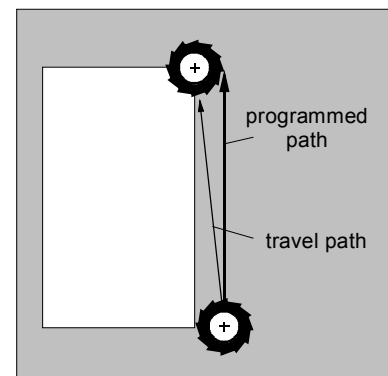

First path motion with deselected radius compensation

To avoid deviation between the programmed and actually traversed path, you can program the first path motion with radius compensation or deselected radius compensation outside the workpiece. You cannot program a motion without specifying coordinates.



3.6 Straight line or circular path motions

Select with soft keys



Select key to call Help display

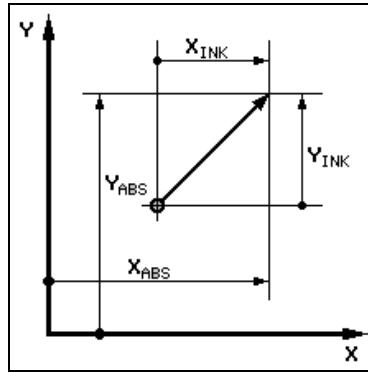

Help display for a line



Parameters	Description	Unit
X	Coordinate of end point in X direction (abs. or incr.)	mm
Y	Coordinate of end point in Y direction (abs. or incr.)	mm
Z	Coordinate of end point in Z direction (abs. or incr.)	mm
Radius compensation	Input defining which side of the contour the cutter travels in the programmed direction: <input checked="" type="checkbox"/> Radius compensation, left of contour <input checked="" type="checkbox"/> Radius compensation, right of contour <input checked="" type="checkbox"/> Radius compensation off <input type="checkbox"/> Radius compensation is retained as set	

3.6.2 Circle with known center point



Function

The tool travels along a circular path from its current position to the programmed circle end point. You must know the position of the circle center point. The control calculates the radius of the circle/arc on the basis of your interpolation parameter settings.

The circle can only be traversed at machining feedrate. You must program a tool before the circle can be traversed.

Select with soft keys

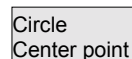
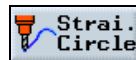

Select key to call Help display

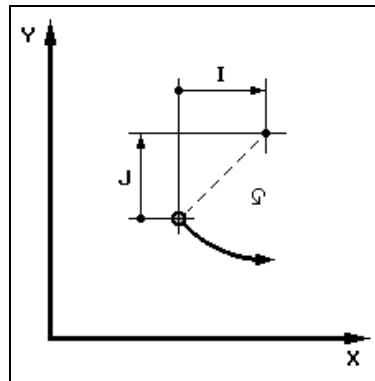

Help display for circle with known center point



Parameters	Description	Unit
Direction of rotation	The tool travels in the programmed direction from the circle start point to its end point. You can program this direction as clockwise or counter-clockwise.	
X	X position circle end point (abs. or incr.)	mm
Y	Y position circle end point (abs. or incr.)	mm
I	Distance between circle start and center point in X direction (incr.)	mm
J	Distance between circle start and center point in Y direction (incr.)	mm
Plane	The circle is traversed in the set plane with the relevant interpolation parameters: XYIJ: XY plane with interpolation parameters I and J XZIK: XZ plane with interpolation parameters I and K YZJK: YZ plane with interpolation parameters J and K	mm mm mm

3.6.3 Circle with known radius



Function

The tool traverses a circular path with the programmed radius from its current position to the programmed circle end point. The control system works out the circle center point. You do not need to program interpolation parameters.

The circle can only be traversed at machining feedrate.

Select with soft keys



Circle
Radius

Select key
to call Help display

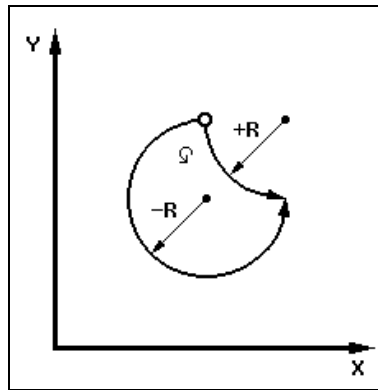

Help display for circle with known radius



Parameters	Description	Unit
Direction of rotation	The tool travels in the programmed direction from the circle start point to its end point. You can program this direction as clockwise or counter-clockwise.	
X	X position circle end point (abs. or incr.)	mm
Y	Y position circle end point (abs. or incr.)	mm
R	Radius of arc; You can select the arc of your choice by entering a positive or a negative sign.	mm

3.6.4 Helix



Function

With helical interpolation, a circular movement is overlaid in the plane with a linear motion in the tool axis, i.e. a spiral is created.

Select with soft keys



Select key
to call Help display

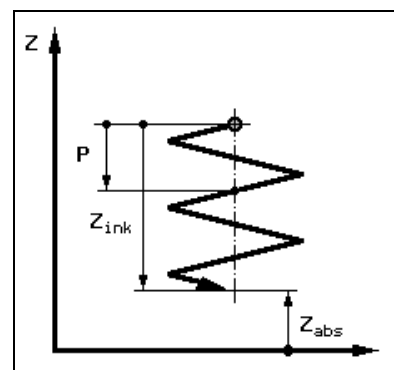
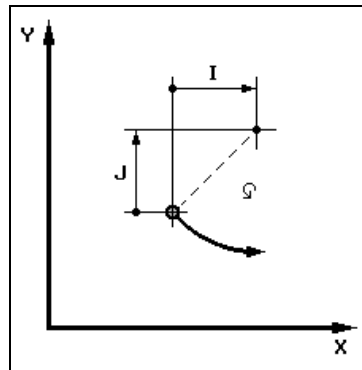

Help display for a helix



Parameters	Description	Unit
Direction of rotation	The tool travels in the programmed direction from the circle start point to its end point. You can program this direction as clockwise or counter-clockwise.	
I, J	Incremental: Distance between helix start and center point in X and Y directions Absolute: Center point of helix in X and Y directions	mm
P	Pitch of helix; The pitch is programmed in mm per revolution.	mm/360 °
Z	Z position of helix end point (abs. or incr.)	mm

3.6.5 Polar coordinates

**Function**

If a workpiece has been dimensioned from a central point (pole) with radius and angles, you will find it helpful to program these as polar coordinates.

You can program straight lines and circles as polar coordinates.

Define a pole

You must define the pole before you can program a line or circle in polar coordinates. This pole acts as the reference point of the polar coordinate system.

The angle for the first line or circle then needs to be programmed in absolute coordinates. You can program the angles for any further lines and circles as either absolute or incremental coordinates.

Select with soft keys

Polar

Pole



Parameters	Description	Unit
X	X position of pole (abs. or incr.)	mm
Y	Y position of pole (abs. or incr.)	mm

3.6.6 Polar line



Function

A straight line in the polar coordinate system is defined by a radius (L) and an angle (α). The angle refers to the X axis.

The tool moves from its current position on a straight line to the programmed end point at the machining feedrate or in rapid traverse.

The 1st line in polar coordinates entered after the pole must be programmed with an absolute angle. You can program any further lines or circles with incremental coordinates.

Select with soft keys



Select key
to call Help display

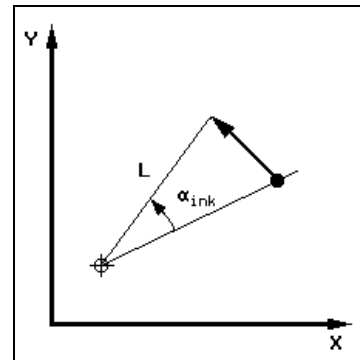
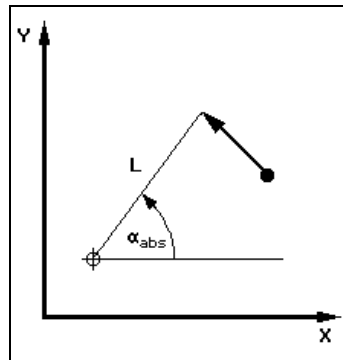

Help display for polar line with absolute and incremental angle

Parameters	Description	Unit
L	Radius from pole to end point of line	mm
α	Polar angle (abs. or incr., positive or negative)	Degrees
Radius compensation	Input defining which side of the contour the cutter travels in the programmed direction: <input checked="" type="checkbox"/> Radius compensation, left of contour <input checked="" type="checkbox"/> Radius compensation, right of contour <input checked="" type="checkbox"/> Radius compensation off <input type="checkbox"/> Radius compensation is retained as set	

3.6.7 Polar circle



Function

A circle in the polar coordinate system is defined by an angle (α). The angle refers to the X axis.

The tool moves from its current position on a circular path to the programmed end point (angle) at the machining feedrate.

The radius corresponds to the distance from the current tool position to the defined pole, i.e. the circle start and end point positions are at the same distance from the defined pole.

The 1st circle in polar coordinates entered after the pole must be programmed with an absolute angle. You can program any further lines or circles with incremental coordinates.

Select with soft keys



Polar

Straight
Polar



Select key
to call Help display

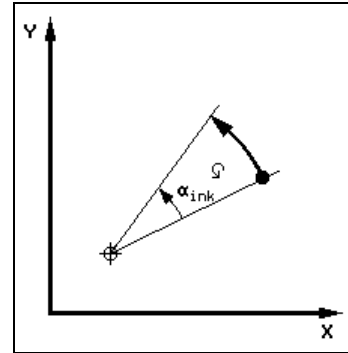
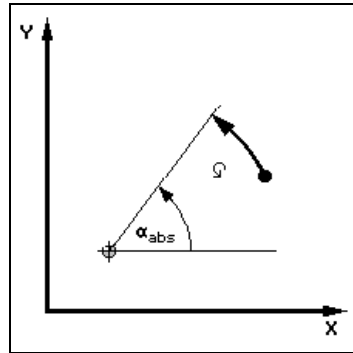

Help display for polar circle with absolute and incremental angle



Parameters	Description	Unit
Direction of rotation	The tool travels in the programmed direction from the circle start point to its end point. You can program this direction as clockwise (right) or counter-clockwise (left).	
α	Polar angle (abs. or incr., positive or negative)	Degrees

3.6.8 Programming examples for polar coordinates



Program a pentagon

You want to machine the outside contour of a pentagon.

Make sure that you enter the correct workpiece dimensions!

Approach start point in rapid traverse: X70, Y50, radius compensation off.

Pole: X=50, Y=50

1. 1st polar line: L=20, $\alpha = -72$ **absolute**, radius compensation right
2. 2nd to 5th polar line: L=20, $\alpha = -72$ degrees **incremental**,
Radius compensation right

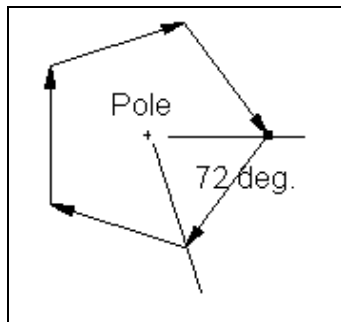

→	N10	RAPID	X70	Y50	Z2
⊕	N15	X50	Y50		
→	N20	L20	$\alpha -72$		
→	N25	L20	$\alpha -72$ inc		
→	N30	L20	$\alpha -72$ inc		
→	N35	L20	$\alpha -72$ inc		
→	N40	L20	$\alpha -72$ inc		
→	N45	L20	$\alpha -72$ inc		
END	N50 Program end				

Programming graphic and extract from machining plan



Program an arc of 225 degrees

You want to machine the outside contour of an arc.

Make sure that you enter the correct workpiece dimensions!

Approach start point in rapid traverse: X=80, Y=50, radius compensation right

Pole: X=60, Y=50

CW rotation, $\alpha = 135$ degrees absolute

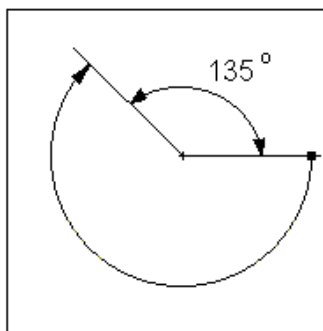

→	N5	RAPID	X80	Y50	Z2
⊕	N10	X60	Y50		
↷	N15	F200/min	$\alpha 135$		
END	Program end				

Programming graphic and extract from machining plan

3.7 Drilling

Program holes and threads In ShopMill, first program the technology blocks in the exact order in which they need to be performed, e.g.

1. **Centering**, with tool and input of spindle speed and machining feedrate
2. **Deep-hole drilling**, with tool and input of spindle speed and machining feedrate
3. **Tapping** with tool and input of spindle speed and machining feedrate

Once you have programmed the technologies, you need to enter the **position data**. ShopMill provides various positioning patterns (see Section "Positions").

This sequence, first technology block and then positioning block must be adhered to in drilling cycles.

3.7.1 Centering



Function

The tool is moved in rapid traverse to the position to be centered, allowing for the return plane and safety clearance. The tool is inserted into the workpiece at programmed feedrate (F) until it reaches Z1 or until the surface diameter is the correct size. When the dwell time expires, the tool is retracted in rapid traverse to either the return plane or the safety clearance depending on the setting in parameter "Retraction position pattern". You will find parameter "Retraction position pattern" in the program header or under "Settings" in the "Miscellaneous" menu.

Select with soft keys

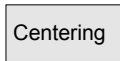

Select key
to call Help display

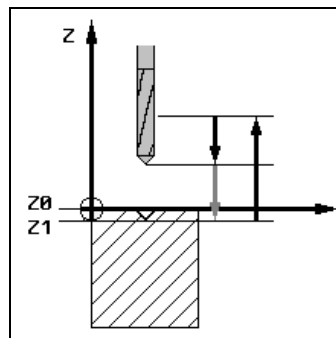

Help display for centering at depth

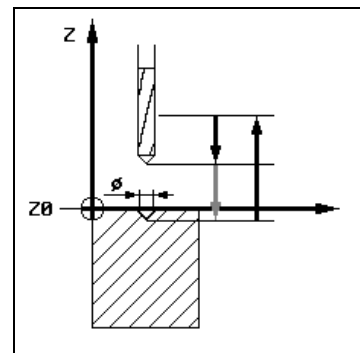

Help display for centering on diameter



Parameters	Description	Unit
T, D, F, S, V	See Section "Program tool, offset value and spindle speed".	
Diameter	The tool is inserted into the workpiece until the diameter on the surface is the correct size. The angle for the center drill entered in the tool list is applied in this case.	
Tip	The drill is inserted into the workpiece until the programmed insertion depth is reached.	
∅	It is inserted into the workpiece until the diameter is correct.	mm
Z1	It is inserted into the workpiece until it reaches Z1.	mm
Z0	Height of workpiece; Z0 is specified in the position pattern ("Positioning" soft key).	mm
DT	Dwell time for relief cut	s U

3.7.2 Drilling and reaming



Function

The tool is moved in rapid traverse to the programmed position, allowing for the return plane and safety clearance. It is then inserted into the workpiece at the feedrate programmed under F until it reaches depth Z1.

Drilling: If Z1 has been reached and the dwell time expired, the drill is retracted at rapid traverse either to the return plane or the safety clearance depending on the setting in parameter "Retraction position pattern". You will find parameter "Retraction position pattern" in the program header or under "Settings" in the "Miscellaneous" menu.

Reaming: If Z1 has been reached and the dwell time expired, the reamer is retracted at the programmed retraction feedrate to the safety clearance.

Select with soft keys

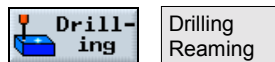

Select key to call Help display

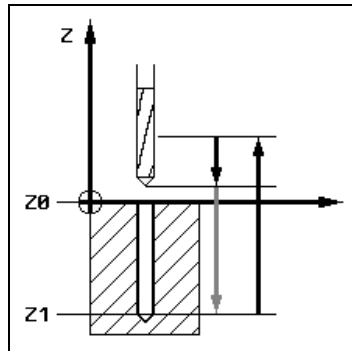

Help display for drilling

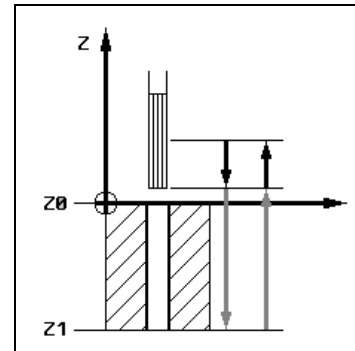

Help display for reaming

Parameters	Description	Unit
T, D, F, S, V	See Section "Program tool, offset value and spindle speed".	
Shank	The drill is inserted into the workpiece until the drill shank reaches the value programmed for Z1. The insertion angle entered in the tool list is applied.	
Tip	The drill is inserted into the workpiece until the drill tip reaches the value programmed for Z1 (does not apply in reaming).	
Z1	Insertion depth for drill tip or drill shank.	mm
Z0	Height of workpiece; Z0 is specified in the position pattern ("Positioning" soft key).	mm
DT	Dwell time for relief cut	s U
FB	Retraction feedrate (for reaming only)	

3.7.3 Deep-hole drilling



Function

The tool is moved in rapid traverse to the programmed position, allowing for the return plane and safety clearance. It is then inserted into the workpiece at the programmed feedrate.

Select with soft keys

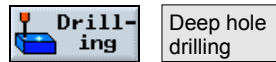

Stock removal

The tool drills at the programmed feedrate (F) until the 1st infeed depth is reached. On reaching the 1st depth, the tool is retracted from the workpiece at rapid traverse for stock removal and is then re-inserted at the 1st infeed depth reduced by a clearance distance (V3). The tool then drills to the next infeed depth and is then retracted again, repeating this process until the final drill depth (Z1) is reached. On expiry of the dwell time (DT), the tool is retracted at rapid traverse to the safety clearance.

Chip breaking

The tool drills at the programmed feedrate (F) until the 1st infeed depth is reached. Once this depth is reached, the tool is retracted by a withdrawal distance (V2) for chip breaking and is then inserted again down to the next drilling depth. It repeats this process until the final drilling depth (Z1) is reached.

The specified amount can be defined either per machine data or in the parameter screenform. If the parameter is pre-assigned via machine data, it does not appear in the parameter screen.

Please read the machine manufacturer's instructions.

Select key
to call Help display

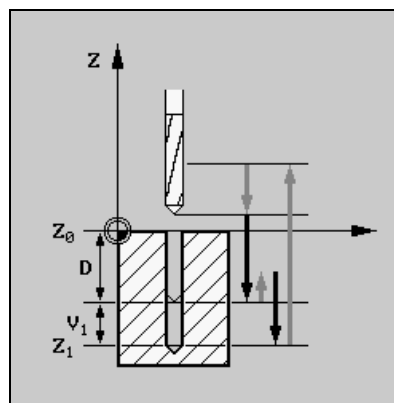

Help display for deep hole drilling with chip breaking

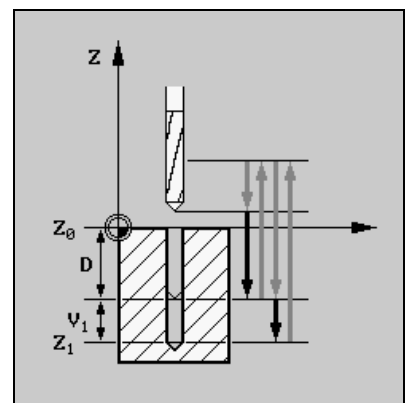

Help display for deep hole drilling with stock removal

3.7 Drilling



Parameters	Description	Unit
T, D, F, S, V	See Section "Program tool, offset value and spindle speed".	
Stock removal	The drill retracts from the workpiece for unclamping.	
"Chip breaking"	The drill is retracted by the specified amount V@ for chip breaking.	
Tip	The final drilling depth (Z1) refers to the drill tip	
Shank	The final drilling depth (Z1) refers to the drill shank	
Z1	Final drilling depth (incr.)	mm
D	Max. infeed	mm
DF	Percentage for each additional infeed DF=100: Infeed increment remains unchanged DF<100: Infeed increment is reduced in direction of final drilling depth Example application: Last infeed was 4mm; DF is 80 Next infeed = 4 x 80% = 3.2mm Next infeed = 3.2 x 80% = 2.56mm etc.	%
V1	Minimum infeed Parameter V1 is provided only if DF< 100 has been programmed. If the infeed increment becomes minimal, a minimum infeed can be programmed in parameter "V1". V1 < infeed increment: The tool is inserted by the infeed increment. V1 > infeed increment: The tool is inserted by the infeed value programmed under V1.	mm
V2	Specified amount or defined per machine data – for chip breaking only Amount by the which the drill is retracted for chip breaking. V2=0: The tool is not retracted but remains in place for one rotation.	mm
V3	Limit distance – for unclamping only Distance to last infeed depth that the drill approaches at rapid traverse after unclamping. Automatic: The limit distance is calculated by ShopMill.	mm
DT	Dwell time for relief cut	s U

3.7.4 Boring



Function

The tool is moved in rapid traverse to the programmed position, allowing for the return plane and safety clearance. It is then inserted into the workpiece at the feedrate programmed under F until it reaches the programmed depth (Z1). The spindle stops at a specific position there. "Lift off contour" or "Do not lift off contour" can be programmed on expiry of the dwell time.

With retraction, withdrawal distance D and the tool orientation angle α can either be defined via machine data or in the parameter screen. If both parameters are pre-assigned via machine data, they do not appear in the parameter screen.

Please read the machine manufacturer's instructions.

Select with soft keys



Boring

Select key
to call Help display

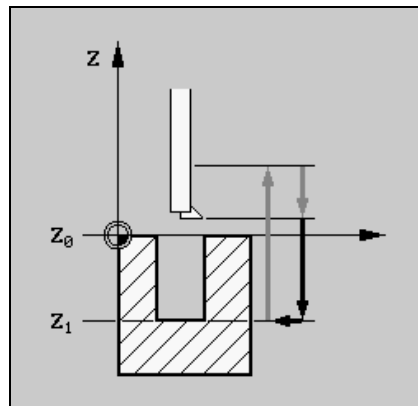

Help display for boring

Parameters	Description	Unit
T, D, F, S, V	See Section "Program tool, offset value and spindle speed".	
Lift off contour	The cutting edge is retracted from the bore edge and then moved back to the return plane.	
Do not lift off contour	The cutting edge is not retracted, but traverses back to the safety clearance in rapid traverse.	
Z1	Depth in relation to Z0 (abs. or incr.)	mm
Z0	Height of workpiece; Z0 is specified in the position pattern ("Positioning" soft key).	mm
DT	Dwell time for relief cut	s U
D	Withdrawal (retract) distance (or defined in machine data) - only for retraction	mm
α	Tool orientation angle (or defined via machine data) - only for retraction	Degrees

3.7.5 Tapping



Function

The tool travels with non-rotating spindle in rapid traverse first to the retraction plane and then to the safety distance. The spindle begins to rotate there and the spindle speed and feedrate are synchronized. Then the tool travels on to the programmed position and is inserted to depth (Z1).

A compensating chuck is not required.

The spindle speed can be controlled by the spindle override during tapping. The feed override is inoperative during this process.

Select with soft keys



Spindle

Tapping

Select key
to call Help display

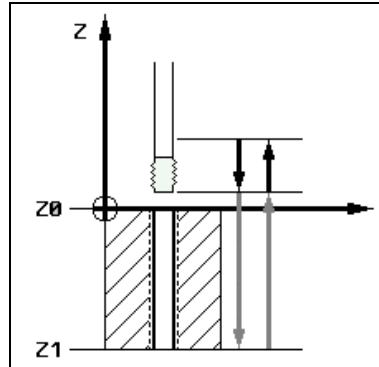

Help display for tapping

Parameters	Description	Unit
T, D, F, S, V	See Section "Program tool, offset value and spindle speed".	
P	Pitch The pitch is determined by the tool used. MODULE: Typical in worm gears that grip the toothed wheel. Turns/": Typical in pipe thread for example. When you enter in turns/", enter the whole number before the decimal point in the first parameter field and the number after the decimal point as a fraction in the second and third fields. For example, enter 13.5 turns/" in the following way: P 13 1/ 2 Thrds/"	mm/rev in/rev MODULE Turns/"
Z1	Tapping depth (abs. or incr.)	mm
Z0	Height of workpiece; Z0 is specified in the position pattern ("Positioning" soft key).	mm

3.7.6 Thread cutting



Function

You can use a form cutter to machine any type of right-hand or left-hand thread.

Threads can be machined as right-hand or left-hand threads and from top to bottom or vice versa.

Select with soft keys

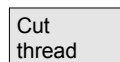
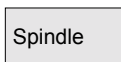

Inside thread

Sequence of operations:

- Position on thread center point on return plane in rapid traverse
- Infeed at rapid traverse to reference plane shifted forward by amount corresponding to safety clearance
- Approach along an approach circle calculated in the control at programmed feedrate
- Approach motion to thread diameter on circular path
- Cut thread along a spiral path in clockwise or counter-clockwise direction (depending on whether it is left-hand or right-hand thread)
- Exit motion along a circular path in the same rotational direction at programmed feedrate
- Retract to thread center point and then to return plane in rapid traverse

Note that the tool must not exceed the following value when milling an inside thread:

Mill diameter < (nominal diameter \varnothing – 2 * thread depth K)



Outside thread

Sequence of operations:

- Position on starting point in return plane at rapid traverse
- Infeed at rapid traverse to reference plane shifted forward by amount corresponding to safety clearance
- Approach along an approach circle calculated in the control at programmed feedrate
- Approach motion to thread diameter on circular path
- Cut thread along a spiral path in clockwise or counter-clockwise direction (depending on whether it is left-hand or right-hand thread)
- Exit motion along a circular path in opposite rotational direction at programmed feedrate
- Retract to return plane in rapid traverse



Select key
to call Help display

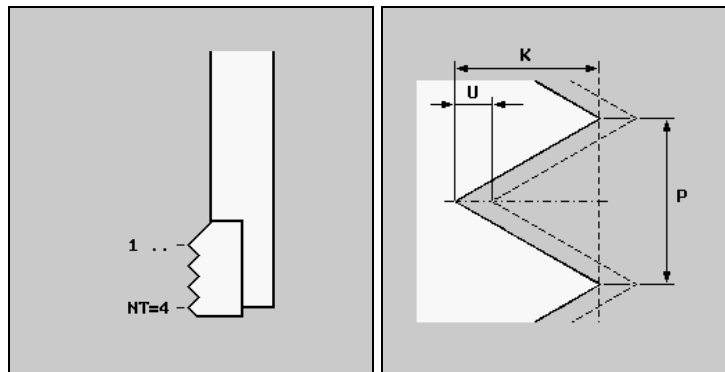
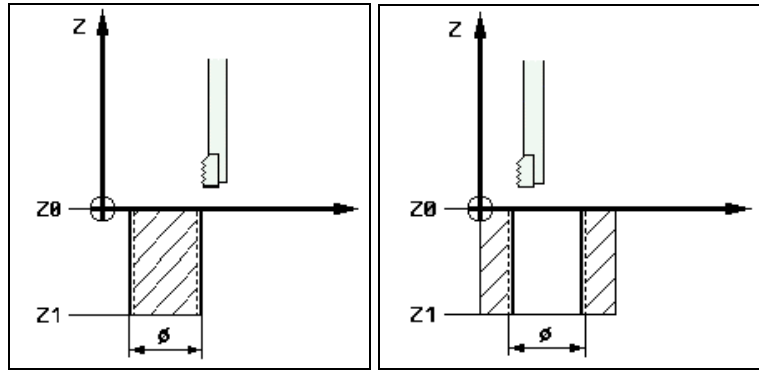

Help displays for thread cutting



Parameters	Description	Unit
Machining type	<input checked="" type="checkbox"/> Roughing Thread cutting up to programmed finishing allowance (U) <input type="checkbox"/> <input type="checkbox"/> <input type="checkbox"/> <input type="checkbox"/> Finishing	
Direction	Depending on the rotational direction of the spindle, a change in direction also changes the machining direction (climb/conventional). Z0 to Z1: Machining begins on workpiece surface Z0. Z1 to Z0: The machining starts at thread depth, e.g. for blind hole tapping	
Inside thr.	An inside thread is cut.	
Outside thr.	An outside thread is cut.	
Left thr.	A left-hand thread is cut.	
Right thr.	A right-hand thread is cut.	
NT	Number of teeth in a milling insert. Single or multiple toothed milling inserts can be used. The cutting teeth are entered in parameter NT. The necessary motions are executed internally by the cycle in such a manner that the tip of the bottom tooth on the milling insert corresponds to the programmed end position when the thread end position is reached. Depending on the cutting edge geometry of the milling insert, the retraction path must be taken into account at the base of the workpiece.	
Z1	Thread length	mm
Z0	Height of workpiece; Z0 is specified in the position pattern ("Positioning" soft key).	mm
∅	Nominal thread diameter, example: Nominal diameter of M12 = 12mm	mm
P	Pitch If the milling insert has several teeth, the pitch will be dependent on the tool used. When you enter the thread pitch in turns/" , enter the whole number before the decimal point in the first parameter field and the number after the decimal point as a	mm/rev inch/rev MODULE Turns/"

	fraction in the second and third fields. For example, enter 13.5 turns/" in the following way: P 13 1/ 2 Thrds/"	
K	Thread depth	mm
DXY	Infeed per cut Alternatively, you can specify the plane infeed as a %, as a ratio --> plane infeed (mm) to milling cutter diameter (mm).	mm %
U	Finishing allowance	mm
$\alpha 0$	Starting angle	Degrees



Programming example for thread cutting

Cut circular pocket in a solid blank and cut a thread.

The milling tool cannot cut across center. The circular pocket will therefore have to be predrilled with a $\varnothing 22$ mm drill. The milling tool can then be inserted centrally.

Using position patterns, the positions of the above-mentioned cycles can be programmed (see Section "Using position patterns in milling").

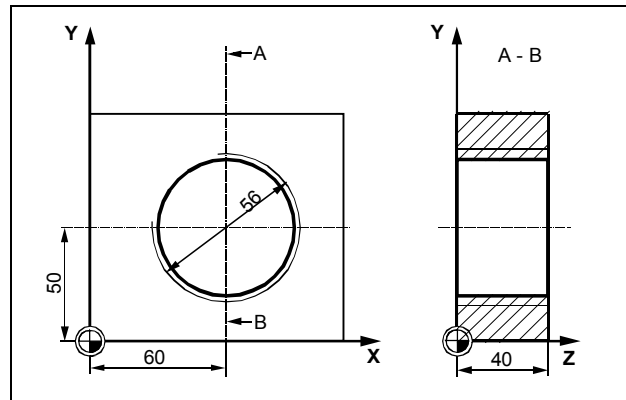

Workshop drawing of circular pocket with thread

	N10 CENTERING	T=center F250/min S900rev. $\varnothing 5$
	N15 DRILL	T=drill122 F80/min S400rev. Z1=42inc
	N20 Circ. pocket	T=12 F500/min S600rev. Z1=40inc $\varnothing 50$
	N25 Inside thread	T=thread56 F100/min S400rev. Z1=40 $\varnothing 56$
	N30 001: Positions	Z0=0 X0=60 Y0=50

Extract from machining plan; cut a circular pocket with thread

3.7.7 Drill and thread milling



Function

You can use a drill and thread milling cutter to manufacture an internal thread with a specific depth and pitch in one operation. This means that you can use the same tool for drilling and thread milling, a change of tool is superfluous.

The thread can be machined as a right- or left-hand thread.

Sequence of operations:

- The tool travels at rapid traverse to the safety distance.
- If pre-drilling is required, the tool travels at a reduced drilling feedrate to the pre-drilling depth defined in a machine data.

Please read the machine manufacturer's instructions.

- The tool drills with drill feedrate F_1 to the first drilling depth D . If the final drilling depth is not reached, the tool will travel back to the workpiece surface in rapid traverse for stock removal. Then the tool will travel at rapid traverse to a position 1mm above the drilling depth previously achieved - allowing it to continue drilling at drill feedrate F_1 at the next infeed.
- If another feedrate F_R is required for through-boring, the residual drilling depth Z_R is drilled with this feedrate.
- If required, the tool travels back to the workpiece surface for stock removal before thread milling at rapid traverse.
- The tool travels directly to the starting position for thread milling.
- The thread milling is carried out (climb milling, conventional milling or conventional milling + climb milling) with milling feedrate F_2 . The thread milling acceleration path and deceleration path is traversed in a semicircle with concurrent infeed in the tool axis.

Select with soft keys

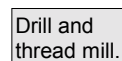
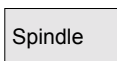

Select key
to call Help display

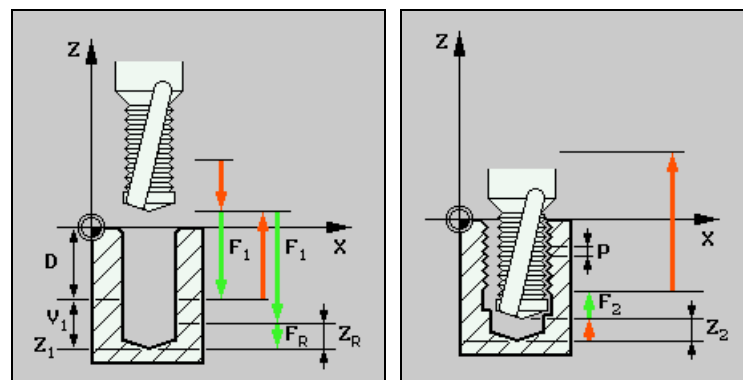

Displays for drill and thread milling cutter



Parameters	Description	Unit
T, D, S, V	See Section "Program tool, offset value and spindle speed".	
F1	Drilling feedrate	mm/min mm/rev
Z1	Drilling depth	mm
D	Maximum infeed	mm
DF	Percentage for each additional infeed increment DF=100: Infeed increment remains unchanged DF<100: Infeed increment is reduced in direction of final drilling depth Z1 Example: Last infeed 4mm; DF 80% Next infeed = 4 x 80% = 3.2mm Infeed after next infeed = 3.2 x 80% = 2.56mm etc.	%
V1	Minimum infeed Parameter V1 is provided only if DF<100 has been programmed. If the infeed increment becomes minimal, a minimum infeed can be programmed in parameter "V1". V1 < infeed increment: The tool is inserted by the infeed increment. V1 > infeed increment: The tool is inserted by the infeed value programmed under V1.	mm
Pre-drilling	When drilling, start initially with a reduced feedrate. The reduced drilling feedrate results as follows: Drilling feedrate F1 < 0.15mm/rev: Pre-drilling feedrate = 30% of F1 Pre-drilling feedrate F1 ≥ 0.15mm/rev: Pre-drilling feedrate = 0.1mm/rev	
Through-drilling	When drilling the residual drilling depth ZR drill with feedrate FR.	
ZR	Residual drilling depth (for through-drilling only)	mm
FR	Feedrate through-drilling (for through-drilling only)	mm/min mm/rev
Stock removal	Return to workpiece surface for stock removal before thread milling.	
Thread	Right-hand thread Left-hand thread	
F2	Milling feed	mm/min mm/tooth
P	Pitch When you enter the thread pitch in turns/", enter the whole number before the decimal point in the first parameter field and the number after the decimal point as a fractional number in the second and third fields. For example, enter 13.5 turns/" in the following way: P 13 1/ 2 Thrds/"	in/rev Turns/"
Z2	Retraction before thread milling Z2 is for defining the thread depth in the direction of the tool axis. Z2 is relative to the tool tip.	mm
∅	Nominal thread diameter	mm
Machining direction	Climb milling: Mill thread in one cycle. Conventional milling: Mill thread in one cycle. Conventional milling + climb milling: Mill thread in two cycles: rough cutting is performed by conventional milling with defined allowances, then finish cutting is performed by climb milling with milling feedrate FS.	
FS	Milling feed finish cutting (for conventional milling + climb milling only)	mm/min mm/tooth

3.7.8 Position on freely programmable positions and position patterns



Function

After you have programmed the machining technologies, you must program the positions. ShopMill offers a variety of positioning patterns, i.e.

- Freely programmable positions
- Position on a line or matrix
- Position on a full or pitch circle

You can program any number of these position patterns one after the other. They are traversed in the order in which you program them.

The programmed technologies and subsequently programmed positions are automatically chained by the control.

Machining sequence and tool travel path

The first tool in the program traverses all programmed positions, e.g. center all positions. The second tool in the program then machines all programmed positions, etc. This process is repeated until every programmed drilling operation has been performed at every programmed position.

Inside a position pattern or on the approach from one position pattern to the next, the tool is retracted to safety clearance in the case of optimized retraction, or otherwise to the return plane (see also Section "Create new program; define a blank"). The new position is then approached in rapid traverse.

If the position pattern consists of only one position, the tool is retracted to the return plane after machining.

Select with soft keys

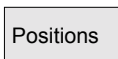

3.7.9 Freely programmable positions



Function

This pattern allows you to program positions freely, i.e. rectangular or polar, in the X/Y plane. Individual positions are approached in the order in which you program them. Press soft key "Delete all" to delete all positions programmed in X/Y.

Select with soft keys

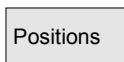

Select key  to call Help display

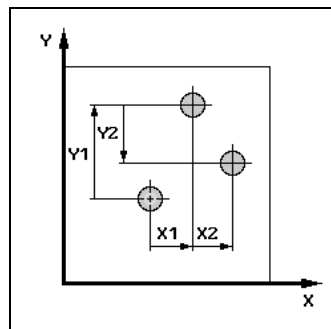

Help display for "Freely programmable positions, rectangular"

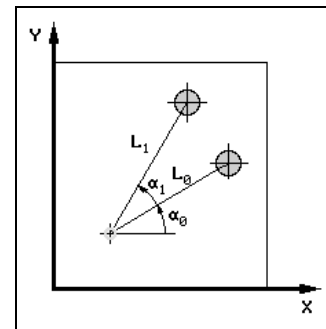

Help display for "Freely programmable positions, polar"



Parameters	Description	Unit
Rectangular/ polar	Programming with rectangular or polar dimensions.	
Z0	Height of workpiece (abs. or incr.)	mm
X0	1st Position of the hole in X (abs. or incr.)	mm
Y0	1st Position of the hole in Y (abs. or incr.)	mm
Rectangular: X1 ... X8 Y1 ... Y8	Other positions in the X axis (abs. or incr.) Other positions in the Y axis (abs. or incr.) If you want to program further positions, store the ones you have already programmed and then open the parameter input form again by pressing soft key "Any positions".	mm mm
Polar: L1 ... L7 α_1 ... α_7	Position distance (abs.) Angle of rotation of line in relation to the X axis. Positive angle: Line is rotated in CCW direction. Negative angle: Line is rotated in CW direction. If you want to program further positions, store the ones you have already programmed and then open the parameter input form again by pressing soft key "Any positions".	mm Degrees

3.7.10 Line position pattern



Function

You can use this function to program any number of positions spaced at the same distance along a line.

Select with soft keys



Positions



Position the cursor in the "Line/matrix" field. You can toggle between Matrix and Line by means of soft key "Alternat.".

Select key
to call Help display

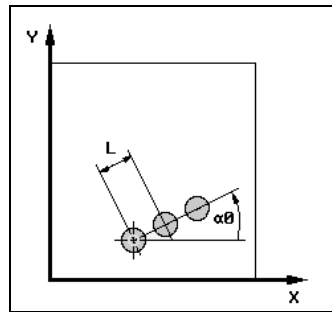

Help display for "Line"

Parameters	Description	Unit
Z0	Height of workpiece (abs. or incr.) This position must be programmed absolutely in the first call.	mm
X0	Reference point (first position) This position must be programmed absolutely in the first call.	mm
Y0	Reference point (first position) This position must be programmed absolutely in the first call.	mm
α_0	Angle of rotation of line in relation to the X axis. Positive angle: Line is rotated in CCW direction. Negative angle: Line is rotated in CW direction.	Degrees
L	Position spacing.	mm
N	Number of positions.	



3.7.11 Matrix position pattern



Function

You can use this function to program any number of positions spaced at an equal distance along one or several parallel lines.

Select with soft keys

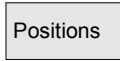

Position the cursor in the "Line/matrix" field. You can toggle between Matrix and Line by means of soft key "Alternat.".

Select key
to call Help display

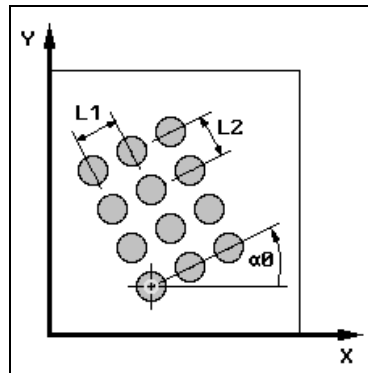

Help display for "Matrix"



Parameters	Description	Unit
Z0	Height of workpiece (abs. or incr.) This position must be programmed absolutely in the first call.	mm
X0	Reference point (first position) This position must be programmed absolutely in the first call.	mm
Y0	Reference point (first position) This position must be programmed absolutely in the first call.	mm
α_0	Angle of rotation of matrix in relation to X axis. Positive angle: Matrix is rotated in CCW direction. Negative angle: Matrix is rotated in CW direction.	Degrees
L1	Position spacing in X direction in relation to an angle of 0 degrees.	mm
L2	Position spacing in Y direction in relation to an angle of 0 degrees.	
N1	Number of positions in X direction in relation to an angle of 0 degrees.	
N2	Number of positions in Y direction in relation to an angle of 0 degrees.	

3.7.12 Full circle position pattern



Function

This function can be used to program drill holes on a circle with a defined radius. The basic angle of rotation (α_0) for the 1st position is relative to the X axis. The control calculates the angle of the next hole as a function of the total number of holes. The angle it calculates is identical for all positions.

The tool can approach the next position along a linear or circular path.

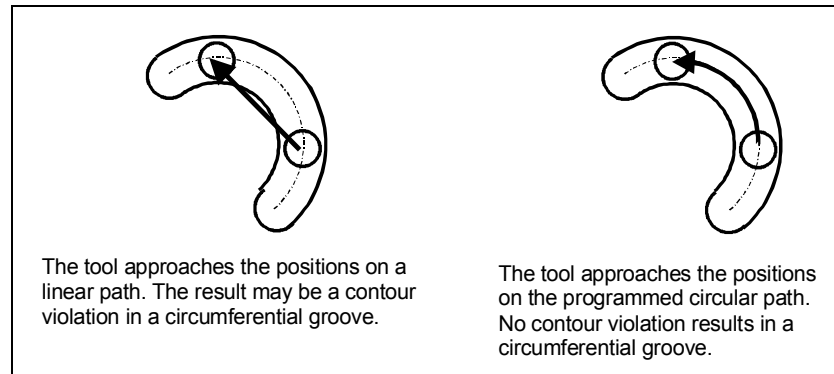

Approach positions on a linear or circular path

Select with soft keys

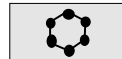
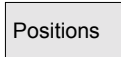

If you position the cursor on the "Full/pitch circle" field, you can toggle between the two options using soft key "Alternat.".

Select key
to call Help display

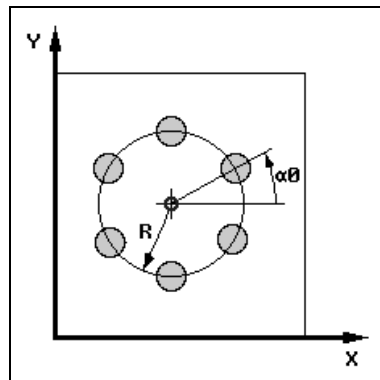

Help display for "Full circle of holes"



Parameters	Description	Unit
Z0	Height of workpiece (abs. or incr.)	mm
X0	X position of full circle center point (abs. or incr.)	mm
Y0	Y position of full circle center point (abs. or incr.)	mm
$\alpha 0$	Basic angle of rotation; angle of 1st hole in relation to X axis. Positive angle: Full circle is rotated in CCW direction. Negative angle: Full circle is rotated in CW direction.	Degrees
R	Radius of full circle	mm
N	Number of positions on full circle	
FP	Feed for positioning on a circular path.	mm/min
Positioning	Linear: Next position is approached linearly at rapid traverse. Circular: Next position is approached at the programmed feedrate (FP) along a circular path.	

3.7.13 Pitch circle position pattern



Function

This function can be used to program holes on a pitch circle with a defined radius.

The tool can approach the next position along a linear or circular path. (please see "Full circle" for detailed description).

Select with soft keys



If you position the cursor on the "Full/pitch circle" field, you can toggle between the two options using soft key "Alternat.".

Select key
to call Help display

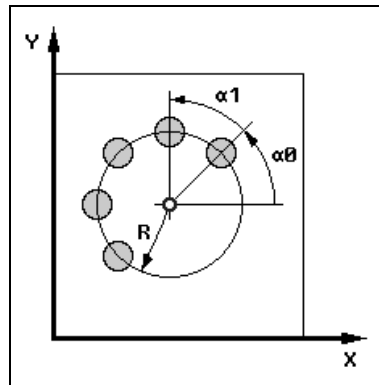

Help display for "Pitch circle"

Parameters	Description	Unit
Z0	Height of workpiece (abs. or incr.)	mm
X0	X position of pitch circle center point (abs. or incr.)	mm
Y0	Y position of pitch circle center point (abs. or incr.)	mm
α_0	Basic angle of rotation; angle of 1st position in relation to X axis. Positive angle: Pitch circle is rotated in CCW direction. Negative angle: Pitch circle is rotated in CW direction.	Degrees
α_1	Advance angle; after the first hole has been drilled, all further positions are approached at this angle. Positive angle: Further positions are rotated in a CCW direction. Negative angle: Further positions are rotated in a CW direction.	Degrees
R	Radius of pitch circle	mm
N	Number of positions (holes) on the pitch circle	
FP	Feed for positioning on a circular path.	mm/min
Positioning	Linear: Next position is approached linearly at rapid traverse. Circular: Next position is approached at the programmed feedrate (FP) along a circular path.	

3.7.14 Obstacle



Select with soft keys



Note

Function

If there is an obstacle between 2 position patterns, it can be crossed. The height of the obstacle can be programmed absolutely or incrementally.

If all positions in the 1st pattern have been machined, the tool axis travels in rapid traverse to a height corresponding to the obstacle height + safety clearance. The new position is approached in rapid traverse at this height. The tool axis then approaches a position corresponding to Z0 of the position pattern + safety clearance.

Obstacles are registered only if they lie between 2 position patterns. If the tool change point and the programmed return plane are positioned below the obstacle, the tool travels to the return plane height and on to the new position without taking the obstacle into account. The obstacle must not be higher than the return plane.



Programming example

Drilling 4 positions with an obstacle in-between.

The holes are first centered and then drilled. When you have programmed the first two positions at X=15, you need to program the obstacle. The remaining positions are then programmed at X=100.

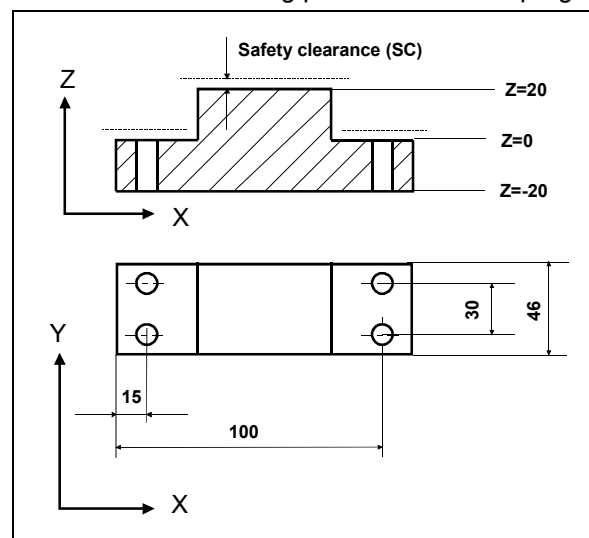

Workshop drawing

	N10 CENTERING	T=4 F250/min S900rev. ø3
	N15 DRILL	T=DRILL10 F80/min S600rev. Z1=22ink
	N20 001: Positions	Z0=0 X0=15 Y0=8 X1=15 Y1=38
	N25 Obstacle	Z20
	N30 002: Positions	Z0=0 X0=100 Y0=8 X1=100 Y1=38

Extract from machining plan for "Obstacle" programming example

3.7.15 Repeat positions



Function

If you want the tool to re-approach positions that you have already programmed, the "Repeat positions" function is a quick and easy solution.

You must specify the number of the position pattern. This is a number assigned automatically by ShopMill. You will find it inserted after the block number in the machining plan.

	N10	Longit. slot	▽	T=12 F0.2/Z S600
	N15	001: Hole full cir.	Z0=0 X0=50 Y0=50 R32 N6	

↑
Position pattern number

Extract from machining plan, position pattern number=001

Select with soft keys

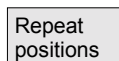

After you have entered the position pattern number, e.g. 1, press soft key "Accept". The position pattern you have selected is then approached again.

	N15	Longit. slot	▽	T=12 F0.2/Z S600rev.
	N20	001: Hole full cir.	Z0=0 X0=50 Y0=50 R32 N6	
	N25	Centering		T=3 F200/min S900rev. Z1=1inc
	N30	DRILL		T=2 F400/min S500rev. Z1=15inc
	N35	Repeat pos.		001: Hole full cir.

Extract from machining plan; repeat positions in block no. 60

3.7.16 Programming examples for drilling



Drilling at different heights

Machining task: You have already cut a recess in a workpiece. You now want to machine blind and through holes of $\varnothing 12\text{mm}$ on this workpiece with different machining planes.

Programming:

Center the 4 holes

Deep drill the blind holes with stock removal

Deep drill the through holes with chipbreaking

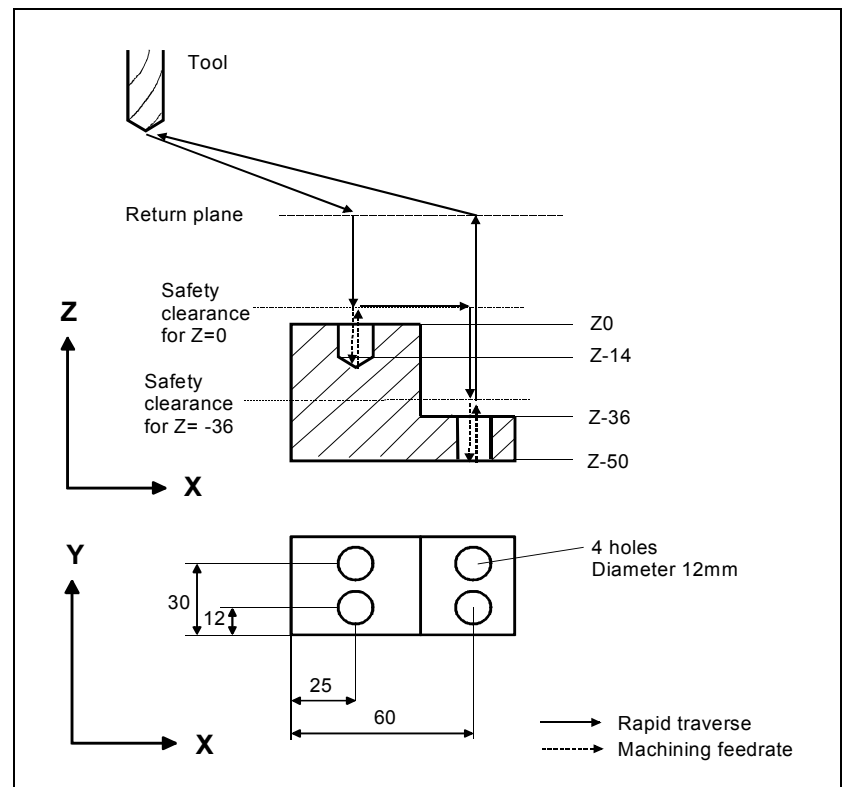

Workshop drawing

	N10 CENTERING	T=center F250/min S900rev. Z1=Zink
	N15 ØØ1: Positions	Z0=0 X0=25 Y0=12 X1=25 Y1=30
	N20 ØØ2: Positions	Z0=-36 X0=60 Y0=12 X1=60 Y1=30
	N25 Deep hole dr.	T=DRILL12 F80/min S600rev. Z1=14ink
	N30 Repeat pos.	ØØ1: Positions
	N35 Deep hole dr.	T=DRILL12 F80/min S600rev. Z1=-52
	N40 Repeat pos.	ØØ2: Positions

Extract from machining plan



Drilling with a counterbore

You want to machine through holes with screw head recesses around a pitch circle on a workpiece.

When you program the counterbore, you must select offset value D2 (see Section "Create tool offset block for tool edge 1/2").

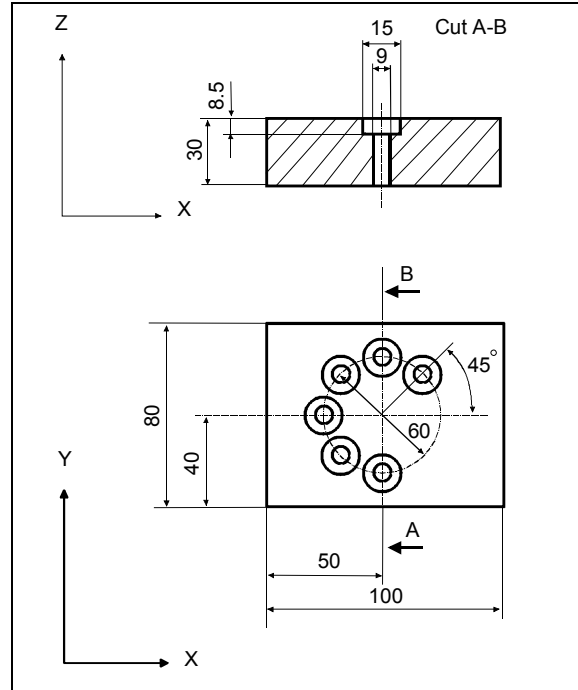

Workshop drawing

	N5 Centering	T=center F200/min S600rev. ø3
	N10 DRILL	T=drill19 F100/min S400rev. Z1=31inc
	N15 DRILL	T=spot_facer F60/min S400rev. Z1=8inc
	N20 ØØ1: Hole pitch cir	Z0=0 X0=50 Y0=40 R30 N6

Extract from machining plan

3.8 Milling

3.8.1 Face milling



Function

You can use this cycle to face mill any workpiece. A rectangular surface is always machined. The rectangle results from corner points 1 and 2 that are pre-assigned with the values of the blank part dimensions from the program header.

The cycle differentiates between roughing and finish cutting.

Roughing:

- Several material removal operations on surface
- Tool turns above the workpiece edge

Finishing:

- First material removal operation on surface
- Tool turns at safety distance in the X/Y plane
- Retraction of mill

Depth infeed always takes place outside the workpiece.

How far the milling tool can travel beyond the workpiece when face milling is defined in a machine data.

Please read the machine manufacturer's instructions.

Select with soft keys



Then select the machining strategy using the vertical soft keys.

Select key
to call Help display

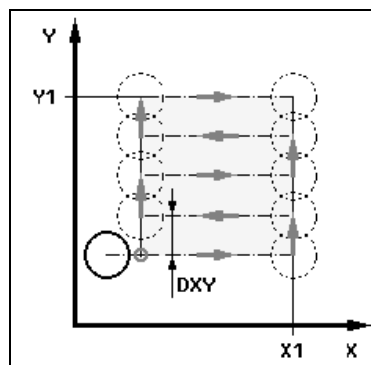

Help display for face milling, alternate machining directions in parallel to X axis

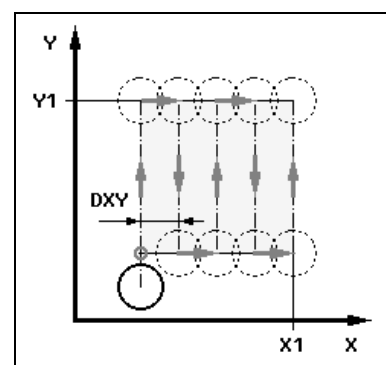

Help display for face milling, alternate machining directions in parallel to Y axis

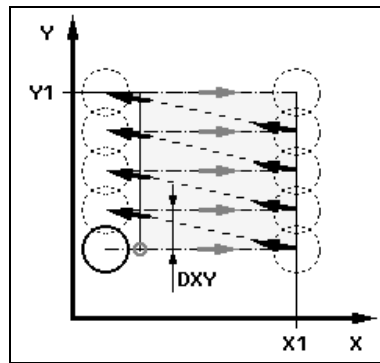

Help display for face milling, one milling direction in parallel to X axis

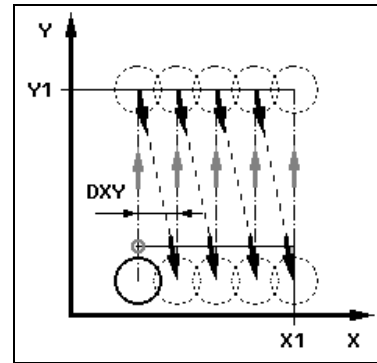

Help display for face milling, one machining direction in parallel to Y axis

Parameters	Description	Unit
Machining type	<input checked="" type="checkbox"/> Roughing: Face milling up to programmed finishing allowance (UZ). <input type="checkbox"/> Finishing: The surface is milled once in the plane. The tool is retracted after every cut.	
X0, Y0	Corner point 1 of surface in X or Y direction (abs. or incr.)	mm
Z0	Height of blank (abs. or incr.)	
X1	Corner point 2 of surface in X direction (abs. or incr.)	mm
Y1	Corner point 2 of surface in Y direction (abs. or incr.)	
Z1	Height of finished part (abs. or incr.)	
DXY	Max. infeed in the XY plane (dependent on mill diameter) Alternatively, you can specify the plane infeed as a %, as a ratio → plane infeed (mm) to milling cutter diameter (mm).	mm %
DZ	Max. infeed in Z direction	mm
UZ	Finishing allowance	mm



- Define corner point 1 of the surface where machining is to begin.
- The same finishing allowance must be entered for both roughing and finishing. The finishing allowance is used to position the tool for retraction.



Programming example
Face milling

You want to cut to a depth of 10mm on a workpiece surface. 8mm must be removed in a rough cut and 2mm in a finish cut. The cutter diameter is 40mm.

Blank dimensions: X0=0, Y0=0, Z0=10, X1=100 abs., Y1=50 abs., Z1=0 abs

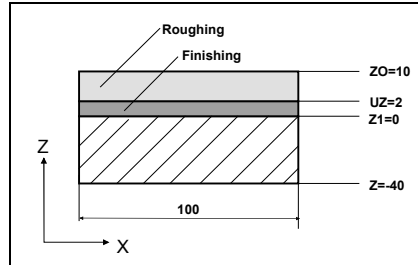

Face milling: Roughing and finishing

Face milling	
T	2 D1
F	600.000 mm/min
S	300 rpm
Machining: ▾	
X0	0.000 abs
Y0	0.000 abs
Z0	10.000 abs
X1	100.000 abs
Y1	50.000 abs
Z1	0.000 abs
DXY	18.000
DZ	5.000
UZ	2.000

Face milling, roughing

Face milling	
T	2 D1
F	300.000 mm/min
S	350 rpm
Machining: ▽▽	
X0	0.000 abs
Y0	0.000 abs
Z0	10.000 abs
X1	100.000 abs
Y1	50.000 abs
Z1	0.000 abs
DXY	18.000
UZ	2.000

Face milling, finishing

⌘	N10	Face milling	▾	T=2 F600/min S300rev. X0=0 Y0=0 Z0=10
⌘	N15	Face milling	▽▽	T=2 F300/min S350rev. X0=0 Y0=0 Z0=10

Extract from machining plan; Roughing and finishing in face milling

3.8.2 Rectangular pocket



If you want to mill a rectangular pocket, use the "Rectangular pocket" function.



The following machining variants are available:

- Mill rectangular pocket from complete material.
- First pre-drill the rectangular pocket in the center if, for example, the mill is not centered (program the blocks pre-drill, circular pocket and position in succession).
- Machine pre-machined rectangular pocket (see "Machining" parameter).

Depending on the dimensions of the rectangular pocket in the workpiece drawing, you can select a corresponding reference point for the rectangular pocket.

Approach/retraction

1. The tool approaches the center of the pocket at rapid traverse at the height of the return plane and infeeds at safety clearance.
2. The pocket is machined according the selected insertion strategy.
3. The tool is retracted at rapid traverse to the safety clearance.

Machining type

You can select machining type when milling the rectangular pocket:

- Roughing
During roughing, the individual planes of the pocket are machined one after the other from the center point until depth Z1 is reached.
- Finishing
During finishing, the edge is always machined first. The edge of the pocket is approached on the quadrant that joins the corner radius. The base is finished from the center during the last infeed.
- Edge finishing
Edge finishing is carried out in the same way as finishing, only the last infeed (base finishing) is omitted.

Select with soft keys

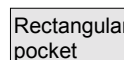
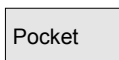

Select key
to call Help display

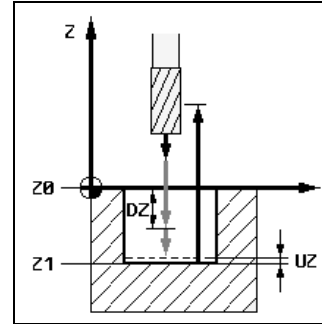
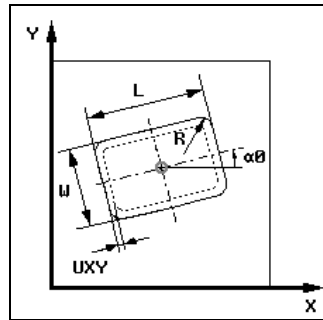

Help display for milling a rectangular pocket



Parameters	Description	Unit
T, F, V	See Section "Program tool, offset value and spindle speed".	
Position of reference point	5 different positions for the reference point can be selected: <ul style="list-style-type: none"> • Pocket center • Lower left-hand corner • Lower right-hand corner • Upper left-hand corner • Upper right-hand corner The reference point (highlighted in yellow) is displayed in the Help screen.	
Machining type	<input checked="" type="checkbox"/> Roughing <input type="checkbox"/> Finishing <input type="checkbox"/> Finishing on edge	
Single pos. Pos. pattern	A rectangular pocket is machined at the programmed position (X0, Y0, Z0). Several rectangular pockets are machined in a position pattern (e.g. full circle, pitch circle, matrix, etc.).	
X0	The positions refer to the reference point: Position in X direction (single position only), abs. or incr.	mm
Y0	Position in Y direction (single position only), abs. or incr.	mm
Z0	Workpiece height (single position only), abs. or incr.	mm
W	Pocket width	mm
L	Pocket length	mm
R	Radius at pocket corners	mm
α_0	Angle of rotation of pocket in relation to X axis.	Degrees
Z1	Depth of pocket in relation to Z0 (abs. or incr.)	mm
DXY	Max. infeed in plane (XY direction) Alternatively, you can specify the plane infeed as a %, as a ratio \rightarrow plane infeed (mm) to milling cutter diameter (mm).	mm %
DZ	Max. depth infeed (Z direction)	mm
UXY	Finishing allowance in plane (pocket edge)	mm
UZ	Finishing allowance in depth (pocket base)	mm
Insertion	You can select several insertion strategies: Helical: Insertion along spiral path The cutter center point traverses along the spiral path determined by the radius and depth per revolution. If the depth for one infeed has been reached, a full circle motion is executed to eliminate the inclined insertion path. Oscillation: Insertion with oscillation along center axis of pocket The cutter center point oscillates along a linear path until it reaches the depth infeed.	

3.8 Milling

	Once it has reached the required depth, it traverses the path again without depth infeed in order to eliminate the inclined insertion path. Center: Insert vertically in center of pocket The tool executes the calculated depth infeed vertically in the center of the pocket. Note: This setting can be used only if the cutter can cut across center or if the pocket has been predrilled.	
EP	Max. insertion pitch (for helical insertion only)	mm/rev
ER	Insertion radius (for helical insertion only)	mm
EW	Insertion angle (for insertion with oscillation only)	Degrees
FZ	Depth infeed rate (for insertion in center only)	mm/min mm/tooth
Solid machining	Complete machining: The pocket must be milled from a solid workpiece (e.g. casting). Remachining: A small pocket or hole has already been machined in the workpiece. This needs to be enlarged in one or several axes. You must program parameters AZ, W1 and L1 for this purpose.	
AZ	Depth of premachined pocket (for remachining only)	mm
W1	Width of premachined pocket (for remachining only)	mm
L1	Length of premachined pocket (for remachining only)	mm



Programming example

You wish to cut a rectangular pocket, starting with a rough cut operation and followed by a finish cut. Since the cutting tool you are using cannot cut across center, the workpiece needs to be predrilled first with a drill of Ø 20mm.

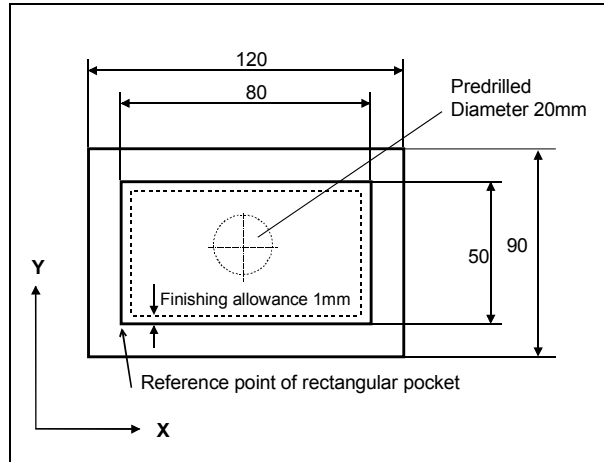

Workpiece drawing of the rectangular pocket

Rectangular pocket

T CUTTER3 D1
 F 300.000 mm/min
 S 500 rpm
 Center
 Machining: ▾
 Position pattern

W 50.000
 L 80.000
 R 1.000
 α0 0.000 °
 Z1 26.000 inc
 DXY 3.000
 DZ 3.000
 UXY 1.000 mm
 UZ 1.000
 Approach: centric
 FZ 0.100 mm/tooth
 Solid mach: Complete mac

Rough cut a rectangular pocket

Rectangular pocket

T CUTTER3 D1
 F 300.000 mm/min
 S 500 rpm
 Center
 Machining: ▽▽▽
 Position pattern

W 50.000
 L 80.000
 R 1.000
 α0 0.000 °
 Z1 26.000 inc
 DXY 3.000
 DZ 3.000
 UXY 1.000 mm
 UZ 1.000
 Approach: centric
 FZ 0.100 mm/tooth

Finish cut a rectangular pocket

N5	Centering	T=center F250/min S900rev. ø5
N10	DRILL	T=drill122 F80/min S400rev. Z1=26inc
N15	Right pocket ▾	T=milling3 F300/min S500rev.
N20	Right pocket ▽▽▽	T=milling2 F200/min S600rev.
N25	Ø01: Positions	Z0=0 X0=60 Y0=45

Extract from machining plan; predrilling and milling a rectangular pocket

3.8.3 Circular pocket



Use the "Circular pocket" function if you want to mill any kind of circular pocket.



The following machining variants are available:

- Mill circular pocket from complete material.
- First pre-drill the circular pocket in the center if, for example, the mill is not centered (program the blocks pre-drill, circular pocket and position in succession).
- Machine pre-machined circular pocket (see "Machining" parameter).

Approach/retraction

1. The tool is moved at rapid traverse to the center point of the pocket at the height of the return plane and at safety clearance.
2. The pocket is machined according the selected insertion strategy.
3. The tool is retracted at rapid traverse to the safety clearance.

Machining type

You can select any machining type when milling the circular pocket:

- Roughing
During roughing, the individual planes of the pocket are machined one after the other from center point until depth Z1 is reached.
- Finishing
During finishing, the edge is always machined first. The edge of the pocket is approached on the quadrant that joins the pocket radius. The base is finished from the center during the last infeed.
- Edge finishing
Edge finishing is carried out in the same way as finishing, only the last infeed (base finishing) is omitted.

Select with soft keys

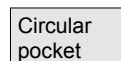

Select key
to call Help display

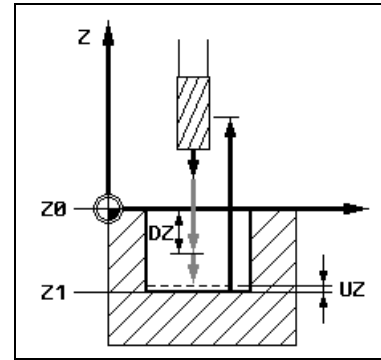
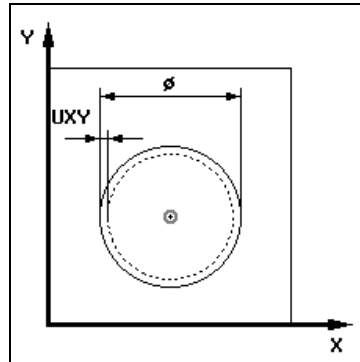

Help display for milling a circular pocket



Parameters	Description	Unit
T, F, V	See Section "Program tool, offset value and spindle speed".	
Machining type	<input type="checkbox"/> Roughing <input type="checkbox"/> Finishing <input type="checkbox"/> Finishing on edge	
Single pos. Pos. pattern	<p>A circular pocket is machined at the programmed position (X0, Y0, Z0).</p> <p>Several circular pockets are machined in a position pattern (e.g. full circle, pitch circle, matrix, etc.).</p>	
X0	The positions refer to the center point of the circular pocket: Position in X direction (single position only), abs. or incr.	mm
Y0	Position in Y direction (single position only), abs. or incr.	mm
Z0	Workpiece height (single position only), abs. or incr.	mm
∅	Diameter of pocket	mm
Z1	Depth of pocket in relation to Z0 (abs. or incr.)	mm
DXY	Max. infeed in plane (XY direction) Alternatively, you can specify the plane infeed as a %, as a ratio → plane infeed (mm) to milling cutter diameter (mm).	mm %
DZ	Max. depth infeed (Z direction)	mm
UXY	Finishing allowance in plane (pocket edge)	mm
UZ	Finishing allowance in depth (pocket base)	mm
Insertion:	<p>You can select several insertion strategies:</p> <p>Helical: Insertion along spiral path The cutter center point traverses along the spiral path determined by the radius and depth per revolution. If the depth for one infeed has been reached, a full circle motion is executed to eliminate the inclined insertion path. Feedrate: Machining feedrate</p> <p>Center: Insert vertically in center of pocket The tool executes the calculated depth infeed vertically in the center of the pocket. Feedrate: Infeed rate as programmed under FZ Note: The vertical insertion into pocket center method can be used only if the tool can cut across center or if the workpiece has been predrilled.</p>	
EP	Max. insertion pitch (for helical insertion only)	mm/rev
ER	Insertion radius (for helical insertion only)	mm

3.8 Milling

FZ	Depth infeed rate (for insertion in center only)	mm/min mm/tooth
Solid machining	<p>Complete machining: The pocket must be milled from a solid workpiece (e.g. casting).</p> <p>Remachining: A small pocket or hole has already been machined in the workpiece. This needs to be enlarged. Parameters AZ, and \varnothing must be programmed.</p>	
AZ	Depth of premachined pocket or hole (for remachining only)	mm
$\varnothing 1$	Diameter of premachined pocket or hole (for remachining only)	mm

3.8.4 Rectangular spigot



Contour approach/retraction

Use the "Rectangular spigot" function if you want to mill various rectangular spigots.

The following forms are available with or without corner radius:

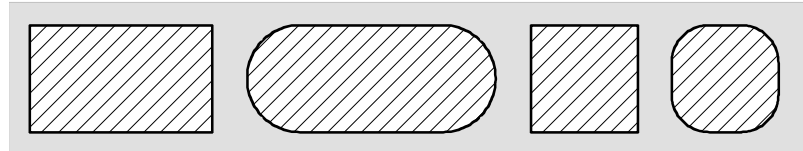

Rectangular spigots

Depending on the dimensions of the rectangular spigot in the workpiece drawing, you can select a corresponding reference point for the rectangular spigot.

In addition to the desired rectangular spigot, you must also define a blank spigot. The blank spigot defines the area outside which there is no material, i.e. rapid traverse can be used there. The blank spigot must not overlap adjacent blank spigots and is placed by ShopMill automatically on the finished spigot in a centered position.

The spigot is only machined with one infeed. If you want to machine with more than one infeeds, you must program the function "Rectangular spigot" several times with a smaller final machining allowance.

1. The tool approaches the starting point at rapid traverse at the height of the return plane and infeeds at safety clearance. The starting point is located on the positive X axis rotated through $\alpha 0$.
2. The tool approaches the spigot contour along the semicircle at machining feedrate. The tool first executes infeed at machining depth and then moves in the plane. The spigot is machined as a function of the programmed machining direction (climb/conventional) in a CW or CCW direction.
3. When the spigot has been circumnavigated once, the tool retracts from the contour along the semicircle and infeeds to the next machining depth.
4. The spigot is approached in a semicircle again and circumnavigated once. This process is repeated until the programmed spigot depth is reached.
5. The tool is retracted at rapid traverse to the safety clearance.

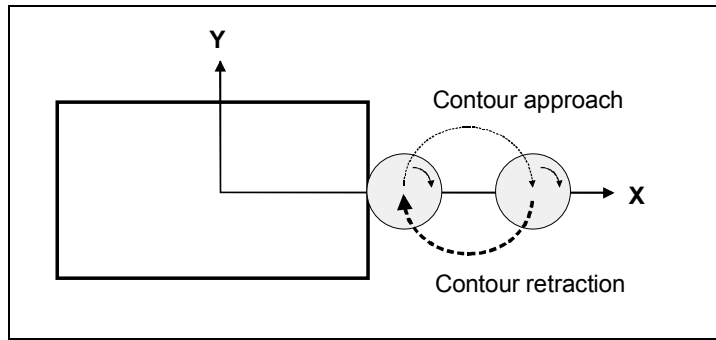

Contour approach/retraction along semi-circle with CW rotating spindle and conventional milling operation

Select with soft keys

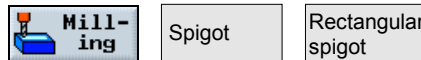

Select key  to call Help display

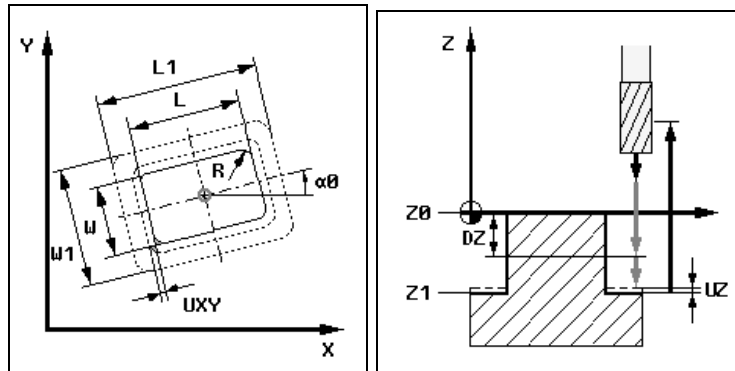

Help displays for milling rectangular spigots



Parameters	Description	Unit
T, F, S, V	See Section "Program tool, offset value and spindle speed".	
Reference point	You can select 5 different reference points: <ul style="list-style-type: none"> • Spigot center • Bottom left • Bottom right • Top left • Top right 	
Machining type	<input checked="" type="checkbox"/> Roughing <input checked="" type="checkbox"/> Finishing	
Single pos. Pos. pattern	A rectangular spigot is machined at the programmed position (X0, Y0, Z0). Several rectangular spigots are machined in a position pattern (e.g. full circle, pitch circle, matrix, etc.).	
X0	The positions refer to the reference point: Position in X direction (single position only), abs. or incr.	mm
Y0	Position in Y direction (single position only), abs. or incr.	mm
Z0	Workpiece height (single position only), abs. or incr.	mm
W	Width of spigot after machining	mm
L	Length of spigot after machining	mm
R	Radius at edges of spigot (corner radius)	mm
$\alpha0$	Angle of rotation	Degrees

Z1	Depth of spigot (abs. or incr.)	mm
DZ	Max. depth infeed (Z direction)	mm
UXY	Finishing allowance in the plane in relation to length (L) and width (W) of the spigot; Smaller spigot dimensions are obtained by calling the cycle again and programming it with a lower finishing allowance.	mm
UZ	Finishing allowance in depth (tool axis)	mm
W1	Width of blank spigot (important for determining approach position!)	mm
L1	Length of blank spigot (important for determining approach position!)	mm

3.8.5 Circular spigot



Use the "Circular spigot" function if you want to mill a circular spigot.



In addition to the desired circular spigot, you must also define a blank spigot. The blank spigot defines the area outside which there is no material, i.e. rapid traverse can be used there. The blank spigot must not overlap adjacent blank spigots and is placed by ShopMill automatically on the finished spigot in a centered position.



The spigot is only machined with one infeed. If you want to machine with more than one infeeds, you must program the function "Circular spigot" several times with a smaller final machining allowance.

Approach/retraction

1. The tool travels at rapid traverse to the starting point at the height of the return plane and infeeds at safety clearance. The starting point is always located on the positive X axis.
2. The tool approaches the spigot contour from the side of semicircle at machining infeed. The tool first executes infeed at machining depth and then moves in the plane. The spigot is machined as a function of the programmed machining direction (climb/conventional) in a CW or CCW direction.
3. When the spigot has been circumnavigated once, the tool exits the contour along a semi-circle in the plane and then infeeds to the next machining depth.
4. The contour is then approached again in a semi-circle and the spigot traversed once. This process is repeated until the programmed spigot depth is reached.
5. The tool is retracted at rapid traverse to the safety clearance.

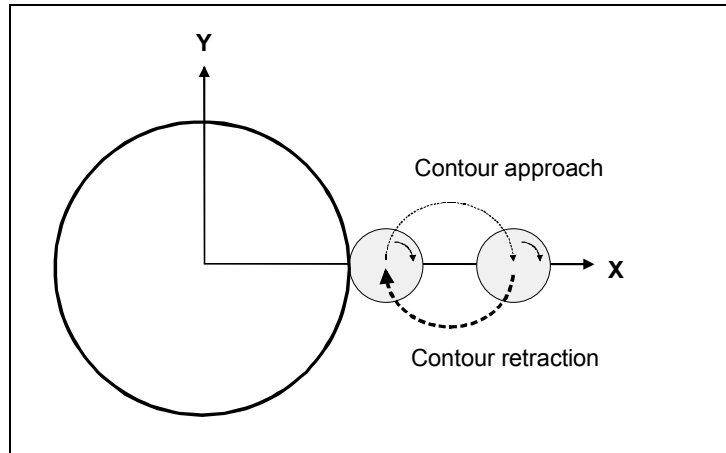

Contour approach/retraction along semi-circle with CW rotating spindle and conventional milling operation

Select with soft keys



Select key to call Help display

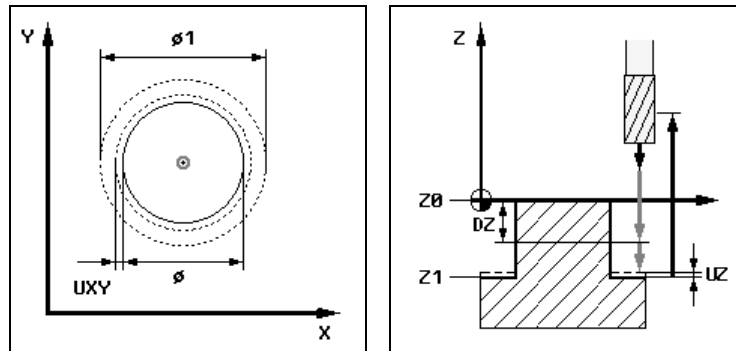

Help display for milling a circular spigot



Parameters	Description	Unit
T, F, S, V	See Section "Program tool, offset value and spindle speed".	
Machining type	<input type="checkbox"/> Roughing <input checked="" type="checkbox"/> Finishing	
Single pos. Pos. pattern	A circular spigot is machined at the programmed position (X0, Y0, Z0). Several circular spigots are machined in a position pattern (e.g. full circle, matrix, line).	
X0	The positions refer to the reference point: Position in X direction (single position only), abs. or incr.	mm
Y0	Position in Y direction (single position only), abs. or incr.	mm
Z0	Workpiece height (single position only), abs. or incr.	mm
ϕ	Diameter of spigot after machining	mm
Z1	Depth of spigot (abs. or incr.)	mm

DZ	Max. depth infeed (Z direction)	mm
UXY	Finishing allowance in plane (spigot diameter)	mm
UZ	Finishing allowance in depth (spigot base)	mm
Ø1	Diameter of blank spigot (important for determining approach position)	mm

3.8.6 Mill longitudinal slot



Use the "Longitudinal slot" function if you want to mill any kind of longitudinal slot.



The following machining variants are available:

- Mill longitudinal slot from complete material.
- Predrill longitudinal slot, for example, when where you are using a cutter that cannot cut across center (program the program blocks Predrill, Rectangular pocket and Position one after the other).

Depending on the dimensions of the longitudinal slot in the workpiece drawing, you can select a corresponding reference point for the longitudinal slot.

Approach/retraction

1. The tool moves at rapid traverse on the return plane and infeeds at safety clearance.
2. The slot is then machined according the selected insertion strategy.
3. The tool is retracted at rapid traverse to the safety clearance.

Machining type

You can select any machining type for milling the longitudinal slot:

- Roughing
During roughing, the individual planes of the slot are machined one after the other until depth Z1 is reached.
- Finishing
The edge is always machined first when finishing. The edge of the slot is thereby approached on the quadrant which joins the corner radius. The base is finished from the center during the last infeed.
- Edge finishing
Edge finishing is carried out in the same way as finishing, only the last infeed (base finishing) is omitted.

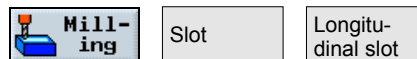
Select with soft keys

Select key  to call Help display

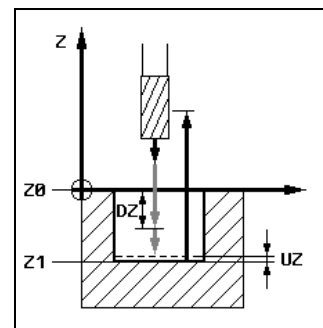
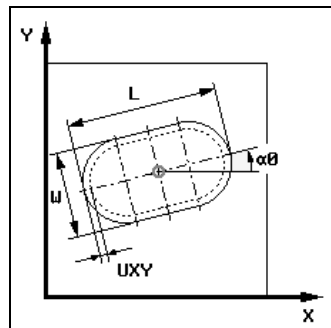

Help display for a longitudinal slot



Parameters	Description	Unit
T, F, S, V	See Section "Program tool, offset value and spindle speed".	
Reference point	The reference point position must be defined: <ul style="list-style-type: none"> Center point of longitudinal slot: Inside left Inside right Left-hand edge Right-hand edge 	
Machining type	<input type="checkbox"/> Roughing <input type="checkbox"/> <input type="checkbox"/> <input type="checkbox"/> Finishing <input type="checkbox"/> <input type="checkbox"/> <input type="checkbox"/> Finishing on edge	
Single pos. Pos. pattern	A longitudinal slot is milled at the programmed position (X0, Y0, Z0). Several longitudinal slots are milled in a position pattern (e.g. full circle, pitch circle, matrix, etc.).	
X0	The positions refer to the reference point: Position in X direction (single position only), abs. or incr.	mm
Y0	Position in Y direction (single position only), abs. or incr.	mm
Z0	Workpiece height (single position only), abs. or incr.	mm
W	Slot width	mm
L	Slot length	mm
$\alpha 0$	Angle of rotation	Degrees
Z1	Slot depth	mm
DXY	Max. infeed in plane (XY direction) Alternatively, you can specify the plane infeed as a %, as a ratio → plane infeed (mm) to milling cutter diameter (mm).	mm %
DZ	Max. depth infeed (Z direction)	mm
UXY	Finishing allowance in plane (slot edge)	mm
UZ	Finishing allowance in depth (slot base)	mm
Insertion	The tool can be inserted vertically over slot center (Mi) or with oscillating motion (Pe): Center=Insert vertically in center of longitudinal slot: The tool is inserted to infeed depth in the pocket center. Note: This setting can be used only if the cutter can cut across center. Oscillation=Insert with oscillation along center axis of longitudinal slot: The cutter center point oscillates along a linear path until it reaches the depth infeed. Once it has reached the required depth, it traverses the path again without depth infeed in order to eliminate the inclined insertion path.	mm
FZ	Depth infeed rate (for insertion in center only)	mm/min mm/tooth
EW	Insertion angle (for oscillation only)	Degrees

3.8.7 Circumferential slot



Use the "Circumferential slot" function if you want mill one or more circumferential slots of the same size on a full or partial circle.



Tool size

Note that the mill for machining the circumferential slot must not be less than a defined minimum size:

- Roughing:
1/2 slot width W – finishing allowance $UXY \leq$ miller diameter
- Finishing:
1/2 slot width $W \leq$ miller diameter
- Finishing on edge
Finishing allowance $UXY \leq$ Milling diameter

Annular slot

If you want to create an annular slot, you must enter the following values for parameters Number N and Aperture angle α_1 :

$$N = 1$$

$$\alpha_1 = 360^\circ$$

Approach/retraction

1. The tool approaches the center of the semicircle at rapid traverse at the end of the slot at the height of the return plane and infeeds at safety clearance.
2. Then, the tool enters the workpiece at machining infeed (taking into consideration the maximum infeed in the Z direction and the finishing allowance). The circumferential slot is machined as a function of the machining direction (climb or conventional) in a CW or CCW direction.
3. When the circumferential slot is completed, the tool approaches the return plane in rapid traverse.
4. The next circumferential slot is approached on a straight line and then machined.
5. The tool is retracted at rapid traverse to the safety clearance.

Machining type

You can select any machining type for milling the circumferential slot:

- **Roughing**
During roughing, the individual planes of the slot are machined one after the other from center point of the semicircle at the end of the slot until depth Z1 is reached.
- **Finishing**
During finishing, the edge is always machined until depth Z1 is reached. The edge of the slot is approached on the quadrant that joins the radius. The last infeed finishes the base from the center point of the semicircle at the end of the slot.
- **Edge finishing**
Edge finishing is carried out in the same way as finishing, only the last infeed (base finishing) is omitted.

Select with soft keys

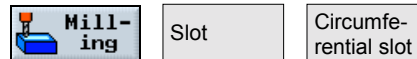

You can toggle between the "Full circle" and "Pitch circle" positioning patterns with soft key "Alternat.".

Select key
to call Help display

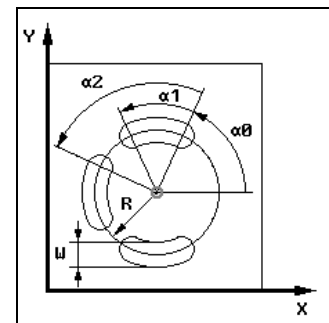
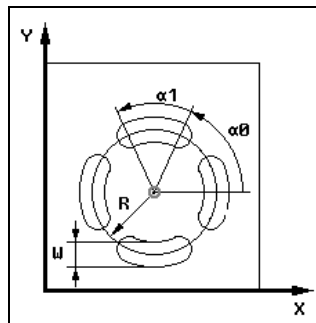

Help display for circumferential slot as full and pitch circle



Parameters	Description	Unit
T, F, S, V	See Section "Program tool, offset value and spindle speed".	
FZ	Infeed depth	mm/min mm/tooth
Machining type	<ul style="list-style-type: none"> ▽ Roughing ▽▽ Finishing ▽▽▽ Finishing on edge 	
Full circle	The slots are positioned around a full circle. The slot spacing is uniform and calculated by the control.	
Pitch circle	The slots are positioned around a pitch circle. The slot spacing can be determined on the basis of angle $\alpha 2$.	
	The positions refer to the center point:	
X0	Position in X direction, abs. or incr.	mm
Y0	Position in Y direction, abs. or incr.	mm
Z0	Workpiece height, abs. or incr.	mm

W	Slot width	mm
R	Radius of circumferential slot	mm
α_0	Angle of rotation in relation to X axis	Degrees
α_1	Arc angle of a slot	Degrees
α_2	Advance angle (for pitch circle only)	Degrees
N	Number of slots	
Z1	Depth of slot in relation to Z0	mm
DZ	Max. depth infeed (Z direction)	mm
UXY	Finishing allowance in XY plane (edge of slot)	mm
Positioning	Linear: Next position is approached linearly at rapid traverse. Circular: Next position is approached at the programmed feedrate FP along a circular path.	
FP	Feed for positioning on a circular path	mm/min

3.8.8 Use of position patterns for milling



Function

If you want to mill a pocket, spigot or longitudinal slot at different positions, you need to program a separate positioning block. When you call the milling cycle, use soft key "Alternat." to select "Pos. pattern" in the "Single position" parameter field. The parameters for single positions X0, Y0 and Z0 then disappear from the display.

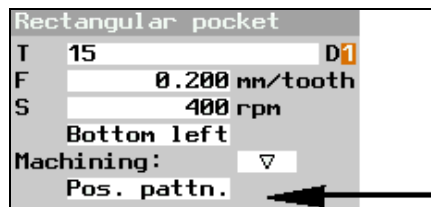

Extract from the parameter form of a rectangular pocket with "Pos. pattern" entry

After you have finished programming the cycle and stored it, you need to program the position pattern.

Select with soft keys

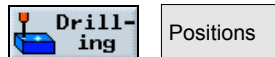

ShopMill automatically chains the milling cycle and the subsequently programmed position pattern.



Programming example 1

You want to mill 12 mutually parallel rectangular pockets at an angle of 15 degrees. Arrangement on matrix: 4 columns, 3 rows.

Blank dimensions: X=115mm, Y=80mm, Z=30mm

Rectangular pocket dimensions: Length 20mm, width 10mm, depth 8mm

Corner radius 1.5mm.

You have selected "Bottom left" as the pocket reference point.

Rectangular pocket		
T	15	D1
F	0.200 mm/tooth	
S	400 rpm	
	Bottom left	
Machining:	▼	
	Pos. pattn.	
W	10.000	
L	20.000	
R	1.500	
α	15.000 °	
Z1	8.000 inc	
DXY	2.000	
DZ	1.000	
UXY	0.000 mm	
UZ	0.000	
Approach:	He	
EP	2.000 mm/rev	
ER	2.000 mm	
Solid nach:	Complete	

Pattern	
Grid	
Z0	0.000 abs
X0	15.000 abs
Y0	5.000 abs
α	15.000 °
L1	25.000
L2	18.000
N1	4
N2	3

Parameter input fields for rectangular pocket and position pattern

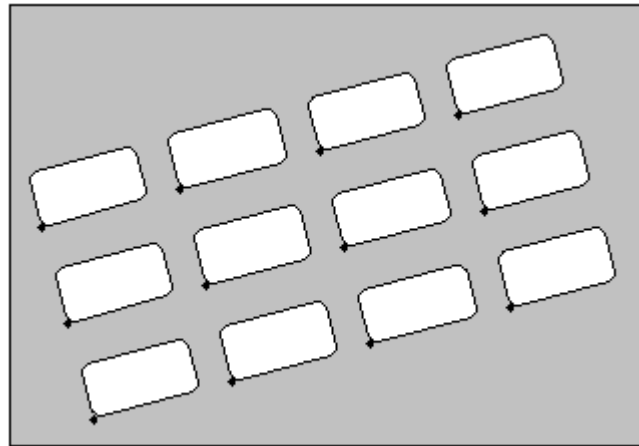

Programming graphic, rectangular pockets on matrix at angle of 15 degrees

	N10	Right pocket	▼	T=15 F0.2/Z S400 rev. Z1=8 inc W10 L20
	N15	001: Hole grid		Z0=0 X0=15 Y0=5 N1=4 N2=3

Extract from machining plan; milling rectangular pockets on a matrix



Programming example 2

You want to rough cut 6 longitudinal slots on a full circle of \varnothing 32mm. The slots are rotated through 30 degrees.

Blank dimensions: X=100mm, Y=100mm, Z=20mm

Slot dimensions: Length 28mm, width 16mm, depth 5mm

You have selected "center point" as the slot reference point.

Longitudinal slot	
T	12 D1
F	0.200 mm/tooth
S	600 rpm
Center	
Machining: ▾	
Pos. pattn.	
W	16.000
L	28.000
α	30.000 °
Z1	5.000 inc
DXY	1.000
DZ	1.000
UXY	0.000 mm
UZ	0.000
Approach: osc.	
EW	20.000 °

Pattern	
Full circle	
Z0	0.000 abs
X0	50.000 abs
Y0	50.000 abs
α	0.000 °
R	32.000
N	6
Positioning: Strai	

Parameter input fields for longitudinal slot and position pattern

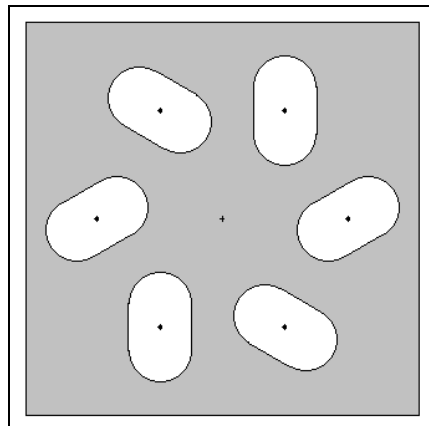

Programming graphic, longitudinal slots at angle of 30 degrees on full circle

	N10 Longit. slot ▾	T=12 F0.2/Z S600rev. Z1=5ink W16 L28
	N15 002: Hole full cir.	Z0=0 X0=50 Y0=50 R32 N6

Extract from machining plan; milling longitudinal slots on a full circle

3.9 Measurements

3.9.1 Measure workpiece zero



If you want to use an electronic measuring probe in a program to determine the workpiece zero, use the "Workpiece zero" function.

For example, if you want to produce several workpieces, an offset may occur between the old and the new workpiece when clamping the next workpiece to the vice. You can measure the workpiece edges to determine the new work zero and save it in a work offset.

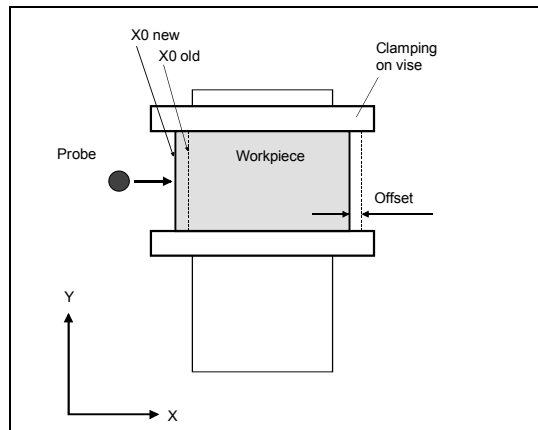

Workpiece clamping with offset in relation to previous clamping

Even if you want to machine several clamped workpieces in parallel, you can determine the zero for each workpiece first.

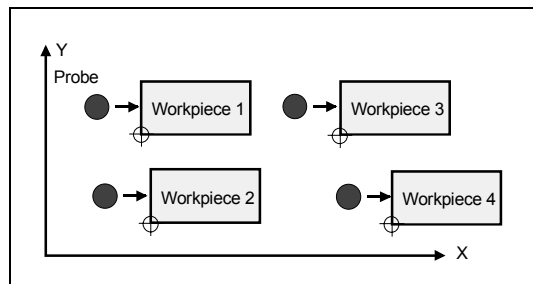

Several clamped workpieces



You can use electronic measuring probes exclusively to determine the workpiece zero within a program. These must be calibrated beforehand (see Section "Calibrate electronic measuring tool"). These measuring probes must always be specified as 3D probe in the tool management.

During automatic measurement, the measuring probe first moves at rapid traverse and then at measuring infeed to the edge of the workpiece and back. The measuring infeed is defined in a machine data.

Please read the machine manufacturer's instructions.

The workpiece radius is considered during calculation of the workpiece zero and is stored in a work offset.

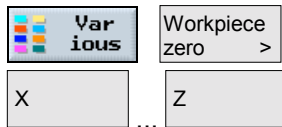

- Insert an electronic measuring probe in the spindle (see Section "Tool, Program offset value and spindle speed").
- Select the "Various" and "Workpiece zero" soft keys.
- Use the soft keys to select in which axis direction you want to approach the workpiece first.
- Specify the values for the individual parameters.
- Press the "Accept" soft key.
- Repeat the process for the other two axes.



Parameters	Description	Unit
T	Tool of type 3D probe	
X	Approach position in X direction (abs.)	mm
Y	Approach position in Y direction (abs.)	mm
Z	Approach position in Z direction (abs.)	mm
Zero off.	Work offset where the workpiece zero is to be saved. <ul style="list-style-type: none"> • Basic work offset • Work offset (the values are saved in the coarse offset and existing values in the fine offset are deleted.) • GUD data (you to scan the measurement result in GUD E_MEAS, e.g. for other calculations (tolerance checks, etc.)). 	
Approach direction	+ : The probe approaches the workpiece in the plus direction - : The probe approaches the workpiece in the minus direction At the approach position in the Z direction, this parameter does not apply as the tool can only approach the workpiece in a negative direction!	
X0, Y0, Z0	Setpoint position of the workpiece edge	mm

3.9.2 Measure tool



Use the "Measure tool" function if you want to check the tool wear while machining the workpiece.

You can only measure the tools within a program using an electronic measuring probe, which you must calibrate the probe first.

You can consider a lateral or longitudinal offset V when measuring. If the maximum length of the tool is not at the utmost outside of the tool the maximum width is not at the utmost bottom of the tool, you can store this difference in the offset.

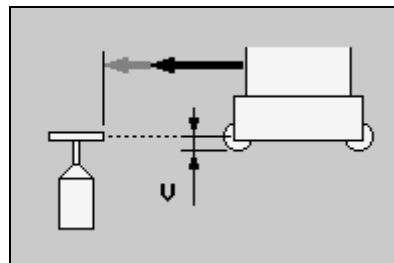

Longitudinal offset

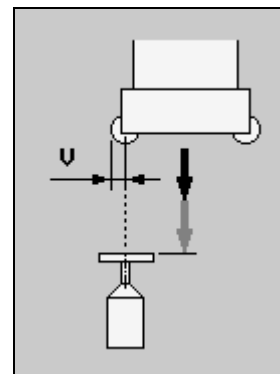

Lateral offset

ShopMill then calculates the tool wear data from the known positions of the toolholder reference point and of the probe and from the tool offset data. The wear values are automatically entered in the wear list and added to any existing values stored there.

If the wear exceeds the maximum permissible value for tool wear ΔL or ΔR , the tool is replaced and disabled against further use. If no replacement tool is available, the machining operation is interrupted.

During the measuring cycle, the tool approaches the measuring probe automatically at measuring infeed and then returns to the initial position.

ShopMill automatically executes the measurement with either a rotating or stationary spindle depending on the tool type and selected measurement method (measure radius/length).

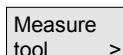

- Move the tool until it is positioned over the approximate center of the measuring surface of the probe (see Section "Straight or circular path motion").
- Press the "Various" and "Measure tool" soft keys.

 Measure length

-or-

 Measure radius

- Use the soft keys to select whether you want to measure the radius or the length of the tools.



Parameters	Description	Unit
T	Tool to be measured	
D	Cutting edge of the tool	
V	Lateral offset (if necessary) – for length measurement only Longitudinal offset (if necessary) – for radius measurement only	mm mm
ΔL	Max. permissible wear value (see tool data sheet supplied by tool manufacturer) – applies only to length measurement	mm
ΔR	Max. permissible wear value (see tool data sheet supplied by tool manufacturer) – applies only to radius measurement	mm

3.9.3 Calibrate the measuring probe



If you want to use a measuring probe to measure your tools, you must first determine the position of the probe on the machine table relative to the machine zero.

You can determine this position either within a program (see below) or during preparation (see Section "Operation" → "Calibrate the measuring probe").



You must use a mill-type calibration tool to calibrate the measuring probe. You must enter the length and radius/diameter of the tool in the tool list beforehand.

Calibration is automatically executed at the measuring feedrate.

The distance measurements between the machine zero and measuring probe are calculated and stored in an internal data area.



- Insert the calibration tool (see Section "Tool, Program offset value and spindle speed").

- Move the calibration tool until it is positioned over the approximate center of the measuring surface of the measuring probe (see Section "Straight or circular path motion").

- Press the soft keys "Various" and "Measure tool".

- Press soft key "Calibrate probe".

- Choose whether you want to calibrate the length or the length and diameter of the probe.

 Various

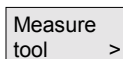
 Measure tool >

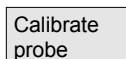
 Calibrate probe

3.10 Miscellaneous functions

3.10.1 Call subroutine



If you need the same machining steps for programming different workpieces, you can define these machining steps as a separate subroutine. You can then call this subroutine in any programs. Thus you no longer need to program the same machining steps several times.

ShopMill does not differentiate between main program and subroutine. This means that you can call a "standard" ShopMill or G code program as subroutine in another ShopMill program. In turn, you can call another subroutine in the subroutine. The maximum nesting depth is 8 subroutines.

You cannot insert subroutines among chained blocks.

If you want to call a ShopMill program as a subroutine, the program must already have been calculated once (load or simulate program in Machine Auto mode). This is not necessary for G code subroutines.

The subroutine must always be stored in the main NC memory. If you want to call a subroutine that is located on another drive, you can use the G code command "EXTCALL".

P	N5 SHOPMILL	
	N10 Face milling	T=CUTTER F...
	N15 Work offset	1 G54
	N45 Execute	"TASCHE_b"
	N20 Work offset	2 G55
	N40 Execute	"TASCHE_b"
	N25 Work offset	3 G56
	N50 Execute	"TASCHE_b"
	N30 Work offset	4 G57
	N55 Execute	"TASCHE_b"
END	Program end	

Call subroutine "Tasche_b"

Call subroutine

Please note that when a subroutine is called, ShopMill evaluates the settings in the program header of the subroutine. These settings remain effective after the subroutine was terminated. If you want to retain the settings from the program header of the main program, delete the settings in the program header of the subroutine.

3.10 Miscellaneous functions

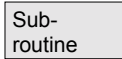

- How to create a ShopMill or G code program that you can call as a subroutine in another program.
- Position the cursor in the machining plan of the main program on the program block after which you want to call the subroutine.
- Press the "Various" and "Subroutine" soft keys.
- Specify the path of the program if the subroutine you want to run is not contained in the same directory as the main program.
- Enter the name of the subroutine you want to insert.
You can specify the file ending (*.mpf or *.spf) if necessary. If you only enter the program name, ShopMill will assign the extension.
- Press the "Accept" soft key.

The subroutine call is inserted in the main program.

3.10.2 Repeat program blocks



If specific steps need to be carried out repeatedly when machining a workpiece, then you only need to program these machining steps once. ShopMill offers a function for repeating program blocks.



The program blocks you want to repeat, must be characterized by a start and end marker. These program blocks can then be called up to 9,999 times within a program. The markers must all be unambiguous, i.e. have different names.

You can also set markers and repeats any time later, but not within chained program blocks.



Further, you can use the same marker as end marker for the preceding program blocks and as start marker for the following program blocks.

P	N5	SHOPMILL	
	N10	begin:	— Start marker
	N15	Right pocket	▽ T=MILL16 F0
	N20	end:	— End marker
	N25	Offset	X30 Y0
	N30	Scaling	add X1.5 Y1.5
	N35	Repetition	begin end — Repeat
END	N40	Program end	

Repeat program blocks



Set marker



Set marker



Repeat



- Press the "Various" and "Set marker" soft keys.
- Specify a name.
- Press the "Accept" soft key.

The start marker is inserted after the current block.

- Specify the program blocks you would like to repeat later.
- Press the "Various" and "Set marker" soft keys.
- Specify a name.
- Press the "Accept" soft key.

The end marker is inserted after the current block.

- Continue programming until the location where the program blocks are to be repeated.
- Select the "Various" and "Repeat" soft keys.
- Specify the name of the start marker and end marker as well as the number of repeats.
- Press the "Accept" soft key.

The marked program blocks are repeated.

3.10.3 Change program settings



All parameters defined in the program header, with the exception of the unit of measurement, can be changed at any location in the program.



The settings in the program header are modal, i.e. they are effective until they are changed.

Define a new blank, e.g. in the ShopMill program, if you want to change the visible cutout during simulation. This is useful for the work offset, coordinate transformation, cylinder peripheral surface transformation and swiveling functions. First program the functions listed above and then define a new blank.

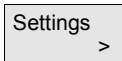

- Select soft keys "Various" and "Settings".
- Enter the parameter of your choice.
For a description of the parameters, please refer to section "Create new program".
- Press the "Accept" soft key.



The new settings for the program take effect.

3.10.4 Call work offsets



You can call work offsets (G54 etc.) from any program. You can use these offsets, e.g., if you want to machine workpieces with different blank part dimensions in one and the same program. The offset then shifts the workpiece zero for the new blank.

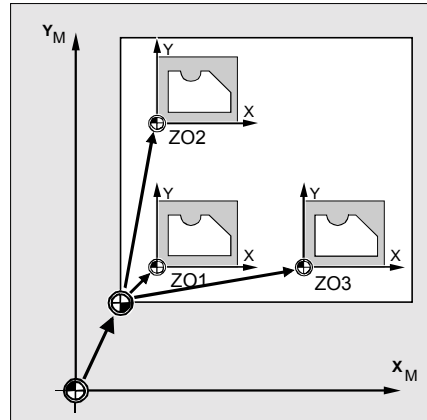

Work offset in X and Y directions



You define the work offsets in the work offset list (see Section "Define work offsets"). You can also see the coordinates of the selected offset.



Transformations >

Work offset >

➤ Press the "Various", "Transformations" and "Work offset" soft keys.

➤ Select one of the work offsets or the basic offset.

-or-

➤ Enter the desired offset directly in the input field.

-or-

➤ Press the "Work offset" soft key.

The work offset list is opened.

-and-

➤ Select a work offset.

-and-

Work offset >

to
program

- Press the "To program" soft key.

The work offset is transferred to the parameter screen.

If you want to deselect the work offset, select the basic offset or enter a zero in the field.



3.10.5 Define coordinate transformation



To facilitate programming, you can transform the coordinate system. Make use of this opportunity, e.g., if you want to rotate the coordinate system.



Coordinate transformations are only valid in the current program. You can define a translation, rotation, scaling or mirroring. You can choose between a new or an additive coordinate transformation. With a new coordinate transformation all previously defined coordinate transformations are deselected. An additive coordinate transformation is effective in addition to the currently selected coordinate transformation.

- Translation

You can program a translation of the zero point for each axis.

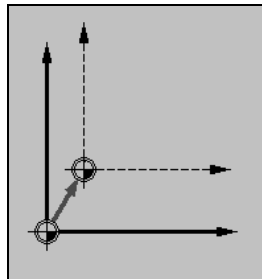

New offset

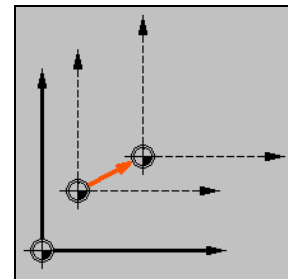

Additive offset

- Rotation

You can rotate every axis around a specific angle. A positive angle corresponds to a counterclockwise rotation.

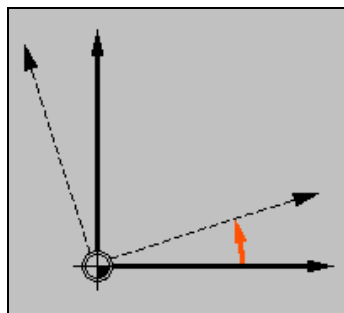

New rotation

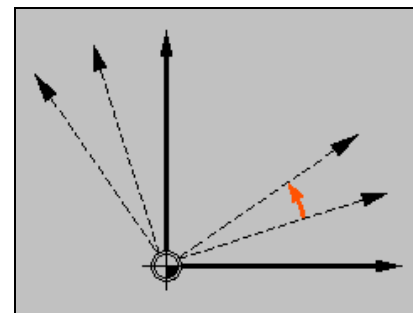

Additive rotation



- **Scaling**

You can specify a scale factor both for the active machining plane and for the tool axis. The programmed coordinates are multiplied by this factor.

Note that the scaling always refers to the zero point of the workpiece. If, for example, you want to increase the size of a pocket whose center point does not coincide with the zero point, then the pocket center point is shifted in the scaling.

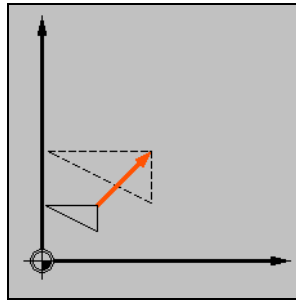

New scaling

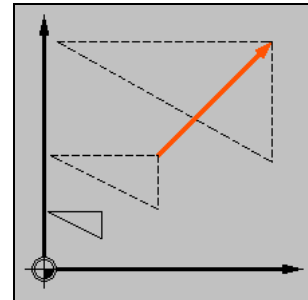

Additive scaling

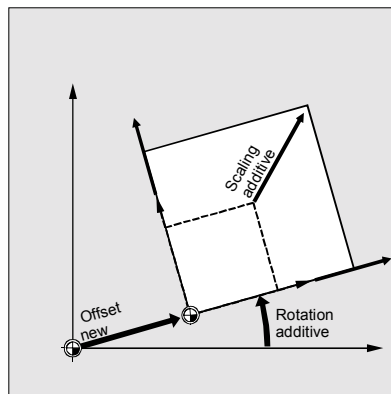

Translation, rotation and scaling

- **Mirroring**

You can also mirror all axes.

Specify the axis you want to mirror.

Note that with mirroring, the travel direction of the cutting tool (conventional/climb) is also mirrored.



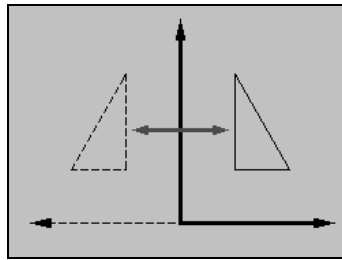

New mirroring

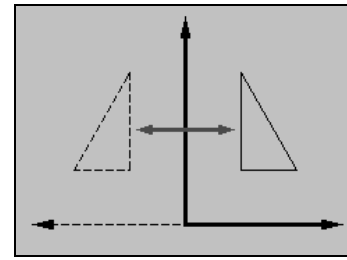

Additive mirroring

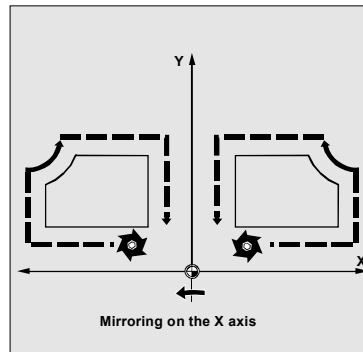

Mirroring the X axis



Various

Transformations >

Offset

>

...

Mirroring

>

- Press the "Various" and "Transformation" soft keys.
- Use the soft keys to select the coordinate transformation.
- Choose whether you want to program a new or an additive coordinate transformation.
- Enter the coordinates of your choice.

3.10.6 Cylinder peripheral surface transformation



Function

Cylinder peripheral surface transformation is required to machine

- longitudinal slots on cylindrical solids,
- cross slots on cylindrical solids,
- any other slot shapes on cylindrical bodies.

The cylinder peripheral surface transformation is a software option.

The shape of the slots is programmed with reference to the developed level cylinder surface area. The slot can be programmed as a line/circle contour, via drilling or milling cycles or with the contour milling function (free contour programming).

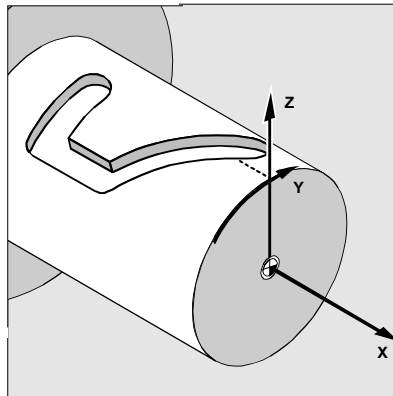

There are two types of cylinder peripheral surface transformation:

- Slot side compensation off
- Slot side compensation on (path milling only)

Slot side compensation OFF

When slot side compensation is deactivated, any type of slot with parallel sides can be machined if the tool diameter equals the slot width.

The slot sides are not parallel if the slot width is larger than the tool diameter.

The slot contour is programmed for machining purposes.

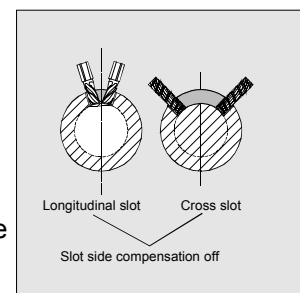

3.10 Miscellaneous functions

Slot side compensation ON When slot side compensation is active, slots with parallel sides are machined even if the slot width is larger than the tool diameter.

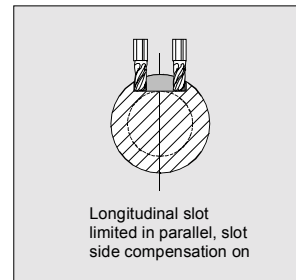

i

The slot contour must not be programmed for machining purposes, but the imaginary center-point path of a bolt inserted in the slot; the bolt must be in contact with all sides of the slot. The slot width is determined by parameter D (see also Section "Example 5: Slot side compensation".)

Programming

The basic programming procedure is as follows:

1. Select work offset for cylinder surface transformation (e.g. offset the zero point on the center point of the cylinder end face)
2. Position the Y axis (Y axis must be positioned prior to cylinder surface transformation because it is defined differently after transformation)
3. Activate cylinder peripheral surface transformation
4. Select work offset for machining on developed cylinder surface (e.g. shift zero point to the zero point on the workpiece drawing)
5. Program machining operation (e.g. enter contour and path milling)
6. Deactivate cylinder peripheral surface transformation

The programmed cylinder peripheral surface transformation is simulated only as a developed peripheral surface.

The work offsets active prior to selection of cylinder surface transformation are no longer active after the function has been deselected.

i

Select with soft keys

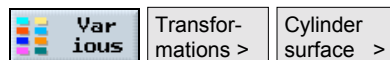



Parameters	Description	Unit
Transformation	Activate/deactivate cylinder peripheral surface transformation (see also example below)	
∅	Cylinder diameter (only when transformation is active)	mm
Slot side comp.	Activate/deactivate slot side compensation (only when transformation is active)	
D	Offset to the programmed path (only when slot side compensation is active)	mm

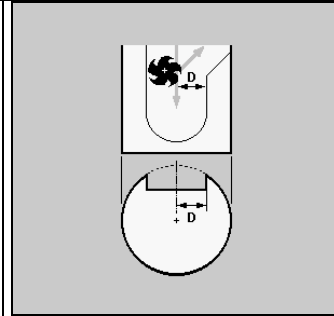

Options for free contour programming

General

For contours (e.g. slots) on a cylinder, lengths in the circumferential direction of the cylinder peripheral surface (e.g. Y axis) are often specified as angles.

Several options are available under the "Mill contour" function in free contour programming for this purpose.

Depending on the selected axis (selection is made via a display machine data), you can enter the length as an angle.

Start point

In the screen form for selecting the start point, you can also activate or deactivate the cylinder peripheral surface transformation function via the "Alternat." soft key. When the function is active, you are offered the diameter \emptyset of the cylinder.

Contour elements

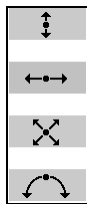

Depending on the axis and the relevant element, angle parameters α , $I\alpha$ or $Y\alpha$, $J\alpha$ are added to the "Horizontal/vertical/diagonal line" and "Arc" when the cylinder peripheral surface transformation function is active.

Notes

- The dimensions of the developed surface are specified in mm in the graphic!
- You must delete the Y value before you can enter an angular value for $Y\alpha$ in the start screen form.



3.10.7 Swiveling



Function

You can use swivel heads or swivel tables to create and/or machine inclined planes.

It is not necessary to program the swivel axes of the machine (A, B, C), since you can program the rotations around the geometry axes (X, Y, Z) of the workpiece coordinate system directly as described in the relevant workpiece drawing.

The rotation of the workpiece coordinate system in the program is then automatically converted to a rotation for the relevant swivel axis of the machine during machining.

You must always swivel the machining plane so that it lies perpendicular to the tool axis for subsequent machining. During machining, the machining plane is permanently set.

When the coordinate system is swiveled, the previously set work offset is automatically converted for the swiveled state.

The basic programming procedure is as follows:

1. Swivel the coordinate system into the plane to be machined.
2. Program the machining operation for the unswiveled plane.
3. Swivel coordinate system back to its original position.



When approaching the programmed machining operation in the swiveled plane, in an unfavorable case the software limit switch could be overtraveled as infeed movement always first takes place in the X/Y plane then in Z direction. To avoid this, before swiveling, e.g. move the tool in the X/Y plane and position it as close as possible to the starting point of the machining operation or define the retraction plane closer to the workpiece.

In a swiveled plane the "Workpiece zero" function is operative but not the "Measure tool" function.

The swiveled coordinates are retained in reset state and even after power ON, i.e. you can still retract from an inclined hole by retracting in Z+ direction.

The following provides an explanation of the most important parameters for swiveling:

Undercut

Before swiveling the axes you can move the tool to a safe retraction position. This position is specified when you set up swiveling in the "Retraction position" parameter.

Please read the machine manufacturer's instructions.



Warning

If you are not going to retract the tool to the safe position, you must ensure that no collisions can occur between tool and workpiece during swiveling.

Swiveling

Select if you only want to swivel the coordinate system or actually want to move the swivel axes too. If you want to perform a machining operation in the swiveled plane, you will need to be able to move the swivel axes.

Swivel variants

The coordinate system can be swiveled either axially or via solid or projection angles. The machine manufacturer determines when setting up the "Swivel" function which swiveling variants are available.

Please read the machine manufacturer's instructions.

- With the axial swiveling variant, the coordinate system is rotated about the individual axes sequentially, which each rotation commencing directly from the previous rotation. The axis sequence is freely selectable.
- With the swiveling variant based on solid angles, the coordinate system is rotated first about the Z axis and then in negative direction about the Y axis. The second rotation commences directly from the first.
- When swiveling via projection angle, rotation is carried out about two axes simultaneously, i.e. you can view two axes at the same time. The third rotation is based on the first two.

You can select any of the axes.

This variant can be used for inclined holes, for example, where the angle in the side views of the workpiece drawing have dimensions.

The side views correspond to non-rotated coordinate system.

The positive direction of rotation for each of the different swivel variants can be found in the Help displays.



Direction

In swivel systems with 2 rotary axes, a particular position can be reached in two different ways, i.e. either via a CW or a CCW rotation. The geometry of the swivel head or table is such that the head or table assumes two different positions depending on the selected direction. This may affect the working area. You can choose between these two different positions in the "Direction" parameter. If one of the two positions cannot be reached for mechanical reasons, the alternative position is automatically selected irrespective of the setting of the "Direction" parameter.

When swiveling is set up, the entries in the "Direction" parameter determine for which rotary axis you can choose between the two settings.

Please read the machine manufacturer's instructions.

3.10 Miscellaneous functions

Fix tool tip

To avoid collisions, you can use the 5-axis transformation (software option) to retain the position of the tool tip. Whether this function is available is determined by the machine manufacturer's settings in the "Follow-up tool" parameter when setting up the "Swivel" function.

Please read the machine manufacturer's instructions.

Select with soft keys

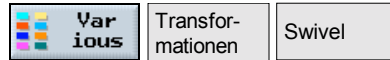

Parameters	Description	Unit
TC	Name of swivel data block 0: Remove inclinable head No entry: No change to set swivel data block	
T	Tool name	
Undercut	Z: Move tool axis to retraction position before swiveling Z, X, Y: Move machining axes to retraction position before swiveling No: Do not move tool to retraction position before swiveling	
Swiveling	Yes: compute and swivel (swivel coordinate system and move swivel axes) No: only compute, don't swivel (only swivel coordinate system, don't move swivel axes)	
Transformation	Transformation (swiveling) additive or new	
X0	Reference point for rotation	mm
Y0	Reference point for rotation	mm
Z0	Reference point for rotation	mm
Swivel variant	Axial swiveling, or swiveling via solid or projection angle	
X	Axis angle (axial swivel)	The sequence of axes can be changed round as required
Y	Axis angle (axial swivel)	
Z	Axis angle (axial swivel)	
α	Angle of rotation in the XY plane about the Z axis (swiveling via solid angle)	Degrees
β	Angle of rotation in space about the Y axis (swiveling via solid angle)	Degrees
X α	Axis angle (swiveling via projection angle)	The sequence of axes can be changed round as required
Y α	Axis angle (swiveling via projection angle)	
Z β	Axis angle (swiveling via projection angle)	
X1	New zero point of rotated surface	mm
Y1	New zero point of rotated surface	mm
Z1	New zero point of rotated surface	mm
Direction	Preferred direction of rotation with 2 alternatives +: Larger angle of axis on the scale of the swivel head/table -: Smaller angle of the axis on the scale of the swivel head/table	

Fix tool tip

Correct: The position of the tool tip is maintained during swiveling.

Do not correct: The position of the tool tip is changes during swiveling.



Other **additive** transformations can be added to the offsets before (X0, Y0, Z0) or after (X1, Y1, Z1) swiveling (see Section "Work offsets").



Programming example

You want to bevel a corner on a cube.

The machining plane is to be the inclined surface, i.e. the machining plane must be swiveled as follows:

- With axial swiveling and swiveling using solid angles, the system of coordinates is rotated first in the XY plane in such a way that the upper edge of the inclined surface of the cube runs parallel to the X axis (rotate 45° about Z axis or $\alpha=45^\circ$). The system of coordinates is then tilted so that the inclined plane of the cube is in the XY plane (rotate -54.736° about Y axis -54.736° or $\beta=54.736^\circ$).
- With the swiveling via projection angles options, the X and Y axes are rotated through 45° so that the inclined plane of the cube is in the XY plane. The Z axis is then rotated through 30° so that the X axis runs through the center point of the inclined surface (zero point of rotated surface).

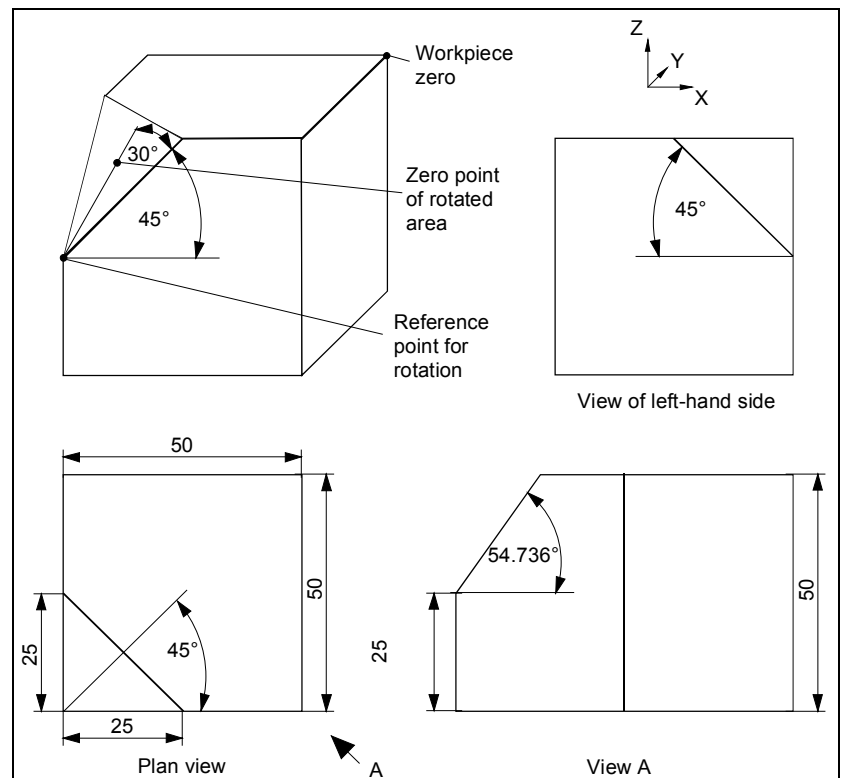

Workpiece machined by an inclinable head

3.10 Miscellaneous functions

Swivel	
T CUTTER	D1
Retract	No
Swivel	Yes
New	
X0	-50.000
Y0	-50.000
Z0	-25.000
axis by ax.	
Z	-45.000 °
Y	54.736 °
X	0.000 °
X1	20.412
Y1	0.000
Z1	0.000
Direction:	-
track	

Swivel (axial)

Swivel	
T CUTTER	D1
Retract	No
Swivel	Yes
New	
X0	-50.000
Y0	-50.000
Z0	-25.000
Solid angle	
α	45.000 °
β	54.736 °
X1	20.412
Y1	0.000
Z1	0.000
Direction:	-
track	

Swivel (solid angle)

Swivel	
T CUTTER	D1
Retract	No
Swivel	Yes
New	
X0	-50.000
Y0	-50.000
Z0	-25.000
Projection angle	
$X\alpha$	45.000 °
$Y\alpha$	-45.000 °
$Z\beta$	30.000 °
X1	20.412
Y1	0.000
Z1	0.000
Direction:	-
track	

Swivel (projection angle)

3.10.8 Miscellaneous functions



You can e.g. position the spindle again between the individual machining steps or activate the coolant or stop machining.



The following functions are available:

- Spindle
Determine direction of spindle rotation or spindle position (see Section "Start, stop and position spindle manually")

- Gear stage
Set gear stage, if machine has gears

Please read the machine manufacturer's instructions.

- Miscellaneous M functions
Machine functions, such as "Close door"; they are additionally provided by the machine manufacturer

Please read the machine manufacturer's instructions.

- Coolant
Activate/deactivate coolant 1/2
- Tool-spec. fct 1 to 4
Select tool-specific functions 1 to 4; they are additionally provided by the machine manufacturer

Please read the machine manufacturer's instructions.

- Dwell time
Set time after which execution on the machine is continued
- Programmed stop
Stop execution on the machine if the "Programmed Stop" soft key is also active (see Section "Program control").
- Stop
Stop execution on the machine



Machine
funct.

- Press the "Straight circle" and "Machine func." soft keys.
- Enter the parameter of your choice.
- Press the "Accept" soft key.



3.11 Insert G code in the ShopMill program



Function

You can program G code blocks within a ShopMill program, as well as insert comments to explain the program.



Explanation

For a detailed description of G code blocks to DIN 66025, please refer to:

References: /PG/, Programming Guide Fundamentals
SINUMERIK 840D/840Di/810D
/PGA/, Programming Guide Advanced
SINUMERIK 840D/840Di/810D

You cannot create G code blocks before the program header, after the program end and within chained program blocks.

ShopMill does not display G code blocks in programming graphics.

If you want to stop workpiece machining at specific locations in the program, program the G code command "M01" in the machining plan at these locations (see Section "Control program run").



P	N5 SHOPMILL
G	N10 ;Program with G-Code
G	N15 F200 S900 T1 D2 M3
G	N20 G0 X100 Y100
G	N25 G1 X150
G	N30 Y120
G	N35 X100
G	N40 Y100
G	N45 G0 X0 Y0
END	N50 Program end

G code in ShopMill program



Operating sequence

- In the machining plan of a ShopMill program, position the cursor on the program block after which you want to insert a G code block.
- Press the "Input" key.
- Specify the desired G code commands or comment.
The comment must always start with a semi-colon (;).

In the machining plan, the newly created G code block is characterized by the "G" preceding the block number.



Notes

Programming with G Code

4.1	Create a G code program	4-244
4.2	Execute G code program	4-247
4.3	G code editor	4-249
4.4	Arithmetic parameters	4-252
4.5	ISO dialects	4-253

4.1 Create a G code program



If you do not want to program with the ShopMill functions, you can also generate a G code program with G code commands in the ShopMill user interface.



You can program a G code command to DIN 66025.

In addition, the parameter screens offer support for measuring and programming contours, drilling and milling cycles. G code is generated from the individual screens; you can compile the code back to the screens again. The measuring cycles and cycle support function must be set up by the machine manufacturer.

Please read the machine manufacturer's instructions.

For a detailed description of G code blocks to DIN 66025 and the cycles and measuring cycles, please refer to:

References: /PG/, Programming Guide Fundamentals
SINUMERIK 840D/840Di/810D
/PGA/, Programming Guide Advanced
SINUMERIK 840D/840Di/810D
/PGZ/, Programming Guide Cycles
SINUMERIK 840D/840Di/810D
/BNM/, User's Guide Measuring Cycles
SINUMERIK 840D/840Di/810D

If you want to obtain further information about specific G code commands or cycle parameters on the PCU 50, you can call up context-sensitive online help.

For a detailed description of the online help, please refer to:

References: /BAD/, Operator's Guide HMI Advanced
SINUMERIK 840D/840Di/810D



Creating a G code program



- Press the "Program" soft key.
- Select the directory where you want to create a new program.
- Press the "New" and "G code program" soft keys.
- Enter a program name.
Program names may be a maximum of 24 characters in length.
You can use any letters, digits or the underscore symbol (_).
ShopMill automatically replaces lower case with upper case.
- Press the "OK" soft key or the "Input" key.

The G code editor is opened.

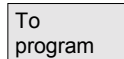
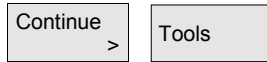
Call tool

- Specify the desired G code commands.
- Press the "Continue" and "Tools" soft keys when you want to select a tool from the tool list.

-and-

- Position the cursor on the tool you want to use for machining.

-and-

- Press the "To program" soft key.

The selected tool is validated in the G code editor.

Text such as the example below is displayed at the current cursor position: T="MILL30"

In contrast to ShopMill programming, the settings made in the tool management do not become active automatically when the tool is called.

This means that you must also program the tool change (M6), the direction of spindle rotation (M3/M4), the spindle speed (S...), the coolant (M7/M8) and any other tool-specific functions required.

Example:

```

...
T= "MILL"           ;call tool
M6                  ;change tool
M7 M3 S2000        ;deactivate coolant and spindle
...
  
```

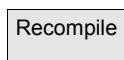
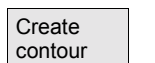
Support

- Use the soft keys to select whether you want support for programming contours, drilling or milling cycles.
- Use the soft key to select the required cycle.
- Enter the parameters.
- Press soft key "OK".

The cycle is transferred to the editor as G code.

- Position the cursor in the G code editor on a cycle if you want to open the associated parameter screen again.

- Press the "Recompile" soft key.

The parameter screen of the selected cycle is displayed.



Edit

If you want to return directly to the G code editor from a parameter screen, press the "Edit" soft key.

Measuring cycle support

Measure
millCalibr.
probe ...

OK

- Switch to the extended horizontal soft key bar.
- Press soft key "Measure mill".
- Use the soft key to select the required measuring cycle.
- Enter the parameters.
- Press soft key "OK".

The measuring cycle is transferred to the editor as G code.

- Position the cursor in the G code editor on a measuring cycle if you want to open the associated parameter screen again.
- Press the "Recompile" soft key.

The parameter screen of the selected measuring cycle is displayed.



Edit

If you want to return directly to the G code editor from a parameter screen, press the "Edit" soft key.

Online help (PCU 50)



- Position the cursor in the G code editor on a G code command or in a cycle support parameter screen on an input field.
- Press the "Help" key.

The relevant help is displayed.

4.2 Execute G code program



When executing a program, the workpiece is machined according to the programming on the machine.

After program start in automatic mode, workpiece machining then runs automatically. You can, however, stop the program at any time and then resume machining again.

To control the programming results in the simplest manner, without traversing the machine axes, you can graphically simulate program execution on the screen.

For more information about simulation, please refer to the section on "Simulation".



The following requirements must be met before executing a program on the machine:

- The NC's measuring system is synchronized with the machine.
- You have a program created in G code.
- The necessary tool offsets and work offsets are entered.
- Any necessary safety interlocks from the machine manufacturer are activated.

When executing a G code program, the same functions are available as for executing a ShopMill program (see Section "Machine workpiece").



Simulate a G code program

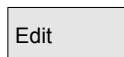
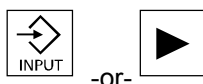

- Press the "Program" soft key or the "Program Manager" key.
- Position the cursor on the required G code program.
- Press the "Input" or "Cursor right" soft key.

The program is opened in the G code editor.

- Press the "Simulation" soft key.

The entire program execution is graphically displayed on the screen.

If you want to return directly to the G code editor from the simulation, press the "Edit" soft key.

Execute a G code program



- Press the "Program" soft key or the "Program Manager" key.

-and-

4.2 Execute G code program



Execute



- Position the cursor on the required G code program.

-and-

- Press soft key "Execute".

-or-

- Press the "Execute" soft key if you are currently in the "Program" operating area.

ShopMill automatically changes to "Machine Auto" operating mode and loads the G code program.

- Press the " Cycle Start" key.

Execution of the G code program is initiated on the machine.

4.3 G code editor



If you want to change the order of the program blocks within a G code program, delete G code or copy from one program to another, use the G code editor.

If you want to change the G code in a program that you are currently executing, you can only change the G code blocks that have not yet been executed. These blocks are specially highlighted.

The G code editor provides the following functions:

- Select
You can select any G code.
- Copy/Insert
You can copy and insert G code both within the same program and between different programs.
- Cut
You can any cut G code and delete it this way. The G code remain in the clipboard so that you can insert it at another location.
- Search/replace
In a G code program you can search for any character string and replace it with another one.
- To beginning/end
In the G code program, you can easily jump to the beginning or the end.
- Numbering
If you insert a new or copied G code block between two existing G code blocks, ShopMill automatically assigns a new block number. This number might be higher than the block number in the next block. You can use the "Renumber" function to number the G code blocks again in ascending order.



Select G code

Mark

If you create or open a G code program, you are automatically in the G code editor.

- Position the cursor on the location in the program where you want to start your selection.
- Press the "Mark" soft key.
- Position the cursor on the location in the program where you want to end your selection.

The G code is selected.

Copy G code



- Select the G code you want to copy.
- Press the "Copy" soft key.

The G code is stored in the clipboard and remains there even if you change to another program.

Insert G code



- Copy the G code you want to insert.
- Press the "Insert" soft key.

The copied G code is inserted from the clipboard in front of the cursor position.

Cut G code



- Select the G code you want to cut.
- Press the "Cut" soft key.

The selected G code is cut and stored in the clipboard.

Search G code



- Select soft key "Search".

A new vertical soft key bar is displayed.

- Specify the character string you want to search for.
- Press soft key "OK".



The G code program is searched in downwards direction for the character string. The search result is marked by the cursor in the editor.



- Press the "Continue search" soft key if you want to continue the search.

The next found character string is displayed.

Find G code and replace

Search

- Select soft key "Search".

A new vertical soft key bar is displayed.

Search/
Replace

- Select soft key "Search/Replace".
- Specify the character string you want to find and the characters you want to insert instead.

OK ✓

- Press soft key "OK".

The G code program is searched in downwards direction for the character string. The search result is marked by the cursor in the editor.

Replace
all

- Press the "Replace all" soft key if you want to replace each occurrence of the character string in the entire G code program.

-or-

Find next

- Press the "Find next" soft key if you want to continue searching without replacing the searched character string.

-or-

Replace

- Press the "Replace" soft key if you want to replace this occurrence of the character string at this location in the G code program.

Jump to start/endContinue
>To
startTo
end

- Press the "Continue" and "To start" or "To end" soft keys.

The beginning or end of the G code program is .

Renumber G code blocksContinue
>Re-
number >

- Press the "Continue" and "Renumber" soft keys.
- Specify the number of the first block and the increment for the block numbers (e.g. 1, 5, 10).
- Press the "Accept" soft key.

Accept ✓

The blocks are renumbered.

You can cancel the numbering again by entering 0 as the block number or incrementation.

4.4 Arithmetic parameters



R variables (arithmetic parameters) are variables that you can use within a G code program.

R variables can be read and written by the G code programs. In the R variable list you can assign a value to R variables that are read.

Input and deletion of R variables can be disabled via the keyswitch.



Display an R variable

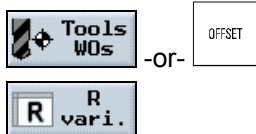

- Press the "Tools WOs" or "Offset" key.

- Press the "R variable" soft key.

This opens the R variable list.

Find an R variable

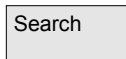

- Select soft key "Search".
- Enter the parameter number you want to find.
- Press the "Accept" soft key.



The parameter you are looking for is displayed.

Edit an R variable

- Position the cursor on the input field of the parameter you want to modify.
- Specify the new value.

The new value of the parameter becomes immediately effective.

Delete an R variable



- Position the cursor on the input field of the parameter whose value you want to delete.
- Press the "Backspace" key.

This deletes the value of the parameter.

4.5 ISO dialects



Read in program

ISO dialect0 M programs (Fanuc0 milling) can also be executed under ShopMill. These are read in and out via the RS-232 interface.

ISO dialect0 M programs are not programs that were created with the SIEMENS G code. See the section 4.1 Create a G code program.

Execute a program

An ISO dialect0 M program is read in by the same method as a ShopMill program.

ISO dialect0 M programs which you read in are stored as main programs in the ShopMill directory.

Before you can execute an ISO dialect0 M program, you must make the following settings:

1. A tool offset data set (geometry and wear data) must be assigned to every H number in the ISO dialect0 M program.
Add the tool geometry data in column "H" of the tool list with the appropriate H number. Each data set must have a unique H number; only replacement tools may have the same H number as another set.
2. Each ISO dialect0 M program must be preceded by command "G291". Command "G290" marks a return to the Siemens program.



In ISO dialect0 M programs, the tool cutting edge number is not shortened to D but to E.

You can display specific ISO dialect G functions by pressing the "G functions" soft key.

Read out program

An ISO dialect0 M program is read out by the same method as a ShopMill program.

Select punched tape/ISO format as the output format.



You can view the assignments between Siemens work offsets and ISO dialect0 M work offsets in a table.

Please read the machine manufacturer's instructions.

Notes

Simulation

5.1	General	5-256
5.2	Start/abort program	5-256
5.3	Representation as a plan view	5-258
5.4	Representation as a 3-plane view	5-259
5.5	Zoom a finished part viewport	5-260
5.6	Three-dimensional representation of finished part.....	5-261
5.6.1	Change position of finished part.....	5-261
5.6.2	Cut open finished part	5-262
5.6.3	Update finished part display	5-262

5.1 General



Function

To simulate the machining process, the control system completely calculates the currently selected program and displays the result in graphic form.

You can select the following modes of representation for simulation:

- Plan view
- 3-plane view
- Volume model

The simulation function displays tools and workpiece contours in their correct proportions. Cylindrical die-sinking cutters, bevel cutters, bevel cutters with corner rounding and tapered die-sinking cutters are displayed as end milling tools.

Transformation of the coordinate system by means of the work offset, coordinate transformation, cylinder peripheral surface transformation and swiveling functions are not automatically displayed. In order view the machining operations after a transformation, you can define a new blank in the program (see Section "Change program settings").

5.2 Start/abort program



Precondition



Function

Start program

You have selected the program you want to simulate, i.e.

- a ShopMill program or a
- G code program

and called it in the Program Editor.

Press soft key "Simulation".

In the case of ShopMill programs, the dimensions of the blank for simulation are taken from the program header.

If a subroutine is called in the program, ShopMill evaluates the program header of the subroutine and uses the blank defined there for graphically displaying the part. The settings from the subroutine header remain effective, even after the subroutine has been executed. If you want to retain the blank used in the main program, delete the data relating to the blank in the subroutine header.

With G code programs, you must specify the dimensions of the blank or the selected viewport yourself.

Settings

With a G code program, select soft key "Settings" and enter the dimensions of your choice (see also Section "Create a new program; define a blank").

These dimensions are stored for simulation of the next G code program. If you set the "Blank" parameter to "off", the dimensions will be deleted.

Starts the program.

Processing time

The processing time (in hours/minutes/seconds) indicates the approximate time that would actually be required to execute the machining program on the machine (incl. tool change).

The timer is stopped if the program is interrupted.

Abort program

Press the "End" soft key if you want to cancel the simulation.

End

The program is restarted when you press soft key "Simulation".

Simu-
lation

5.3 Representation as a plan view



Select with soft key

Function

You can display the contour as a plan view by pressing this soft key. A depth display indicates the current depth at which machining is currently taking place.

The following applies with respect to depth display in this graphic: "The deeper, the darker".

Top view

Example of a plan view display of a finished part:

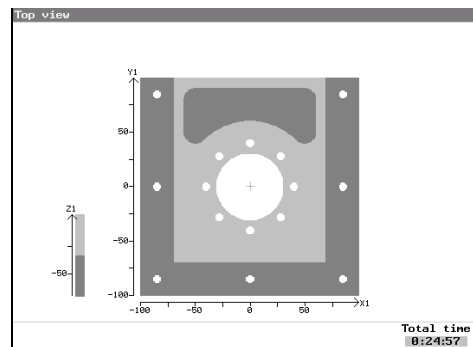

5.4 Representation as a 3-plane view



Select with soft key

Function

The process is represented as a plan view with 2 sections, similar to a technical drawing.

Functions for zooming viewports are provided in the 3-plane view.





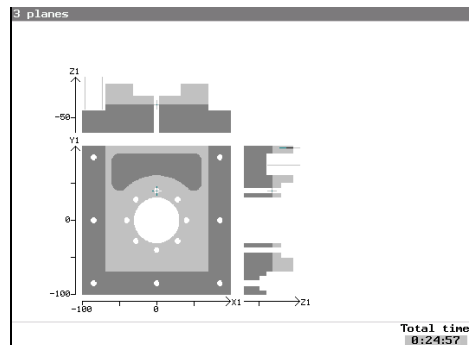



Example of a 3-plane view of a finished part:



Shift cutting planes

The cross-hair can be positioned in the plan view to display the cutting plane in the respective side view. Example of a volume model (finished part):

To reveal concealed contours, you can shift the cutting planes to any position you want in the 3-plane display. This way you can make hidden contours visible.

Shift in the ...	with keys ...
y plane	 
x plane	 
z plane	 

5.5 Zoom a finished part viewport



Function

Functions for displaying a more detailed representation of a finished part are available

- in the plane view and
- in the 3-plane display.

Select with soft key

Details

Zoom a viewport

Soft keys/keys	Meaning
To origin	You return to the initial display
Zoom + Zoom -	You can use soft key "Zoom +" or "Zoom -" to display the current screen contents in a higher or lower resolution. Use the cursor or "Paging" keys to position the cross-hair in the center of the selected viewport.
- +	Note: The same functions are provided by the "+" and "-" keys on the operator panel.
Auto Zoom	Press this soft key to display a window-proportionate representation of all travel paths in the graphic display area.

5.6 Three-dimensional representation of finished part



Select with soft key

Function

The finished part is displayed as a volume model. The simulation window displays the current machining status.

You can display concealed contours and views on the volume model by

- changing the position about the vertical axis or
- cutting open the volume model at the desired point.

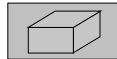

Example of a volume model (finished part):

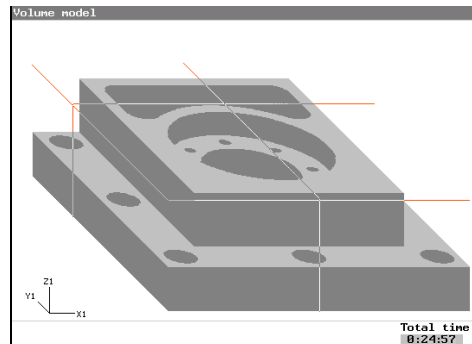





5.6.1 Change position of finished part

Select with soft key

Details

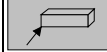
Select views

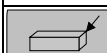
You can select one of the following views:

	Left-hand side of part from front
	Right-hand side of part from front
	Right-hand side of part from rear
	Left-hand side of part from rear

5.6.2 Cut open finished part

Precondition

You have selected one side of the finished part.

Select with soft key

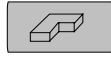

Shift cutting planes

To make concealed contours visible, shift the cutting planes using the cursor and "Paging" keys (see also Section "Representation in 3-plane view") to any position.

Update

The new setting is updated when you select this soft key.

Example of a cut volume model (finished part):

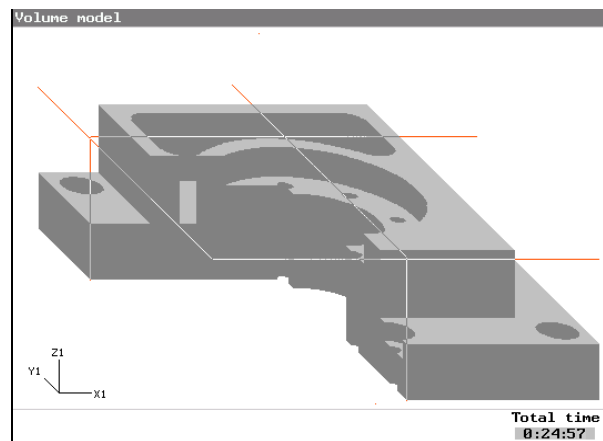

5.6.3 Update finished part display

Precondition

You are in "Volume model" representation mode and have started the program.

Update

While you are testing the program, the 3D representation of the finished part is refreshed to correspond to the latest machining status every time you press soft key "Update".

File Management

6.1	Manage programs with ShopMill	6-264
6.2	Manage programs with PCU 20	6-265
6.2.1	Open program	6-267
6.2.2	Execute a program	6-268
6.2.3	Multiple clamping	6-268
6.2.4	Execute G code program from floppy disk drive or network drive	6-271
6.2.5	Create new directory/program	6-272
6.2.6	Select several programs	6-273
6.2.7	Copying/renaming directories/programs	6-274
6.2.8	Deleting directories/programs	6-275
6.2.9	Execute program via RS-232 interface	6-276
6.2.10	Read program in/out via RS-232 interface	6-277
6.2.11	Display error log	6-279
6.2.12	Save/read in tool data/zero point data	6-279
6.3	Manage programs with PCU 50	6-282
6.3.1	Open program	6-284
6.3.2	Execute a program	6-285
6.3.3	Multiple clamping	6-286
6.3.4	Loading/unloading program	6-288
6.3.5	Execute G code program from hard disk, floppy disk drive or network drive	6-289
6.3.6	Create new directory/program	6-291
6.3.7	Select several programs	6-292
6.3.8	Copying/renaming/moving directories/programs	6-293
6.3.9	Deleting directories/programs	6-295
6.3.10	Execute program via RS-232 interface	6-296
6.3.11	Display error log	6-298
6.3.12	Save/read in tool data/zero point data	6-298

6.1 Manage programs with ShopMill



All programs that you have created in ShopMill for machining workpieces are stored in the main NC memory.

You can access these programs at any time via the Program Manager to execute them, edit, copy or rename them. You can delete programs you no longer need to free disk space.

ShopMill offers several options for exchanging programs and data with other workstations:

- Own hard disk (PCU 50 only)
- RS-232 interface
- Floppy disk drive
- Network connection

The following sections describe program management with PCU 20 or PCU 50 as an alternative.

Find out which PCU your ShopMill software is running on and then either read Section

6.2 Manage programs with PCU 20

or Section

6.3 Manage programs with PCU 50.

6.2 Manage programs with PCU 20



With the ShopMill variant with PCU 20, all programs and data are stored in the NC main memory.

You can read programs and data in/out via the RS-232 interface.

You can also display the directory structure on diskettes or network drives.

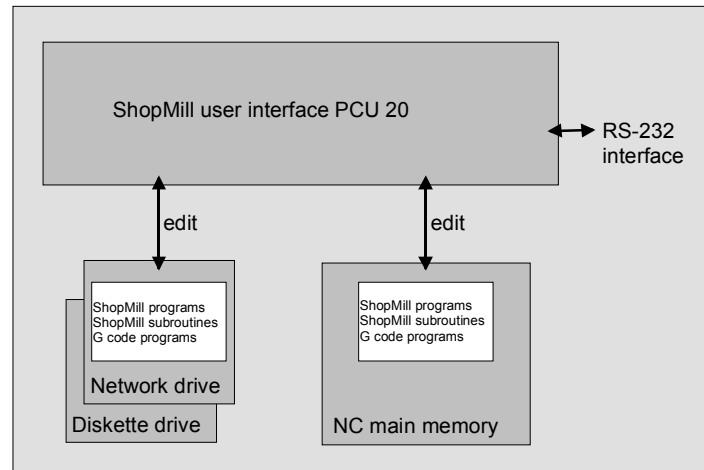

Data management with PCU 20

The Program Manager provides an overview of all directories and programs.

DIRECTORY			
Name	Type	Size	Date/time
SHOPMILL	WPD	NCK-Dir.	27.09.2002 10:52
TEMP	WPD	NCK-Dir.	27.09.2002 10:52

New

Rename

Mark

Copy

Paste

Delete

Continue

Free memory NC: 457240

NC F:/nc files a:

Program Manager PCU20

In the horizontal soft key bar you can select the memory medium for which you want to display directories and programs. In addition to the "NC" soft key, via which the data in the NC working memory can be

displayed, soft keys 2 to 5 can also be assigned. You can use them to display the directories and programs on the floppy disk and network drives:

Please read the machine manufacturer's instructions.

In the overview, the symbols have the following meaning:



Directory



Program



Zero point data/tool data

The directories and programs are always listed together with the following information:

- Name
The name can consist of max. 24 characters. When the data is transferred to external systems, the name is truncated after 8 characters.
- Type
Directory: WPD
Program: MPF
Zero point data/tool data: INI
- Size (in bytes)
- Date/time (of creation or last change)

ShopMill stores the programs that are created internally for calculating the stock removal processes in the "TEMP" directory.

Information about memory allocation in the NC is displayed above the horizontal soft key bar.



Open a directory

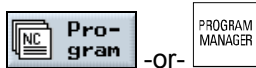

- Press the "Program" key or the "Program Manager" key.

The directory overview is displayed.



- Use the soft keys to select the memory medium.

- Position the cursor on the directory you want to open.

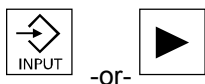

- Press the "Input" or "Cursor right" key.

All programs in this directory are now displayed.

Return to the higher level directory



- Press the "Cursor left" key with the cursor on any line.

-or-



- Position the cursor on the return jump line.

-and-



-or-



- Press the "Input" or "Cursor left" key.

The higher directory level is displayed.

6.2.1 Open program



If you want to look at a program in greater detail, or make changes to it, display the program in the machining plan.



- Press the "Program" soft key.

The directory overview is displayed.

- Position the cursor on the program you want to open.

- Press the "Input" or "Cursor right" key.



-or-



The selected program is opened in the "Program" operating area. The machining plan is displayed.

6.2.2 Execute a program



You can select all programs that are saved on your system at any time to use them for machining workpieces automatically.



➤ Open the Program Manager.

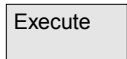

- Position the cursor on the program you want to execute.
- Press soft key "Execute".

ShopMill switches to "Machine Auto" operating mode and uploads the program.



➤ Then press the "Cycle Start" key.

Workpiece machining is initiated (see also Section "Automatic mode".)



If the program is already open in the "Program" operating area, press the "Execute" soft key to load the program in "Machine Auto" mode. You can start machining the workpiece there by pressing the "Cycle Start" key.

6.2.3 Multiple clamping



The "Multiple clamping" function provides optimized tool change over several workpiece clampings. Firstly this shortens the idle times. Secondly, time is no longer lost for tool changes as - in so far as possible - all machining of a workpiece in all clampings is performed first before the next tool change is triggered.



You can use rotating clamping bridges in addition to flat clamping bridges if supported by the machine manufacturer.

Please read the machine manufacturer's instructions.

You can either execute the same program several times on the different clampings or select different programs.



The "Multiple clamping for different programs" function is a software option.

The multiple clamping function creates one single program from several different programs. The tool sequence within a program remains unchanged. Cycles and subroutines are not opened, position patterns are processed as closed units.

The individual programs must meet the following requirements:

- ShopMill programs only
- Program must have been tested
- Program for the 1st clamping must have been trial run
- No markers/repetitions, i.e. no branches in the program
- No inch/metric switchover
- No work offsets
- No coordinate transformation (translation, scaling, etc.)
- Contours must have unique names, i.e. the same contour name must not be called in several different programs
- The "Starting point" parameter must not be set to "manual" in the stock removal cycle (contour milling).
- No modal settings, i.e. settings that are effective for all subsequent program blocks (only with multiple clamping for different programs)
- Max. of 50 contours per clamping
- Max. of 49 clampings

You can substitute subroutines for the markers or repetitions which may not be included in programs for multiple clampings.

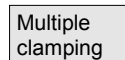
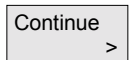

- Open the Program Manager.
- Press the "Continue" and "Multiple clamping" soft keys.
- Specify the number of clampings and the number of the first work offset to be used.
The clampings are processed in ascending sequence from the start work offset. The work offsets are defined in the "Tools/Work Offsets" menu (see Section "Work offsets").
- Enter a name for the new, global program (XYZ.MPF).
- Press soft key "OK".

A list is displayed in which the different programs must be assigned to the work offsets. Not all work offsets, i.e. clampings, must be assigned to programs, but at least two.

Program
selection

OK

On all
clampings

Delete
selection

Delete all

Calculate
program

- Press the "Program selection" soft key.

The program overview is displayed.

- Position the cursor on the program you want to execute.
- Press soft key "OK".

The program is included in the assignment list.

- Repeat this process until a program is assigned to every required work offset.

- If you wish to execute the same program on all clampings, select soft key "On all clampings".

You can assign different programs to individual work offsets first, and then assign one program to the remaining work offsets by selecting soft key "On all clampings".

- Press the "Delete selection" or "Delete all" soft key if you want to clear individual or all programs from the assignment list.

- Press the "Calculate program" soft key when the assignment list is complete.

This optimizes the tool changes.

The global program is then renumbered. The number of the current clamping is specified every time the program switches from one clamping to another.

Apart from the global program (XYZ.MPF), the file XYZ_MCD.INI is also set up in which the assignment between work offsets and programs is stored. Both programs are stored in the directory that was previously selected in the Program Manager.

If you switch from the assignment list (without "Abort" or "Create program") to another function and then call the "Multiple clamping" function later on, the same assignment list is displayed again.



6.2.4 Execute G code program from floppy disk drive or network drive

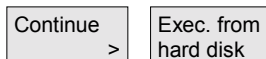
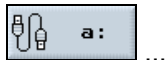

If your NC memory resources are low, you can execute G code programs from floppy disk drive/network drive.

Then instead of loading the entire G code program into the NC memory before execution, only the first part is loaded. While the first part is being executed, subsequent program blocks are continuously loaded.

With execution from floppy disk drive/network drive, the G code program remains stored on this drive.

You cannot execute ShopMill programs from floppy disk/network drive.

➤ Open the Program Manager.

➤ Use the soft keys to select the floppy disk drive/network drive.

➤ Position the cursor on the directory in which you want to execute a G code program.

➤ Press the "Input" or "Cursor right" key.

The directory is opened.

➤ Position the cursor on the G code program that you want to execute.

➤ Press the "Continue" and "Execution from hard disk" soft keys.

ShopMill switches to "Machine Auto" mode and uploads the G code program.

➤ Press the "Start" key.

Workpiece machining is initiated (see also Section "Automatic mode").

The program contents are loaded continuously to the NC main memory while the program is being processed.

6.2.5 Create new directory/program



Directory structures facilitate administration of your programs and data. You can create as many subdirectories as you want in one directory.

You can also create programs in a subdirectory/directory and then create program blocks for the program (see Section "Programming with ShopMill").

The new program is automatically stored for you in the NC main memory.



Create a directory

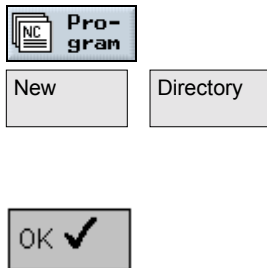

- Open the Program Manager.
- Press the "New" and "Directory" soft keys.
- Enter a new directory name.
- Press soft key "OK".

The new directory is created.

Create programs

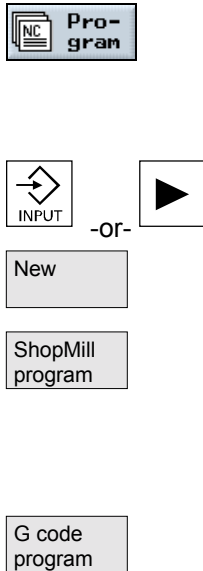

- Open the Program Manager.
- Position the cursor on the directory in which you want to create a new program.
- Press the "Input" or "Cursor right" key.
- Press the "New" soft key.
- Now press the "ShopMill program" soft key if you want to create a ShopMill program.
(See Section "Programming with ShopMill")
- or-
- Press the "G code program" soft key if you want to create a G code program.
(See Section "Programming with G code")

6.2.6 Select several programs



In order to copy or delete several programs at once, you can select multiple programs at once, block by block or individually.



Selecting several programs block by block



-or-



- Open the Program Manager.
- Position the cursor on the first program you want to select.
- Press the "Mark" soft key.
- Broaden your program selection by pressing the cursor up or down keys.

The entire program block is highlighted.

Selecting several separate programs



-or-



- Open the Program Manager.
- Position the cursor on the first program you want to select.
- Press the "Select" soft key.
- Then move the cursor to the next program you want to select.
- Press the "Select" soft key again.

The separately selected programs are highlighted.

6.2.7 Copying/renaming directories/programs



If you want to create a new directory or program that is to be similar to an already existing one, you can save time by copying the old directory or program and then modifying selected programs or program blocks only.

You can also use the copy and insert capabilities for directories and programs to exchange data with other ShopMill systems via diskette or the network drive.

You can also rename directories or programs.



You cannot rename a program if it is loaded in the "Machine Auto" operating mode at the same time.



Copying directory/program



Copy

Insert

OK ✓

OK ✓

- Open the Program Manager.
- Position the cursor on the directory/program you want to copy.
- Press the "Copy" soft key.
- Select the directory level where you want to insert the copy of your directory/program.
- Press the "Insert" soft key.

The copied directory/program is inserted in the selected directory level. If there already is a directory/program with the same name in this level, you are prompted whether you want to overwrite the directory/program or insert it under another name.

- Press the "OK" soft key if you want to overwrite the directory/program.

-or-

- Specify another name if you want to save the directory/program under another name.

-and-

- Press soft key "OK".

Renaming directories/programs

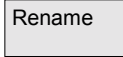

- Open the Program Manager.
- Position the cursor on the directory/program you want to rename.
- Press the "Rename" soft key.
- In the "To:" field, enter the new directory name or program name. The name must be unique, i.e. you cannot have two directories or programs with the same name.
- Press soft key "OK".

The directory/program is renamed.

6.2.8 Deleting directories/programs

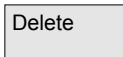
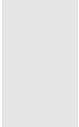

It is advisable to regularly delete programs or directories that you are no longer using so that your data management remains clearly structured and the NC main memory is released again. Save this data on an external data storage medium if required (see Section "Read program in/out via RS-232 interface").

Remember when you delete a directory, all programs, tool data, zero point data and subdirectories contained in this directory are deleted too.

If you want to release space in the NC memory, delete the contents of the "TEMP" directory. ShopMill stores the programs that are created internally for calculating the stock removal processes in this directory.

- Open the Program Manager.
- Position the cursor on the directory/program you want to delete.
- Press the "Delete" soft key.

The selected directory or program is deleted.

6.2.9 Execute program via RS-232 interface



Programs saved on external data storage systems can be executed directly via the RS-232 interface. This means you do not need to read these programs in first before using them to machine a workpiece. If a program needs more memory space for execution than is available in the NC main memory, the program contents are continuously loaded via the RS-232 interface.



The RS-232 interface on the controller and on the external data storage system must be adapted to one another, i.e. you must make the same settings for each RS-232 interface.

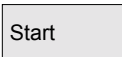
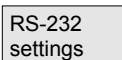
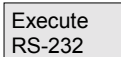
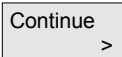

- Open the Program Manager.
- Press the "Continue" and "Execute RS-232" soft keys.
- Press the "RS-232 settings" soft key if you want to set up the interface.
- Make your required settings.
- Press the "Back" soft key.

The interface settings are saved.

- On the other side, select the program that you want to execute.
- Start the transfer on the other system.
- Press soft key "Start".

ShopMill switches to "Machine Auto" mode and uploads part of the program.

- Then press the "Cycle Start" key.

Workpiece machining is initiated (see also Section "Automatic mode"). The program contents are loaded continuously to the NC main memory while the program is being processed. After execution via the RS-232 interface, the program remains stored on the external data storage system.

6.2.10 Read program in/out via RS-232 interface



Programs can be exchanged with other ShopMill stations using an external data storages system over the RS-232 interface.

In addition, you can use this procedure to swap out data you are not currently using to free more NC main memory. When you want to use these swapped out programs again, you can swap them in any time.



When you read a program out from/in to ShopMill, all ShopMill subroutines are transferred too.

You can also read in/out several programs in one operation.

The RS-232 interface on the controller and on the external data storage system must be adapted to one another, i.e. you must make the same settings for each RS-232 interface.



Make sure that you set the correct file format (binary/PC, punched tape or punched tape/ISO format) when you read out a program. Otherwise, the other station will not be able to interpret the program.



Read out program

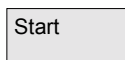
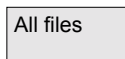
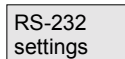
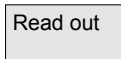
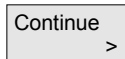

- Open the Program Manager.
- Position the cursor on the program you want to read out.
- Select soft keys "Continue" and "Read out".
- Press the "RS-232 settings" soft key if you want to set up the interface.
- Make your required settings.
- Press the "Back" soft key.

The interface settings are saved.

- Press the "All files" soft key if you want to select all displayed programs.
- Start the transfer on the other system.
- Press soft key "Start".

The selected program and all its ShopMill subroutines are read out. The "Read out" window displays the name of the program being read out and the number of transferred bytes.



- Press the "Stop" soft key if you want to cancel the data transfer.
- Then press the "Start" soft key again to resume the data transfer operation.

Read in program

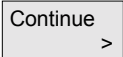

- Open the Program Manager.
- Select soft keys "Continue" and "Read in".
- Press the "RS-232 settings" soft key if you want to set up the interface.
- Make your required settings.
- Press the "Back" soft key.



The interface settings are saved.

- On the other system, select the programs you want to read in.
- Start the transfer on the other system.
- Press soft key "Start".



The "Read in" window displays the name of the program being read in and the number of transferred bytes. The program is stored in the directory stated in the program header.



- Press the "Stop" soft key if you want to cancel the data transfer.
- Then press the "Start" soft key again to resume the data transfer operation.

6.2.11 Display error log

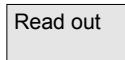
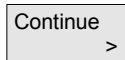

-OR-

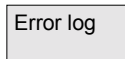
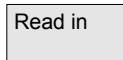

If errors occur during data transfer via the RS-232 interface, ShopMill records them in an error log.

- Open the Program Manager.
- Press the "Continue" soft key.
- Press the "Read out" or "Read in" soft key.
- Then press the "Error log" soft key.

The data transfer log is displayed.

6.2.12 Save/read in tool data/zero point data



You can also store tool data and zero point settings in addition to programs.

You can use this function, for example, to save the tool and zero point data for a specific ShopMill program. If you want to execute this program again later, you can access these settings quickly.

In this way, you can easily enter tool data that you have determined using an external tool presetting device into the tool management system. See:

References: /FBSP/, Description of Functions ShopMill



You can choose which data you want to save:

- Tool data
- Magazine assignments
- Zero points
- Basic zero point

In addition you can determine the scope of the data backup:

- Full tool list/all zero points
- All tool data/zero points used in the program

You can only read out the magazine assignments if your system provides support for loading and unloading tool data to and from the tool-holding magazine (see Section "Loading/unloading tools").





Backing up data

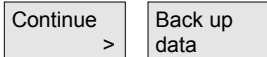

- Open the Program Manager.
- Position the cursor on the program for which you want to back up the tool and zero point data.
- Press the "Continue" and "Back up data" soft keys.
- Select the data you want to back up.
- Change the suggested name if required.
The name suggested as the name for your tool and zero point file is the name of the originally selected program with the extension "..._TMZ".
- Press soft key "OK".

The tool/zero point data are saved in the same directory as the selected program.

If your directory already contains a tool and zero point file with the same file name, then they are overwritten with the new data.

Read in data

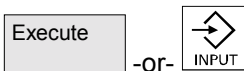

- Open the Program Manager.
- Position the cursor on the backed up tool/zero point data which you want to read back in again.
- Press the "Execute" soft key or the "Input" key.

The "Read in backup data" window appears.

- Select which data (tool offset data, magazine assignments, zero point data, basic work offset) you wish to read in.
- Press soft key "OK".

The data are read in.

Depending on which data you have selected, ShopMill will behave as follows:

All tool offset data

First all tool management data is deleted, then the backup data is read in.

All tool offset data used in the program

If at least one of the tools to be read in already exists in the tool management, you can choose from the following options.

- Press the "Replace all" soft key if you want to read in all tool data. Any existing tools are overwritten without warning.

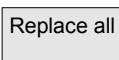

-or-

A rectangular button with a light gray background and a thin black border. The text "Replace none" is centered in a black sans-serif font.

- Press the "Replace none" soft key if you want to cancel the data read in process.

-or-

A rectangular button with a light gray background and a thin black border. The text "No" is in black, and a red "X" icon is to its right.

- Press the "No" soft key if you want to retain the existing tool.

-or-

A rectangular button with a light gray background and a thin black border. The text "Yes" is in black, and a green checkmark icon is to its right.

- Press the "Yes" soft key if you want to overwrite the existing tool.

With the tool management option without loading/unloading, the old tool is deleted; in the case of the "with loading/unloading" variant, the old tool is unloaded beforehand.

If you change the tool name before pressing "Yes" to read in the data, the tool is entered in the tool list as well.

Work offsets

Existing work offsets are always overwritten when data are read in.

Magazine assignments

If the magazine assignments are not read in with the other data, the tools are entered without location number in the tool list.

6.3 Manage programs with PCU 50



The ShopMill variant with PCU 50 has its own hard disk in addition to the NC main memory. Therefore, any program that is not currently needed in the NC can be stored on the hard disk.

In addition, you can display the directory structures of floppy disk drives and network drives as well as read programs and data in/out via an RS-232 interface.

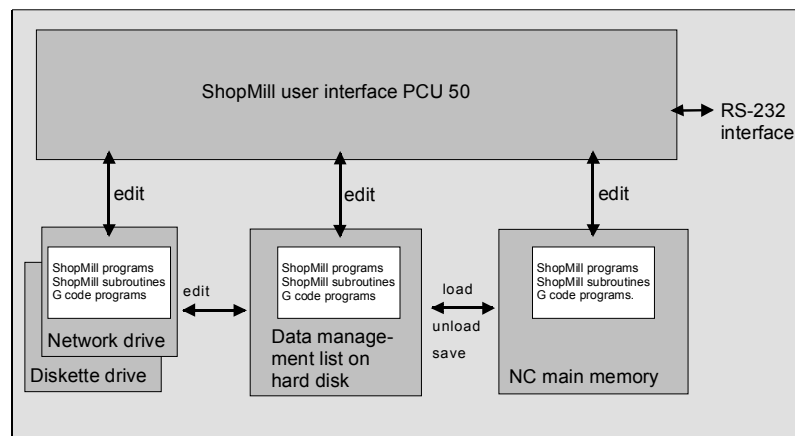

Data management with PCU 50

The Program Manager provides an overview of all directories and programs.

DIRECTORY				
Name	Type	Loaded	Size	Date/time
SHOPMILL	WPD	X	NCK-Dir.	27.09.2002 10:52
TEMP	WPD	X	NCK-Dir.	27.09.2002 10:52

Free memory
Hard disk : 1.2 GBytes
NC: 457240

NC
F:/nc_files
a:

Program Manager PCU 50

In the horizontal soft key bar you can select the memory medium for which you want to display directories and programs. In addition to the "NC" soft key, via which the data in the NC main memory and the data management directory on the hard disk can be displayed, soft keys 2

to 5 can also be assigned. You can use them to display the directories and programs on the following data storage media:

- Network drives (network card required)
- Floppy disk drive
- Archive directory on the hard disk

Please read the machine manufacturer's instructions.

In the overview, the symbols have the following meaning:

Directory



Program



Zero point data/tool data



The directories and programs are always listed together with the following information:

- Name
The name can consist of max. 24 characters. When the data is transferred to external systems, the name is truncated after 8 characters.
- Type
Directory: WPD
Program: MPF
Zero point data/tool data: INI
- Loaded
You can tell by a cross in the "Loaded" column whether the program is still contained in the NC main memory (X) or is swapped out to your hard disk ().
- Size (in bytes)
- Date/time (of creation or last change)

ShopMill stores the programs that are created internally for calculating the stock removal processes in the "TEMP" directory.

Information about memory allocation on the hard disk and in the NC is displayed above the horizontal soft key bar.



Open a directory

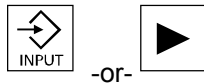
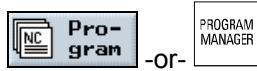

- Press the "Program Manager" key or "Program" soft key.

The directory overview is displayed.

- Use the soft keys to select the memory medium.
- Position the cursor on the directory you want to open.
- Press the "Input" or "Cursor right" key.

All programs in this directory are now displayed.

Return to the higher level directory

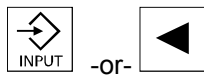

- Press the "Cursor left" key with the cursor on any line.

-or-

- Position the cursor on the return jump line.

-and-

- Press the "Input" or "Cursor left" key.

The higher directory level is displayed.

6.3.1 Open program



If you want to look at a program in greater detail, or make changes to it, display the program in the machining plan.

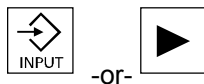

- Press the "Program" soft key.

The directory overview is displayed.

- Position the cursor on the program you want to open.
- Press the "Input" or "Cursor right" key.

The selected program is opened in the "Program" operating area. The machining plan is displayed.

6.3.2 Execute a program

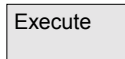

You can select all programs that are saved on your system at any time to use them for machining workpieces automatically.

- Open the Program Manager.
- Position the cursor on the program you want to execute.
- Press soft key "Execute".

ShopMill switches to "Machine Auto" operating mode and uploads the program.

- Then press the "Cycle Start" key.

Workpiece machining is initiated (see also Section "Automatic mode").

If the program is already open in the "Program" operating area, press the "Execute" soft key to load the program in "Machine Auto" mode. You can start machining the workpiece there by pressing the "Cycle Start" key.

6.3.3 Multiple clamping



The "Multiple clamping" function provides optimized tool change over several workpiece clampings. Firstly this shortens the idle times. Secondly, time is no longer lost for tool changes as - in so far as possible - all machining of a workpiece in all clampings is performed first before the next tool change is triggered.



You can use rotating clamping bridges in addition to flat clamping bridges if supported by the machine manufacturer.

Please read the machine manufacturer's instructions.

You can either execute the same program several times on the different clampings or select different programs.



The "Multiple clamping for different programs" function is a software option.

The multiple clamping function creates one single program from several different programs. The tool sequence within a program remains unchanged. Cycles and subroutines are not opened, position patterns are processed as closed units.

The individual programs must meet the following requirements:

- ShopMill programs only
- Program must have been tested
- Program for the 1st clamping must have been trial run
- No markers/repetitions, i.e. no branches in the program
- No inch/metric switchover
- No work offsets
- No coordinate transformation (translation, scaling, etc.)
- Contours must have unique names, i.e. the same contour name must not be called in several different programs
- The "Starting point" parameter must not be set to "manual" in the stock removal cycle (contour milling).
- No modal settings, i.e. settings that are effective for all subsequent program blocks (only with multiple clamping for different programs)
- Max. of 50 contours per clamping
- Max. of 99 clampings



You can substitute subroutines for the markers or repetitions which may not be included in programs for multiple clampings.



Continue >

Multiple clamping

OK

Program selection

OK

On all clampings

Delete selection

Delete all

Calculate program

- Open the Program Manager.
- Press the "Continue" and "Multiple clamping" soft keys.
- Specify the number of clampings and the number of the first work offset to be used.
The clampings are processed in ascending sequence from the start work offset. The work offsets are defined in the "Tools/Work Offsets" menu (see Section "Work offsets").
- Enter a name for the new, global program (XYZ.MPF).
- Press soft key "OK".

A list is displayed in which the different programs must be assigned to the work offsets. Not all work offsets, i.e. clampings, must be assigned to programs, but at least two.

- Press the "Program selection" soft key.

The program overview is displayed.

- Position the cursor on the program you want to execute.
- Press soft key "OK".

The program is included in the assignment list.

- Repeat this process until a program is assigned to every required work offset.
- If you wish to execute the same program on all clampings, select soft key "On all clampings".
You can assign different programs to individual work offsets first, and then assign one program to the remaining work offsets by selecting soft key "On all clampings".

- Press the "Delete selection" or "Delete all" soft key if you want to clear individual or all programs from the assignment list.
- Press the "Calculate program" soft key when the assignment list is complete.

This optimizes the tool changes.

The global program is then renumbered. The number of the current clamping is specified every time the program switches from one clamping to another.

Apart from the global program (XYZ.MPF), the file XYZ_MCD.INI is also set up in which the assignment between work offsets and programs is stored. Both programs are stored in the directory that was previously selected in the Program Manager.



If you switch from the assignment list (without "Abort" or "Create program") to another function and then call the "Multiple clamping" function later on, the same assignment list is displayed again.

6.3.4 Loading/unloading program



If you do not want to execute one or more programs in the foreseeable future, you can unload them from the NC memory. The programs then reside on the hard disk and the NC memory is released again.



As soon as you execute a program that was swapped out, it is automatically swapped in to the NC memory.

You can, however, also load one or more ShopMill programs in the NC main memory without executing them immediately.



Programs that are in "Machine Auto" mode cannot be swapped out from the NC memory to the hard disk.



Unloading programs

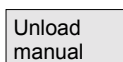
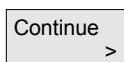

- Open the Program Manager.
- Position the cursor on the program you want to unload from the NC main memory.
- Press the "Continue" and "Unload manual" soft keys.

The selected program is no longer marked by an "X" in the "Loaded" column.

The line indicating the available memory space shows that the NC memory was freed again.

Loading programs

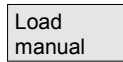
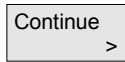

- Open the Program Manager.
- Position the cursor on the program you want to load into the NC main memory.
- Press the "Continue" and "Load manual" soft keys.

The selected program is now marked by an "X" in the "Loaded" column.

6.3.5 Execute G code program from hard disk, floppy disk drive or network drive



If your NC memory resources are low, you can also execute G code programs from hard disk, floppy disk or network drive.

Then instead of loading the entire G code program into the NC memory before execution, only the first part is loaded. While the first part is being executed, subsequent program blocks are continuously loaded.

With execution from hard disk, floppy disk drive or network drive, the G code program remains stored on this drive.

You cannot execute ShopMill programs from hard disk or floppy disk/network drive.



Execute G code program from hard disk



-or-

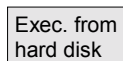
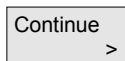

- Open the Program Manager.
- Position the cursor on the directory in which you want to execute a G code program from the hard disk.
- Press the "Input" or "Cursor right" key.

The program overview is displayed.

- Position the cursor on the G code program you want to execute from the hard disk (without "X").

- Press the "Continue" and "Execution from hard disk" soft keys.

ShopMill switches to "Machine Auto" mode and uploads the G code program.

- Press the "Start" key.

Workpiece machining is initiated (see also Section "Automatic mode"). The program contents are loaded continuously to the NC main memory while the program is being processed.

Execute G code program from floppy disk/network drive



-or-

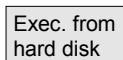
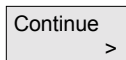

- Open the Program Manager.
- Use the soft keys to select the floppy disk drive/network drive.
- Position the cursor on the directory in which you want to execute a G code program.
- Press the "Input" or "Cursor right" key.

The directory is opened.

- Position the cursor on the G code program that you want to execute.
- Press the "Continue" and "Execution from hard disk" soft keys.

ShopMill switches to "Machine Auto" mode and uploads the G code program.

- Press the "Start" key.

Workpiece machining is initiated (see also Section "Automatic mode").
The program contents are loaded continuously to the NC main memory while the program is being processed.

6.3.6 Create new directory/program



Directory structures facilitate administration of your programs and data. You can create as many subdirectories as you want in one directory.

You can also create programs in a subdirectory/directory and then create program blocks for the program (see Section "Programming with ShopMill").

The new program is automatically stored for you in the NC main memory.



Create a directory



New

Directory

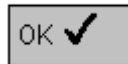

- Open the Program Manager.
- Press the "New" and "Directory" soft keys.
- Enter a new directory name.
- Press soft key "OK".

The new directory is created.

Create programs



-or-



New

ShopMill
program

G code
program

- Open the Program Manager.
- Position the cursor on the directory in which you want to create a new program.
- Press the "Input" or "Cursor right" key.
- Press the "New" soft key.
- Now press the "ShopMill program" soft key if you want to create a ShopMill program.
(See Section "Programming with ShopMill")

-or-

- Press the "G code program" soft key if you want to create a G code program.
(See Section "Programming with G code")

6.3.7 Select several programs



In order to copy or delete several programs at once, you can select multiple programs at once, block by block or individually.



Selecting several programs block by block

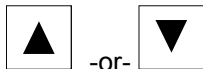

- Open the Program Manager.
- Position the cursor on the first program you want to select.
- Press the "Mark" soft key.
- Broaden your program selection by pressing the cursor up or down keys.

The entire program block is highlighted.

Selecting several separate programs

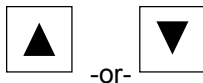

- Open the Program Manager.
- Position the cursor on the first program you want to select.
- Press the "Select" soft key.
- Then move the cursor to the next program you want to select.
- Press the "Select" soft key again.

The separately selected programs are highlighted.

6.3.8 Copying/renaming/moving directories/programs



If you want to create a new directory or program that is to be similar to an already existing one, you can save time by copying the old directory or program and then modifying selected programs or program blocks only.

You can also move directories or programs or rename them.

You can also use the copy, cut and insert capabilities for directories and programs to exchange data with other ShopMill systems via diskette or the network drive.



You cannot rename a program if it is loaded in the "Machine Auto" operating mode at the same time.



Copying directory/program

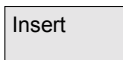
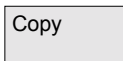

- Open the Program Manager.
- Position the cursor on the directory/program you want to copy.
- Press the "Copy" soft key.
- Select the directory level where you want to insert the copy of your directory/program.
- Press the "Insert" soft key.

The copied directory/program is inserted in the selected directory level. If there already is a directory/program with the same name in this level, you are prompted whether you want to overwrite the directory/program or insert it under another name.

- Press the "OK" soft key if you want to overwrite the directory/program.

-or-

- Specify another name if you want to save the directory/program under another name.

-and-

- Press soft key "OK".

Renaming directories/programs



Rename

OK ✓

- Open the Program Manager.
- Position the cursor on the directory/program you want to rename.
- Press the "Rename" soft key.
- In the "To:" field, enter the new directory name or program name. The name must be unique, i.e. you cannot have two directories or programs with the same name.
- Press soft key "OK".

The directory/program is renamed.

Moving directories/programs



Cut

Insert

OK ✓

- Open the Program Manager.
- Position the cursor on the directory/program you want to move.
- Press the "Cut" soft key.

The selected directory/program is cut out at this location and stored in the clipboard.

- Select the directory level where you want to insert the directory/program.
- Press the "Insert" soft key.

The directory/program is moved to the selected directory level. If there already is a directory/program with the same name in this directory level, you are prompted whether you want to overwrite the directory/program or insert it under another name.

- Press the "OK" soft key if you want to overwrite the directory/program.

-or-

- Specify another name if you want to save the directory/program under another name.

-and-

- Press soft key "OK".

OK ✓

6.3.9 Deleting directories/programs



It is advisable to regularly delete programs or directories that you are no longer using so that your data management remains clearly structured.

Save this data on an external data storage medium if required (see Section "Read program in/out via RS-232 interface").



Remember when you delete a directory, all programs, tool data, zero point data and subdirectories contained in this directory are deleted too.



If you want to release space in the NC memory, delete the contents of the "TEMP" directory. ShopMill stores the programs that are created internally for calculating the stock removal processes in this directory.

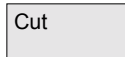

- Open the Program Manager.
- Position the cursor on the directory/program you want to delete.
- Press the "Cut" soft key.

The selected directory or program is deleted.

6.3.10 Execute program via RS-232 interface



Programs can be exchanged with other ShopMill stations using an external data storages system over the RS-232 interface.

In addition, you can use this procedure to swap out data you are not currently using to free the NC memory or hard disk. When you want to use these swapped out programs again, you can swap them in any time.



When you read a program out from/in to ShopMill, all ShopMill subroutines are transferred too.

You can also read in/out several programs in one operation.

The RS-232 interface on the controller and on the external data storage system must be adapted to one another, i.e. you must make the same settings for each RS-232 interface.



Make sure that you set the correct file format (binary/PC, punched tape or punched tape/ISO format) when you read out a program. Otherwise, the other station will not be able to interpret the program.



Read out program



Read out

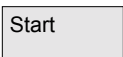
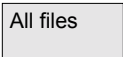
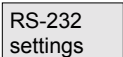

- Open the Program Manager.
- Position the cursor on the program you want to read out.
- Select soft keys "Continue" and "Read out".
- Press the "RS-232 settings" soft key if you want to set up the interface.
- Make your required settings.
- Press the "Back" soft key.

The interface settings are saved.

- Press the "All files" soft key if you want to read out all displayed programs.
- Start the transfer on the other system.
- Press soft key "Start".

The selected program and all its ShopMill subroutines are read out. The "Read out" window displays the name of the program being read out and the number of transferred bytes.

Stop

- Press the "Stop" soft key if you want to cancel the data transfer.
- Then press the "Start" soft key again to resume the data transfer operation.

Read in program

Program

Continue >

Read in

RS-232 settings

- Open the Program Manager.
- Select soft keys "Continue" and "Read in".
- Press the "RS-232 settings" soft key if you want to set up the interface.
- Make your required settings.
- Press the "Back" soft key.

back

The interface settings are saved.

- On the other system, select the programs you want to read in.
- Start the transfer on the other system.
- Press soft key "Start".

Start

The "Read in" window displays the name of the program being read in and the number of transferred bytes. The program is stored in the directory stated in the program header.

Stop

- Press the "Stop" soft key if you want to cancel the data transfer.
- Then press the "Start" soft key again to resume the data transfer operation.

6.3.11 Display error log



If errors occur during data transfer via the RS-232 interface, ShopMill records them in an error log.



Continue
>

Read out

Read in

-or-

Error log

- Open the Program Manager.
- Press the "Continue" soft key.
- Press the "Read out" or "Read in" soft key.
- Then press the "Error log" soft key.

The data transfer log is displayed.

6.3.12 Save/read in tool data/zero point data



You can also store tool data and zero point settings in addition to programs.

You can use this function, for example, to save the tool and zero point data for a specific ShopMill program. If you want to execute this program again later, you can access these settings quickly.

In this way, you can easily enter tool data that you have determined using an external tool presetting device into the toll management system. See:

References: /FBSP/, Description of Functions ShopMill



You can choose which data you want to save:

- Tool data
- Magazine assignments
- Zero points
- Basic zero point

In addition you can determine the scope of the data backup:

- Full tool list/all zero points
- All tool data/zero points used in the program

You can only read out the magazine assignments if your system provides support for loading and unloading tool data to and from the tool-holding magazine (see Section "Loading/unloading tools").





Backing up data

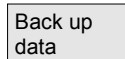
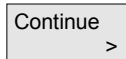

- Open the Program Manager.
- Position the cursor on the program for which you want to back up the tool and zero point data.
- Press the "Continue" and "Back up data" soft keys.
- Select the data you want to back up.
- Change the suggested name if required.
The name suggested as the name for your tool and zero point file is the name of the originally selected program with the extension "..._TMZ".
- Press soft key "OK".

The tool/zero point data are saved in the same directory as the selected program.

If your directory already contains a tool and zero point file with the same file name, then they are overwritten with the new data.

Read in data

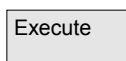

-or-



- Open the Program Manager.
- Position the cursor on the backed up tool/zero point data which you want to read back in again.
- Press the "Execute" soft key or the "Input" key.

The "Read in backup data" window appears.

- Select which data (tool offset data, magazine assignments, zero point data, basic work offset) you wish to read in.
- Press soft key "OK".

The data are read in.

Depending on which data you have selected, ShopMill will behave as follows:

All tool offset data

First all tool management data is deleted, then the backup data is read in.

All tool offset data used in the program

If at least one of the tools to be read in already exists in the tool management, you can choose from the following options.

- Press the "Replace all" soft key if you want to read in all tool data. Any existing tools are overwritten without warning.

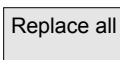

-or-

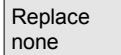
A rectangular button with a light gray background and a thin black border. The text "Replace none" is centered in a black sans-serif font.

- Press the "Replace none" soft key if you want to cancel the data read in process.

-or-

A rectangular button with a light gray background and a thin black border. The text "No" is in black, and a red "X" icon is to its right.

- Press the "No" soft key if you want to retain the existing tool.

-or-

A rectangular button with a light gray background and a thin black border. The text "Yes" is in black, and a green checkmark icon is to its right.

- Press the "Yes" soft key if you want to overwrite the existing tool.

With the tool management option without loading/unloading, the old tool is deleted; in the case of the "with loading/unloading" variant, the old tool is unloaded beforehand.

If you change the tool name before pressing "Yes" to read in the data, the tool is entered in the tool list as well.

Work offsets

Existing work offsets are always overwritten when data are read in.

Magazine assignments

If the magazine assignments are not read in with the other data, the tools are entered without location number in the tool list.



Alarms and Messages

7.1	Cycle alarms and messages	7-302
7.1.1	Error treatment in cycles	7-302
7.1.2	Cycle alarm overview	7-302
7.1.3	Messages in cycles	7-307
7.2	Alarms for ShopMill	7-308
7.2.1	Alarm overview	7-308
7.2.2	Select the alarm/message overview	7-309
7.2.3	Description of alarms	7-310
7.3	User data	7-318
7.4	Version display	7-320

7.1 Cycle alarms and messages

7.1.1 Error treatment in cycles

If the system detects an error status while processing a cycle, it generates an alarm and aborts cycle execution.

Alarms with numbers ranging from 61000 to 62999 are generated in cycles.

The reset criteria for these number ranges are

- NC-RESET for 61000 ... 61999 and
- CANCEL for 62000 ... 62999

The error text that is simultaneously displayed with the alarm number indicates the possible error cause.

7.1.2 Cycle alarm overview

The following table provides an overview of cycles that might be generated in machining cycles and tips for remedying the underlying errors.

Alarm number	Alarm text	Explanation, remedy
61000	"No tool offset active"	D offset must be programmed before cycle is called
61001	"Thread pitch incorrectly defined"	Check parameters for thread size and pitch settings (for contradiction)
61002	"Machining type incorrectly defined"	The machining type parameter has been set to the wrong value and needs to be altered.
61003	"No feedrate programmed in cycle"	The feedrate parameter has been set to the wrong value and needs to be altered.
61006	"Tool radius too large"	Select smaller tool
61007	"Tool radius too small"	Select larger tool
61009	"Active tool number = 0"	Load the required tool
61010	"Finishing allowance too large"	Reduce the finishing allowance setting
61011	"Invalid scaling"	The active scaling factor is not permissible for this cycle.
61012	"Different scales in one plane"	Cycle execution only possible with uniform scaling in the plane
61013	"Basic settings have been altered, program cannot be executed"	Check basic settings and alter them if necessary
61101	"Reference plane incorrectly defined"	If you choose to program relative depth settings, you must select different values for the reference and return planes. Alternatively, set an absolute depth value

61102	"No spindle direction programmed"	A spindle direction must be programmed
61103	"Number of holes is zero"	You have not programmed a value for the number of holes
61104	"Contour violation of slots"	Errors in parameterization of milling pattern in those parameters which define the position of slots on a circle and their shape
61105	"Cutter radius too large"	The diameter of the selected cutting tool is too large for the profile to be machined. You must either use a tool with a smaller radius or modify the contour
61106	"Number or spacing of circle elements"	Parameterization error, programmed circle elements cannot be arranged around a full circle
61107	"First drilling depth incorrectly defined"	First drilling depth is inverted in relation to total drilling depth
61108	"No valid settings for parameters _RAD1 and _DP1"	Parameters "Radius" and "Infeed depth per revolution" must be taken into account for insertion along helical path
61109	"Parameter _CDIR incorrectly defined"	Parameter defining milling direction is incorrectly defined
61110	"Finishing allowance on base > infeed depth"	Alter setting for depth infeed if necessary
61111	"Infeed width > tool diameter"	The programmed infeed width is greater than the diameter of the active tool. The infeed width must be reduced.
61112	"Tool radius negative"	The radius of the active tool is negative. This is illegal.
61113	"Parameter _CRAD for corner radius too large"	Reduce the parameter for corner radius
61114	"Direction of machining G41/G42 incorrectly defined"	Check the machining direction of tool radius compensation left/right and alter
61115	"Approach or retract mode (line/circle/plane/space) incorrectly defined"	The contour approach and retract mode has been incorrectly defined. Check parameters "Approach/retract mode" and "Approach/retract strategy".
61116	"Approach or retract path = 0"	The approach or retract path is set to zero, it must be increased.
61117	"Active tool radius <= 0"	The radius of the active tool is negative or set to zero. This is illegal.
61118	"Length or width = 0"	The length or width of the milling surface is not legal.
61119	"Nominal or core diameter incorrectly programmed"	Check thread geometry
61120	"Thread type internal, external not defined"	You must enter the internal, external thread type

7.1 Cycle alarms and messages

61121	"Number of teeth/cutting edge missing"	Enter the number of teeth/cutting edge for the active tool in the tool list
61122	"Safety clearance in the plane incorrectly defined"	The safety clearance is negative or zero. This is illegal.
61124	"Infeed width is not programmed"	In active simulation without a tool, a value for the infeed width must always be programmed.
61125	"Technology selection not defined correctly in parameter _TECHNO"	Check the settings in machine data 9855 and 9856.
61126	"Thread length too short"	Check thread geometry.
61127	"Gear ratio of thread drilling axis incorrectly defined (machine data)"	Check the settings in machine data 31050 and 31060.
61128	"Insertion angle = 0 when inserting with oscillation or helix"	Use greater insertion angle.
61180	"No name assigned to swivel data block although machine data \$MN_MM_NUM_TOOL_CARRIER > 1"	Assign a unique name for the swivel data block.
61181	"NCK software version not high enough (no TOOLCARRIER functionality)"	Upgrade the NCK software version.
61182	"Swiveling data block name unknown"	Check the name of the swivel data block.
61183	"Retraction mode GUD7_TC_FR outside value range 0..2"	Check swivel cycle CYCLE800 start-up.
61184	"No solution possible with currently input angle values"	Check the angle entered for swivelling the machining plane.
61185	"No or incorrect (min > max) angle ranges declared for rotary axes"	Check swivel cycle CYCLE800 start-up.
61186	"Rotary axis vectors invalid"	Check swivel cycle CYCLE800 start-up.
61188	"No axis name declared for 1st rotary axis -> check CYCLE800 start-up"	Check swivel cycle CYCLE800 start-up.
61200	"Too many elements in machining block"	Edit machining block, delete elements if necessary
61201	"Incorrect sequence in machining block"	Sort the machining block sequence
61202	"Not a technology cycle"	Program technology block.
61203	"Not a position cycle"	Program positioning block.

61204	"Unknown technology cycle"	Delete technology block and program again.
61205	"Unknown position cycle"	Delete positioning block and program again.
61210	"Block search element not found"	Repeat block search.
61212	"Incorrect tool type"	Select a new tool type
61213	"Circle radius too small"	Enter a larger value for the circle radius
61214	"No pitch programmed"	The pitch must be programmed
61215	"Blank dimension incorrectly programmed"	Check dimensions of blank spigot. blank spigot must be larger than the finished spigot.
61216	"Feed/tooth possible only for milling tools"	Alternatively, you can set another feed type
61217	"Cutting rate programmed for tool radius 0 "	Enter a cutting rate setting
61218	"Feed/tooth programmed, but number of teeth is zero"	Enter the number of teeth of the cutting tool in the "Tool list" menu
61222	"Plane infeed greater than tool diameter "	Reduce the plane infeed.
61223	"Approach path too small"	Enter a larger value for the approach path
61224	"Retract path too small"	Enter a larger value for the retract path
61225	"Swiveling data block unknown"	An attempt has been made to access an undefined swiveling data block.
61226	"Swivel head cannot be replaced"	The parameter "Swivel data block change" is set to "no". An attempt has still been made to change the swivel head.
61230	"Tool probe diameter too small"	The tool probe is not correctly calibrated.
61231	"ShopMill program cannot be executed; not yet tested by ShopMill"	The program must be simulated in ShopMill first or loaded to the "Machine Auto" mode of ShopMill.
61232	"Magazine tool cannot be loaded"	An attempt has been made to automatically load a tool into a swivel head which can hold only manual tools.
61234	"ShopMill subroutine cannot be executed; not yet tested by ShopMill"	The subroutine must be simulated in ShopMill first or loaded to the "Machine Auto" mode of ShopMill.
61301	"Probe is not responding"	<ul style="list-style-type: none"> • Check probe connections • Set a longer measuring distance via MD 9752, 9753, 9754, 9755 • For edge measurements: Position probe closer to edge • Position approximately over center of spigots/holes • Check setting for spigot/hole diameter

7.1 Cycle alarms and messages

61302	"Probe collision"	The probe has collided with an obstacle on its positioning path. <ul style="list-style-type: none"> • Check spigot diameter (it may be too small) • Check measuring path (it may be too long)
61303	"Safe area exceeded"	Result of spigot/hole diameter measurement deviates significantly from specified value. Check radius or diameter. Check measuring location (e.g. for inaccuracies caused by swarf)
61308	Check measuring path 2a	Enter measuring path = 0 Check MD 9752, 9753, 9754, 9755
61309	Check probe type	Probe type: 3D probe not active
61310	Scaling factor is active	Scaling factor = scaling is active
61311	No D number is active	No tool offset has been selected for the probe (for workpiece measurements) or for the active tool (for tool measurements).
61316	Center point and radius cannot be calculated	The system cannot calculate a circle from the measured points.
61332	Alter the tool tip position	Tool tip is positioned below the probe surface (e.g. with a setting ring gauge or cube)
61338	Positioning speed is zero	Set corresponding feedrate (plane/infeed rate) via MD 9757 or 9758
61605	"Contour incorrectly programmed"	Check the contour.
61610	"No infeed depth programmed"	The infeed depth must be programmed
62100	"No drilling cycle active"	No modal drilling cycle has been called before the drilling pattern cycle
62101	"Milling direction not correct - G3 will be generated"	Climb or conventional milling programmed, but the spindle was not rotating when the cycle was called.
62103	"No finishing allowance programmed"	Program finishing allowance.
62180	"Set rotary axes ... "	Prompt to position rotary axes manually.
62181	"Set rotary axis ... "	Prompt to position rotary axis manually.
62182	"Attach inclinable head: ..."	Prompt to attach inclinable head.
62183	"Remove inclinable head:..."	Prompt to remove inclinable head.
62184	"Replace inclinable head:..."	Prompt to replace inclinable head.
62185	"Angle adjusted to angular grid:..."	Indication that the desired angle cannot be set due to the Hirth tooth system. The displayed angle is set instead.

7.1.3 Messages in cycles



Cycles display messages in the dialog line of the control system. Messages of this type do not interrupt the machining process. Messages describe certain operational characteristics of the relevant cycle and indicate the current processing status. They are generally displayed for one processing section or until the cycle end.

7.2 Alarms for ShopMill

7.2.1 Alarm overview

Overview of alarms

If errors are detected in ShopMill, the system generates an alarm and aborts program execution if necessary.

The error text that is simultaneously displayed with the alarm number indicates the possible error cause.

100000-100999	Basic system	
101000-101999	Diagnostics	
102000-102999	Services	
103000-103999	Machine	
104000-104999	Parameters	
105000-105999	Programming	
106000-106999	Spare	
107000-107999	OEM	
110000-110999		Reserved
111000-112999	ShopMill	
120000-120999		Reserved

Danger

Please check the plant situation as indicated in the description of the alarm/s that has/have been generated. Eliminate the cause of the alarm/s and acknowledge it/them as instructed. If you fail to observe this alarm response procedure, you will endanger the machine, workpiece, stored settings and possibly your own safety.

If you are working in CNC ISO mode, please refer to alarm descriptions in the following manual:

References: /DA/, Diagnostics Guide SINUMERIK 840D/840Di/810D



7.2.2 Select the alarm/message overview



Function

You can view alarms and messages and then acknowledge them.

Operating sequence

The alarm/message overview displays all active alarms and messages with numbers, date, cancel criterion and explanation.

Cancel the alarm with the key displayed in symbol form:

Switch machine/control off and on again (main switch)
or NCK Power ON

Press the "Reset key"

Press the "Alarm cancel" key

Alarm is canceled with "Cycle Start"

Alarm is canceled with the "Return" key

7.2.3 Description of alarms

111 311	NC Start is not possible: Deselect SBL mode
Explanation	You have activated a program with block search even though SBL mode was active at the same time.
Reaction	NC Start disable Alarm display
Remedy	Interface signals are set Deselect SBL mode
112 045	More insertion points required
Explanation	The system requires more insertion points to machine the contour pocket. The machining process is divided into several individual operations. Residual material will be left on the workpiece.
Reaction	Alarm display This alarm is a warning only. The program can be started.
Remedy	If you use a smaller cutter, you may be able to perform the operation with a single insertion point.
112 046	Main contour cannot be traversed
Explanation	The pocket contour cannot be traversed with the programmed cutting tool. Residual material will be left on the workpiece.
Reaction	Alarm display This alarm is a warning only. The program can be started.
Remedy	You may be able to traverse the whole pocket contour if you use a smaller cutter.
112 052	No residual material generated
Explanation	No residual material has been generated. You may not need to remove any residual material.
Reaction	Alarm display This alarm is a warning only. The program can be started.
Remedy	No remedial action necessary.

112 057

Explanation

Programmed helix violates contour

You have selected the starting point for helical insertion such that the programmed contour is violated by the helix.

Reaction

Alarm display

This alarm is a warning only.

The program can be started.

Remedy

Select another starting point.

Use a smaller helix radius.

112 099

Explanation

System error contour pocket

An error has occurred during calculation of the contour pocket.

Reaction

Alarm display

The system cannot calculate the contour pocket.

The program cannot be started.

Remedy

Please note the error text and contact the Siemens A&D MC Hotline.

112 100

Explanation

Renumbering error.**Initial state restored**

You have selected soft key "Renumber" in the program editor. An error has occurred during renumbering which has damaged the program in the memory. The original program must now be reloaded to the memory.

Reaction

Alarm display

Program has not been renumbered.

Remedy

Create space in the memory, e.g. by deleting an old program. Select "Renumber" soft key again.

112 200

Explanation

Contour is Step in current program sequence. Processing not enabled

The selected contour is an element of the program loaded under "Program".

Reaction

Alarm display

The contour is an element from a loaded program and cannot be deleted or renamed.

Remedy

Remove contour from the loaded program.

112 201	Contour is step in current Automatic sequence. Processing not enabled
Explanation	The selected contour is an element of the program loaded under "Machine Auto".
Reaction	Alarm display The contour is an element of a program loaded under "Machine Auto" and cannot be deleted or renamed. After program start, contours included in the current program cannot be altered under "Program" while the program is running.
Remedy	Stop program run and load program under "Program". Delete contour from program.
112 210	Tool axis cannot be reselected. Insufficient NC memory.
Explanation	If you select another tool axis, you must generate a new NC program. You must save the old NC program first and then generate the new one. There is not sufficient NC memory available at this point to store the new program.
Reaction	Alarm display The new tool axis is not selected.
Remedy	You must create free space in the NC memory corresponding to at least the space required by the new program (e.g. by deleting programs you no longer need).
112 211	System unable to process tool preselection. Insufficient NC memory.
Explanation	Before a tool preselection can be processed, you must generate a new NC program. You must save the old NC program first and then generate the new one. There is not sufficient NC memory available at this point to store the new program.
Reaction	Alarm display The system does not process the tool preselection.
Remedy	You must create free space in the NC memory corresponding to at least the space required by the new program (e.g. by deleting programs you no longer need).
112 300	Tool management strategy 2 impossible. Magazine is not fully loaded
Explanation	The magazine is not fully loaded with tools. The number of tools defined in machine data 18082 must be set up in the magazine for tool management strategy 2.
Reaction	Power ON alarm
Remedy	Start-up: Set up the correct number of tools

112 301	Tool management strategy 2 impossible. Magazine is not sorted according to tool list
Explanation	The magazine list is not sorted in the same way as the tool list. The tool order in the magazine for tool management strategy 2 must be defined according to their T numbers.
Reaction	Power ON alarm
Remedy	Start-up: Define tools according to their T numbers in magazine locations
112 323	Remove inclinable head
Explanation	You are requested to remove the specified inclinable head from the spindle.
Reaction	Alarm display
	Please read the machine manufacturer's instructions.
Remedy	Remove inclinable head.
	Please read the machine manufacturer's instructions.
112 324	Attach inclinable head
Explanation	You are requested to mount the specified inclinable head in the spindle.
Reaction	Alarm display
	Please read the machine manufacturer's instructions.
Remedy	Mount inclinable head.
	Please read the machine manufacturer's instructions.
112 325	Replace inclinable head
Explanation	You are requested to replace the specified inclinable head in the spindle with a new inclinable head.
Reaction	Alarm display
	Please read the machine manufacturer's instructions.
Remedy	Replace inclinable head
	Please read the machine manufacturer's instructions.
112 326	Set inclinable head
Explanation	You are requested to set the inclinable head according to the specified data.
Reaction	Alarm display
	Please read the machine manufacturer's instructions.
Remedy	Set inclinable head.
	Please read the machine manufacturer's instructions.

112 327	Angle outside the permissible range
Explanation	The programmed machining operation cannot be performed with the inclinable head.
Reaction	Alarm display
Remedy	Press NC Start. Clamp the workpiece differently if appropriate.
112 328	Angle adjusted to angular grid
Explanation	Owing to the angular grid, the inclinable head cannot be set to exactly the specified angle.
Reaction	Alarm display
Remedy	The machining operation can continue with the set values, but will not match the programmed machining values exactly.
112 329	Set swivel head/table
Explanation	You are requested to set the swivel head/table according to the specified data.
Reaction	Alarm display
Remedy	Please read the machine manufacturer's instructions. Set swivel head/table Please read the machine manufacturer's instructions.
112 330	Set swivel table
Explanation	You are requested to set the swivel table according to the specified data.
Reaction	Alarm display
Remedy	Please read the machine manufacturer's instructions. Set swivel table Please read the machine manufacturer's instructions.
112 350	No swiveling data available
Explanation	No swiveling data sets are available.
Reaction	Alarm display
Remedy	Set up the necessary swiveling data sets (see /FBSP/, ShopMill Description of Functions)
112 360	Step not entered in program chain, since program execution is active
Explanation	The program that you want to modify is currently running in "Machine Auto" mode. You can only modify programs if they are not being machined in the "Machine Auto" operating mode at the same time.
Reaction	Alarm display
Remedy	Terminate program in "Machine Auto" mode.

112 400

Explanation

Reaction

Remedy

Not available in the tool management

The tool stipulated in the program does not exist.

Alarm display

You must create the tool before saving the data.

112 401

Explanation

Reaction

Remedy

Tool setup has failed

The system was unable to set up a tool as the tool data were being read in.

Alarm display

Check tool management.

112 420

Explanation

Reaction

Remedy

Error in inch/metric system switchover! Check all data!

Not all data have been converted for the inch/metric switchover.

Alarm display

NC Start disable

Check the following data:

- Display machine data:
 - MD9655: \$MM_CMM_CYC_PECKING_DIST
 - MD9656: \$MM_CMM_CYC_DRILL_RELEASE_DIST
 - MD9658: \$MM_CMM_CYC_MIN_COUNT_PO_TO_RAD
 - MD9664: \$MM_CMM_MAX_INP_FEED_P_MIN
 - MD9665: \$MM_CMM_MAX_INP_FEED_P_ROT
 - MD9666: \$MM_CMM_MAX_INP_FEED_P_TOOTH
 - MD9670: \$MM_CMM_START_RAD_CONTOUR_POCKET
 - MD9752: \$MM_CMM_MEASURING_DISTANCE
 - MD9753: \$MM_CMM_MEAS_DIST_MAN
 - MD9754: \$MM_CMM_MEAS_DIST_TOOL_LENGTH
 - MD9755: \$MM_CMM_MEAS_DIST_TOOL_RADIUS
 - MD9756: \$MM_CMM_MEASURING_FEED
 - MD9757: \$MM_CMM_FEED_WITH_COLL_CTRL
 - MD9758: \$MM_CMM_POS_FEED_WITH_COLL_CTRL
 - MD9759: \$MM_CMM_MAX_CIRC_SPEED_ROT_SP
 - MD9761: \$MM_CMM_MIN_FEED_ROT_SP
 - MD9762: \$MM_CMM_MEAS_TOL_ROT_SP
 - MD9765: \$MM_CMM_T_PROBE_DIAM_LENGTH_MEAS
 - MD9766: \$MM_CMM_T_PROBE_DIAM_RAD_MEAS
 - MD9767: \$MM_CMM_T_PROBE_DIST_RAD_MEAS
 - MD10240: \$MN_SCALING_SYSTEM_IS_METRIC
 - MD20150 [12]: \$MC_GCODE_RESET_VALUES
- Tool data for various cutting edges D::
 - Length Z, radius R,
 - wear lengths Z and R
- Work offsets:
 - Basic offset
 - Position in X, Y, Z and A, C (if configured)
 - Work offset
- Settings in MANUAL operating mode:
 - Return plane
 - Safety clearance

Note	This alarm can occur only in connection with hardware defects.
112 502	Insufficient memory
	Abort in line %1
Explanation	%1 = line number Program contains too many program blocks
Reaction	Alarm display Program is not loaded
Remedy	Modify program in operating area PROGRAMS CNC-ISO operator interface.
112 504	File does not exist or is faulty: %1
Explanation	%1 = Name of file/contour Program cannot interpret a program block containing contour programming. Contour does not exist in directory.
Reaction	Alarm display NC Start disable
Remedy	Load contour to directory.
112 505	Error in interpreting contour %1
Explanation	%1 = Name of contour Contour is faulty
Reaction	Alarm display NC Start disable
Remedy	Check contour machining sequence
112 506	Maximum number of contour elements exceeded %1
Explanation	%1 = Name of contour The maximum permissible number of contour elements (50) has been exceeded during interpretation of the contour machining sequence.
Reaction	Alarm display
Remedy	Check contour machining sequence, revise if necessary.
112 541	Program cannot be interpreted
Explanation	The program cannot be interpreted as a ShopMill program during loading as the program header is missing.
Reaction	Alarm display NC Start disable
Remedy	-
112 604	Link to PLC interrupted
Explanation	Checkback message to the PLC user program that the link to the PCU is interrupted.
Reaction	Alarm display ShopMill PLC is shut down
Remedy	Check the PLC user program.

112 605

Note

Reaction

Remedy

Asynchronous subroutine has not been executed

The NC has not been able to process the input values correctly.

Alarm display

Press NC Start.

112 650

Explanation

Reaction

Remedy

Unknown PLC error

The PLC has signaled an error which cannot be recognized by the operator interface.

Alarm display

NC Start disable

Press Power ON, contact Siemens.

7.3 User data



User data are variables that are used internally both by ShopMill programs and G code programs. These user data can be displayed in a list.



The following variables are defined:

- Global user data (GUD)
GUDs are valid in all programs.
GUD display can be disabled via the keyswitch or by using a password.
- Local user data (LUD)
LUDs are only valid in the program or subroutine in which they were defined.
ShopMill only shows the LUDs that are available in the execution sequence of the controller. If you press the "Cycle Stop" key, the list of LUDs is updated. The values, on the other hand, are updated continuously.
- Program global user data (PUD)
PUDs are generated from the local variables (LUD) defined in the main program.
This means that the PUDs are valid in all subroutines and can be written and read there.
Local user data are also displayed with the program global user data.
- Channel-specific user data
The channel-specific user data are only valid in one channel.

ShopMill does not display user data of type AXIS and FRAME.

For details of which variables ShopMill displays, please refer to the machine manufacturer's instruction manual.



Display user data

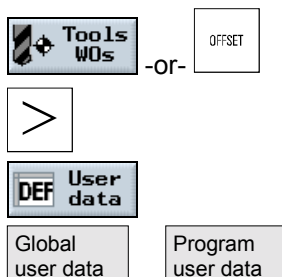

- Press the "Tools WOs" or the "Offset" key.
- Press the "Expansion" soft key.
- Press the "User data" soft key.
- Use the soft keys to select which user data you want to display.

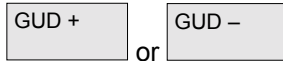

- Press the "GUD +" or "GUD -" soft key if you want to display GUD 1 to GUD 9 of the global and channel-specific user data.

Find user data

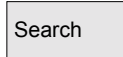

- Select soft key "Search".
- Specify the text you want to search for.
You can search for any string of characters.



- Press the "Accept" soft key.

The user data you are looking for is displayed.

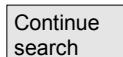

- Press the "Continue search" soft key if you want to continue the search.

The next user data with the specified character string is displayed.

7.4 Version display



Diagnostics

Service
display

Version

NCU
versionMMC
version

The ShopMill and NCU versions are given in the CNC-ISO operator interface.

The ShopMill-PLC version is given in the ShopMill Start Display.

- Switch to the CNC-ISO operator interface.
- Press the "Diagnostics" and "Service display" soft keys.
- Press the "Version" and "NCU version" soft keys.

The NCU Version is shown at the top of the window that appears:
xx.yy.zz 810D or 840D

- Press the "MMC Version" soft key.

The ShopMill Version is given in the list that appears.

PCU 50: ShopMill..... V xx.yy.zz

PCU 20: cmm.dll..... V xx.yy.zz



Examples

8.1	Example 1: Machine with rectang./circ. pocket and circumf. slot	8-322
8.2	Example 2: Shift and mirror a contour	8-330
8.3	Example 3: Chamfer on circular spigot.....	8-333
8.4	Example 4: Cylinder surface transformation	8-336
8.5	Example 5: Slot side compensation	8-340
8.6	Example 6: Swiveling	8-344

8.1 Example 1: Machine with rectang./circ. pocket and circumf. slot

Workpiece drawing

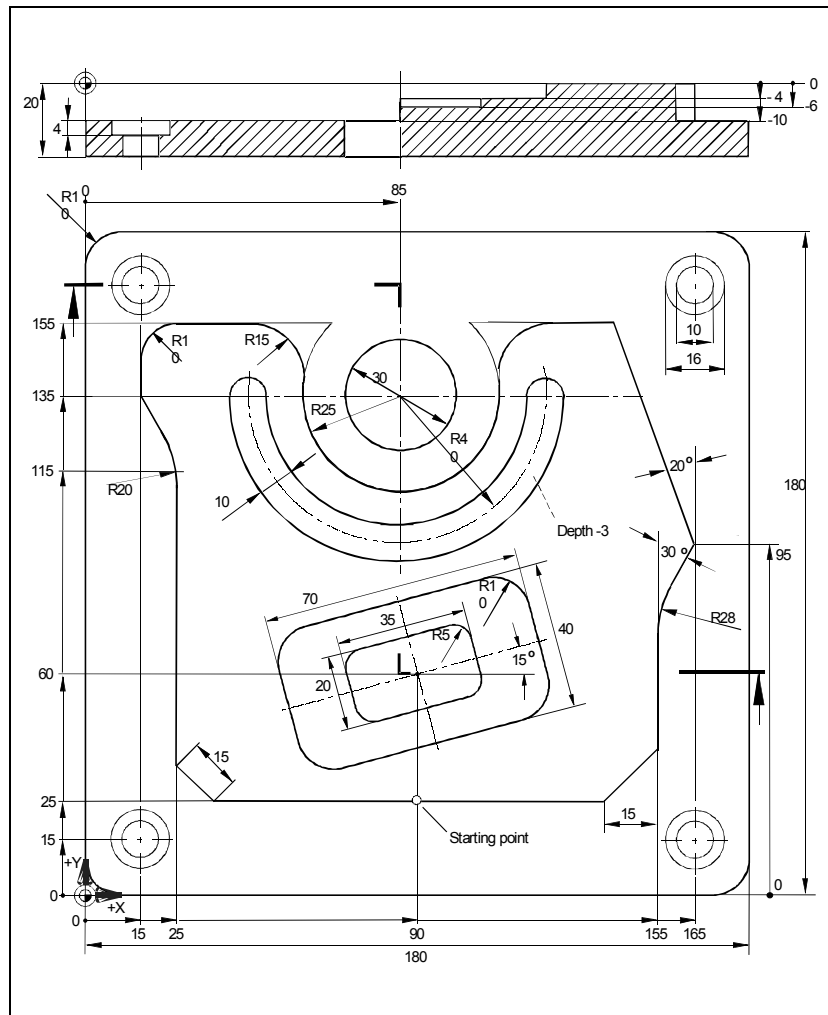

Program part_4

1. Program header

- Define a blank:

X0 0 abs	Y0 0 abs	Z0 0 abs
X1 180abs	Y1 180abs	Z1 -20abs

- Select soft key 

2. Face milling

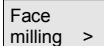
- Select via soft keys   and choose a machining strategy

- Example of technological data:

T FACING TOOL **F** 0.1mm/tooth **V** 1200 m/min

Machining Roughing

X0	0 abs
Y0	0 abs
Z0	1 abs
X1	180 abs
Y1	180 abs

8.1 Example 1: Machine with rectang./circ. pocket and circumf. slot

Z1	0 abs
DXY	80%
DZ	0.5
UZ	0

- Select soft key 

3. Outside contour of workpiece

The outside contour can be defined as a rectangular spigot as shown **here**. It is of course also possible to use the contour milling function.

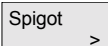
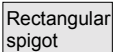
- Select via soft keys   
- Assign technological parameters T, F and S accordingly and enter the following parameters:



Position of reference point	Bottom left
Machining	▽
Position type	Single position
X0	0 abs
Y0	0 abs
Z0	0 abs
W	180 abs
L	180 abs
R	10 abs
α0	0 degrees
Z1	20 inc
DZ	20
UXY	0
UZ	0
W1	185 (fictitious blank dimension)
L1	185 (fictitious blank dimension)

- Select soft key 

4. Outside contour of island

In order to machine the entire surface outside the island, define a contour pocket around the blank and then program the island. In this way, the entire surface area is machined and no residual material is left behind.





a) Outside contour of pocket

- Select via soft keys  
- Enter a contour name (in this case: Part_4_Pocket) and confirm
- Fill in start screenform for contour



Tool axis	Z
X	-20 abs
Y	0 abs

 and confirm .
- Enter the following contour elements and confirm each with soft







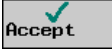









key  :

1.  X 200 abs
2.  Y 200 abs
3.  X -20 abs
4. 

a) Outside contour of island

- Select soft key 
- Select via soft keys  
- Enter a contour name (in this case: Part_4_Island) and confirm
- Fill in start screenform for contour
Tool axis Z
X 90 abs Y 25 abs
and confirm .
- Enter the following contour elements and confirm each with soft

key  :

1.  X 25 abs **FS** 15
2.  Y 115 abs **R** 20
3.  X 15 abs Y 135 abs
4.  Y 155 abs **R** 10
5.  X 60 abs **R** 15
6.  Y 135 abs **R** 20
7.   **Direction of rotation** 
R 25 **X** 110 abs
8.  
Y 155abs **R** 15
9.  **R** 0
10.  X 165 abs Y 95 abs **α1** 290 degrees **R** 0
11.  X 155 abs **α1** 240 degrees **R** 28
12.  **FS** 0
13.  X 140 abs Y 25 abs **α1** 225 degrees **R** 0

c) Mill/solid machine a contour

14.  

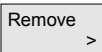
- Select via soft keys  
- Assign technological parameters T, F and S accordingly (e.g. cutter diameter 10) and enter the following parameters:

Machining	▽
Z0	0 abs
Z1	10 inc
DXY	4.5mm
DZ	10
UXY	0mm
UZ	0
Starting point	auto
Insertion	Center
FZ	0.1mm/tooth

Select lift-off mode, e.g. to retraction plane

- 

Notes:

- When selecting the milling tool, please make sure that the tool diameter is large enough to cut the intended pocket. A message will be output if you make a mistake.
- If you want to finish cut the pocket, you must assign parameters UXY and UZ accordingly and add a second solid machining cycle for finishing.

5. Mill a rectangular pocket (large)

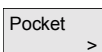
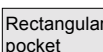
- Select via soft keys   
- Example of technological data:

T MILLTOOL10 **F** 0.1mm/tooth **V** 200m/min

Position of reference point	Center
Machining	▽
Position type	Single position
X0	90 abs
Y0	60 abs
Z0	0 abs
W	40
L	70
R	10
α0	15
Z1	4 inc
DXY	4.5mm
DZ	4
UXY	0

8.1 Example 1: Machine with rectang./circ. pocket and circumf. slot

UZ 0
Insertion Helical
EP 2
ER 2
Stock removal Complete machining

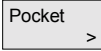
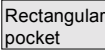

6. Mill a rectangular pocket (small)

- Select via soft keys  **Mill-ing**  Pocket >  Rectangular pocket
- Enter parameters:

X0 90 abs
Y0 60 abs
Z0 -4 abs
W 20
L 35
R 5
α0 15
Z1 4 inc
DXY 4.5mm
DZ 2
UXY 0
UZ 0
Insertion Oscillation
EW 10 degrees
Stock removal Complete machining

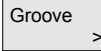
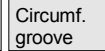

7. Mill a circumferential slot

- Select via soft keys  **Mill-ing**  Groove >  Circumf. groove
- Example of technological data:

T MILLTOOL8	F 0.5mm/tooth	FZ 0.02mm/tooth
V 150m/min		

Machining ▾
Full/pitch circle Pitch circle
X0 85 abs
Y0 135 abs
Z0 0 abs
W 10
R 40
α0 180 degrees
α1 180 degrees
α2 0 degrees
N 1
Z1 3 inc

8. Drilling/centering

DZ 3
UXY 0mm

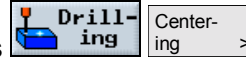

- Assign technological parameters T, F and S accordingly and enter the following parameters:

Diameter/tip Diameter
 \emptyset 16



9. Drilling/reaming

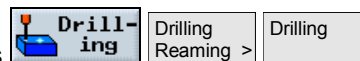

- Assign technological parameters T, F and S accordingly (e.g. DRILL10) and enter the following parameters:

Diameter/tip Tip
Z1 -25 abs
DT 0



10. Positions



- Enter parameters:

Z0 rectangular
 -10 abs
X0 15 abs
Y0 15 abs
X1 165 abs
Y1 15 abs



11. Obstacle



- Enter parameters:

Z 2 abs

**Note:**

If this obstacle cycle is not inserted, the drill will violate the right-hand corner of the island contour. Alternatively, you could increase the safety clearance.

12. Positions



-

- Enter parameters:

	rectangular
Z0	-10 abs
X2	165 abs
Y2	165 abs
X3	15 abs
Y3	165 abs



13. Mill a circular pocket

- Select via soft keys

- Example of technological data:

T MILLTOOL8	F 0.15mm/tooth	V 300m/min
--------------------	-----------------------	-------------------

- Enter parameters:

Machining	▽
Position type	Single position
X0	85 abs
Y0	135 abs
Z0	-6 abs
Diameter	30
Z1	15 inc
DXY	4
DZ	5
UXY	0mm
UZ	0
Insertion	Center
FZ	0.1mm/tooth
Stock removal	Complete machining







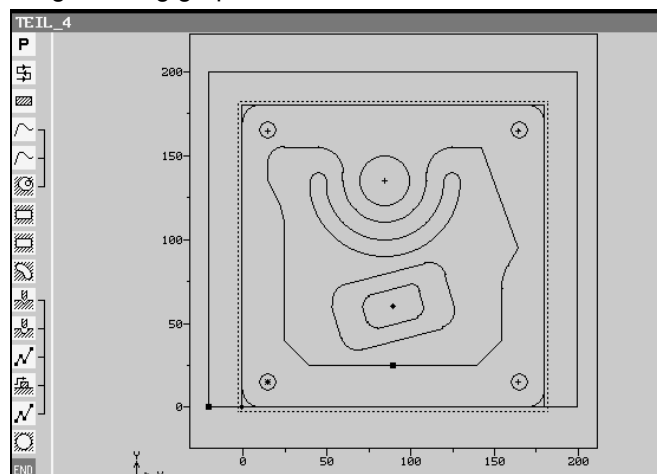









Result

- Programming graphic



- ShopMill program representation

TEIL_4			
P	NS	TEIL_4	
	N10	Face milling	T=FRAESER60 F0.2/Z S400rev. X0=0 Y0=0
	N15	Rectang.spigot	T=FRAESER60 F0.2/Z S500rev. X0=0 Y0=0
	N20	TEIL_4_TASCHE	
	N25	TEIL_4_INSEL	
	N30	Solid machin.	T=FRAESER10 F0.2/Z S300rev. Z0=0
	N35	Rectang.pocket	T=FRAESER10 F0.1/Z S200rev. X0=90 Y0=60
	N40	Rectang.pocket	T=FRAESER10 F0.1/Z S200rev. X0=90 Y0=60
	N45	Circ.slot	T=FRAESER8 F0.5/Z S150M X0=85 Y0=135
	N50	Centering	T=ZENTRIERER F300/min S300rev. ø16
	N55	DRILL	T=BOHRER10 F0.5/min S200M Z1=-25
	N60	001: Positions	Z0=-10 X0=15 Y0=15 X1=165 Y1=15
	N65	Obstacle	Z2
	N70	002: Positions	Z0=-10 X0=15 Y0=15 X1=165 Y1=15 X2=165
	N75	Circ.pocket	T=FRAESER8 F0.15/Z S300M X0=85 Y0=135
END	N80	Program end	

8.2 Example 2: Shift and mirror a contour

Workshop drawing

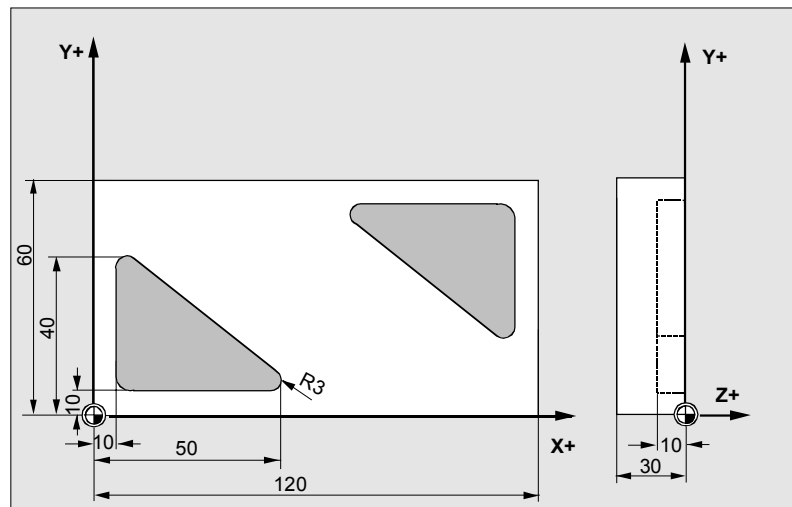

In this example, the displayed shapes occur several times in the same program. Mirroring is to be carried out in addition to the shifting operation. The shapes are to be machined with a stock removal cycle.

Program Part_1

1. Program header

- Define a blank:
Corner point: **X0** 0 abs **Y0** 0 abs **Z0** 2 abs
Dimensions: **L** 120 **W** 60 **H** -30

- Select soft key 

2. Set start marker for repetition of the contour

- Select via soft keys  

- Set start marking with "Marker1"

- 

3. Define the contour

- Select via soft keys  

- Enter a contour name (in this case: PART_1_3COR) and confirm

- Fill in start screenform for contour

Tool axis Z

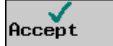

X 10 abs **Y** 10 abs

and confirm 

- Enter the following contour elements and confirm each with soft key  :

1.  **X** 60 abs **R** 3

8.2 Example 2: Shift and mirror a contour

2.  X 10 abs Y 40 abs R 3
3.  X 10 abs Y 10 abs R 3

- Select soft key 

4. Solid machining

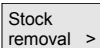

- Select via soft keys  
- Assign technological parameters T, F and S accordingly (e.g. cutter diameter 3) and enter the following parameters:

Machining	▽
Z0	0 abs
Z1	10 inc
DXY	1.5mm
DZ	2
UXY	0.5
UZ	0.5
Starting point	auto
Insertion	Center
FZ	0.1mm/tooth

Select lift-off mode, e.g. to retraction plane

- 

5. Set end marker for contour repetition

- Select via soft keys  
- Set end marking with "Marker2"

- 

6. Offset

- Select via soft keys   
- Set the following parameters:

New/additive	New
X	120
Y	60
Z	0

- 

7. Mirroring

- Select via soft keys   
- Set the following parameters:

New/additive	add
X	On
Y	On
Z	Off

8. Repetition of contour

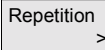
- 
- Select via soft keys  
- Set the following markers:

Start marker Marker 1
End marker Marker 2
Number of repetitions 1

- 
- Programming graphic

Result

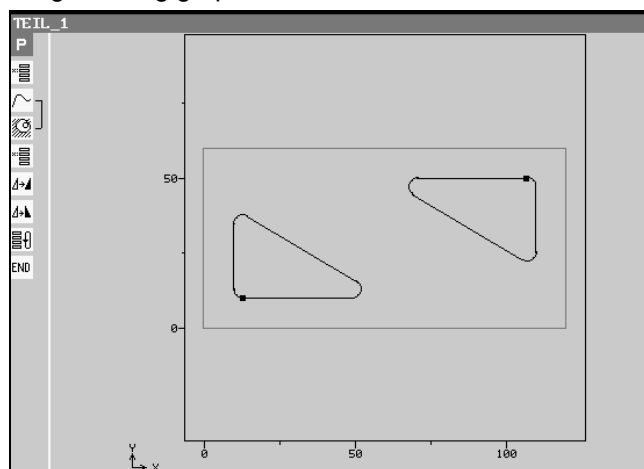

- ShopMill program representation

```

TEIL_1
P N0 TEIL_1
N5 MARKE1:
N10 TEIL_1_3ECK
N15 Solid machin. T=FRAESER3 F0.2/Z S1000rev. Z0=0
N20 MARKE2:
N30 Offset X120 Y60 Z0
N25 Mirroring add X Y
N35 Repetition MARKE1 MARKE2
END Program end

```

8.3 Example 3: Chamfer on circular spigot

Workshop drawing

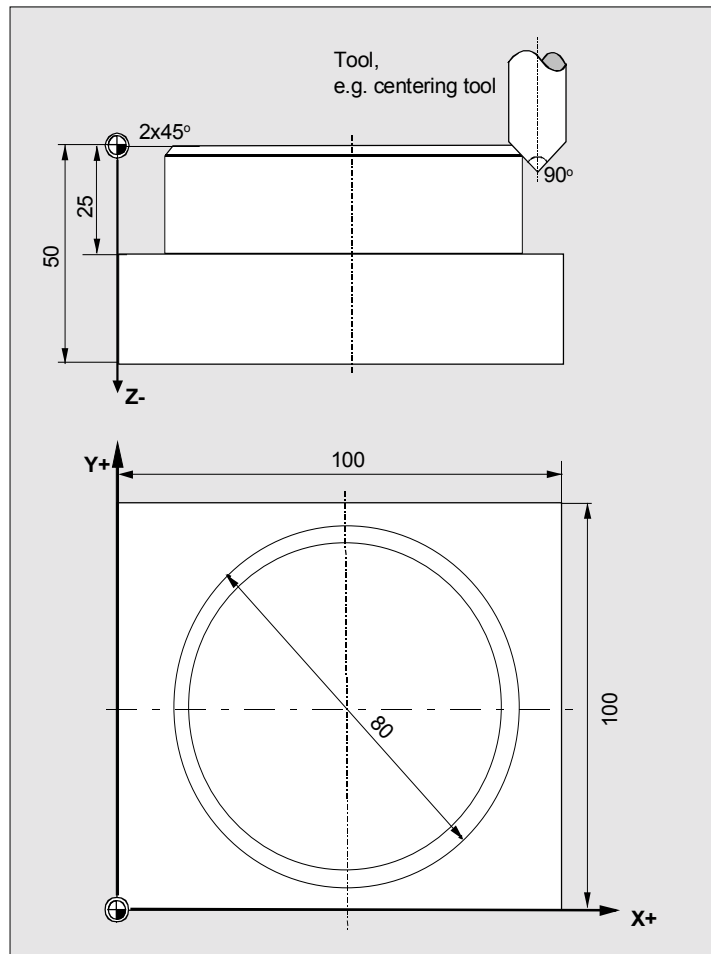

In this example, a circular spigot with chamfer (2mmx45°) is machined on a blank with a pre-machined circular spigot using a centering tool.

The general tool requirements for machining a chamfer are as follows:

- Tool diameter = 0 (e.g. centering tool)
- Tool cutting edge angle = 90°

Determining **UXY** and **Z1**:

$$Z1 \text{ (inc)} = UXY + \text{chamfer}$$

8.3 Example 3: Chamfer on circular spigot

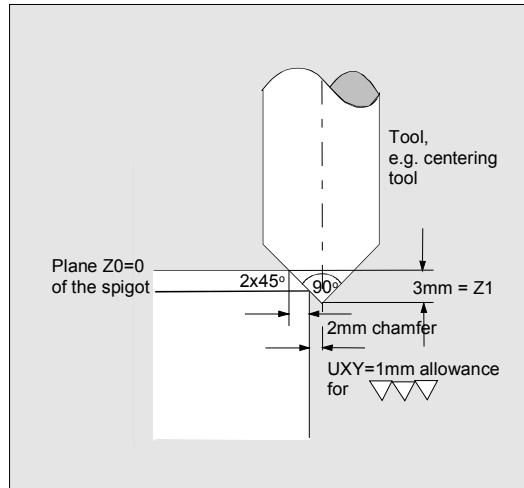

Program Part_3

1. Program header

- Define a blank:

X0 0 abs	Y0 0 abs	Z0 0 abs
X1 100abs	Y1 100abs	Z1 -50abs



- Select soft key

2. Circular spigot

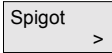
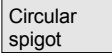
- Select via soft keys   
- Example of technological data:

T	MILLTOOL40	F 2000mm/min	V 200m/min
----------	------------	---------------------	-------------------

- Set the following parameters:

Machining	▽
Position type	Single position
X0	50 abs
Y0	50 abs
Z0	0 abs
Ø	80
Z1	25 inc
DZ	5
UXY	0mm
UZ	0.5
Ø1	100

- 

3. Circular spigot

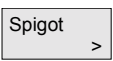
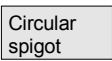
- Select via soft keys   
- Example of technological data:
T CENTERER F 2000mm/min S 200rev/min
- Set the following parameters:

Machining	▽▽▽
Position type	Single position
X0	50 abs
Y0	50 abs
Z0	0 abs
Ø	80
Z1	3 inc
DZ	10
UXY	1mm
UZ	0
Ø1	100

- 

Result

- Programming graphic

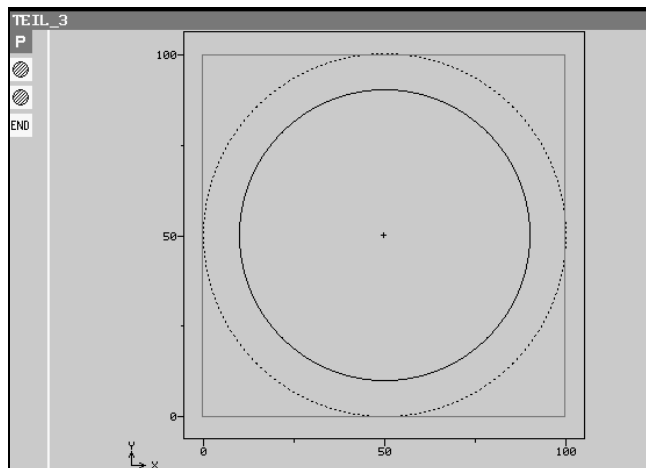

- ShopMill program representation

TEIL_3			
P	N0	TEIL_3	
	N5	Circular stud	▽ T=FRASER40 F2000/min S200M X0=50 Y0=50
	N10	Circular stud	▽▽ T=ZENTRIERER F2000/min S200rev. X0=50
END	Program end		

8.4 Example 4: Cylinder surface transformation

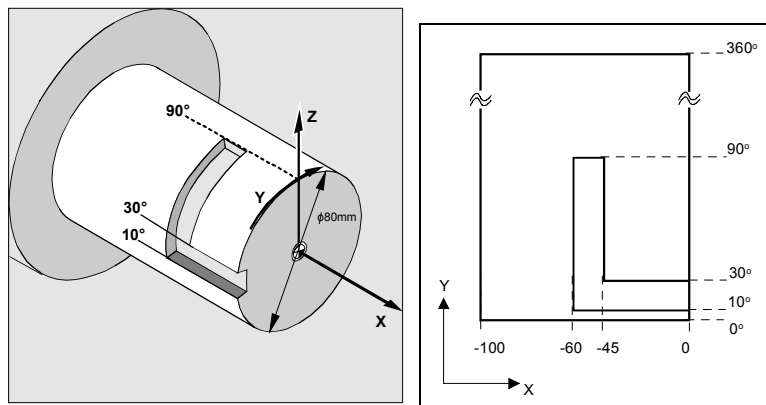

Preconditions

- There is a rotary axis, e.g. axis A, and the transformation is configured via machine data.
- The reference points on the cylinder are predefined.
Program the reference points X0, Y0, Z0 and the required work offset, for example, in "Machine Manual", "Workpiece zero" and "Edge". The work offset calculated from these is entered in the work offset list.

Program

1. Program header

- The blank dimensions correspond to the developed cylinder peripheral surface ($L = \varnothing \times \pi$).
Define a blank:
X0 0 abs **Y0** 0 abs **Z0** 40 abs
X1 -100abs **Y1** 251.327abs **Z1** 20abs **RP** 50
Note: Y1 is calculated from diameter 80 multiplied by π (3,14...)

- Select soft key 

2. Activate the work offset in the program

Select work offset for cylinder surface transformation (e.g. offset the zero point on the center point of the cylinder end face).

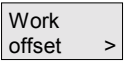











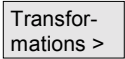
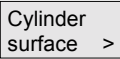

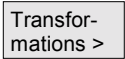
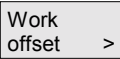
- Select via soft keys   
- Select the required work offset and then select soft key 

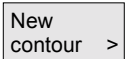
3. Position the Y axis

Position the tool in the Y axis over the center of the cylinder since the Y axis is not traversed after cylinder transformation is selected.

- Select via soft keys  

8.4 Example 4: Cylinder surface transformation

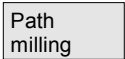
- Enter parameters:
X 10 abs **Y** 0 abs **Z** 50 abs **A** 0 abs
F *rapid traverse* mm/min **radius compensation** Off
 - Select soft key 
4. Activate cylinder peripheral surface transformation
- Select via soft keys   
 - Enter parameters:
Transformation On
 \emptyset 80
Slot side comp. OFF
 - Select soft key 
5. Activate the work offset in the program Define the work offset for the machining operation on the developed cylinder surface.
- Select via soft keys   
 - Select the required work offset and then select soft key 
6. Enter contour with contour calculator
- Select via soft keys  
 - Enter contour name and confirm
 - Fill in the contour start screen
Tool axis Z
Cylinder surface yes
 \emptyset 80
X 0 **Y α** 10abs
Note: Delete **Y** value, then enter **Y α** value (in this case 10°).
 - Enter the following contour elements and confirm each with soft key  :
1.  **X** -60 abs
2.  **Y α** 90abs
3.  **X** -45 abs
4.  **Y α** 30abs
5.  **X** 0 abs
 - Select soft key 
7. Path milling
- Select via soft keys  

- Enter parameters
T CUTTER8 **F** 0.2mm/tooth **S** 5000rev/min
Radius compensation  **Machining** ▾
Z0 40abs **Z1** 10inc **DZ** 10
UZ 0
UXY 0
Approach Linear
Depth infeed
L1 2
FZ 0,1mm/tooth
Retract Linear
Retract strategy
L2 2
Liftoff mode to return plane

Select soft key 

- Deactivate cylinder peripheral surface transformation

- Select via soft keys  **Transformations >** **Cylinder surface >**

- Enter parameters:
Transformation OFF

- Select soft key 

- Result

- Programming graphic

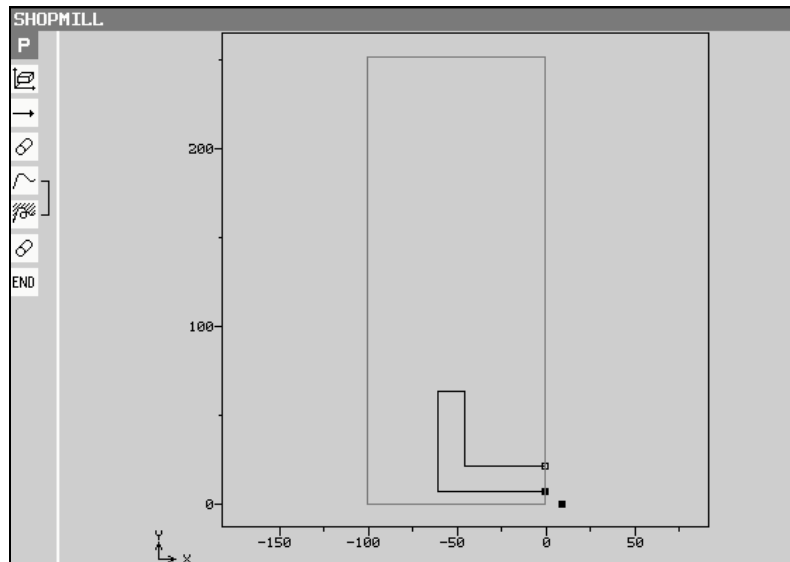

- ShopMill program representation

8.4 Example 4: Cylinder surface transformation

ZYLINDER			
P	N5	ZYLINDER	
	N10	Zero offset	1 G54
	N15	RAPID	X10 Y0 Z50
	N20	Cylind.surface	on None Groove wall compensation
	N50	Zero offset	2 G55
	N25	ZYLINDER_	
	N30	Path milling	T=CUTTER_8 F0.2/Z S5000rev. Z0=40
	N35	Cylind.surface	off
END	N40	Program end	

8.5 Example 5: Slot side compensation

A slot with parallel slot sides is milled in a pipe. In this instance, it is not the slot contour which is programmed, but the imaginary center-point path of a bolt inserted in the slot.

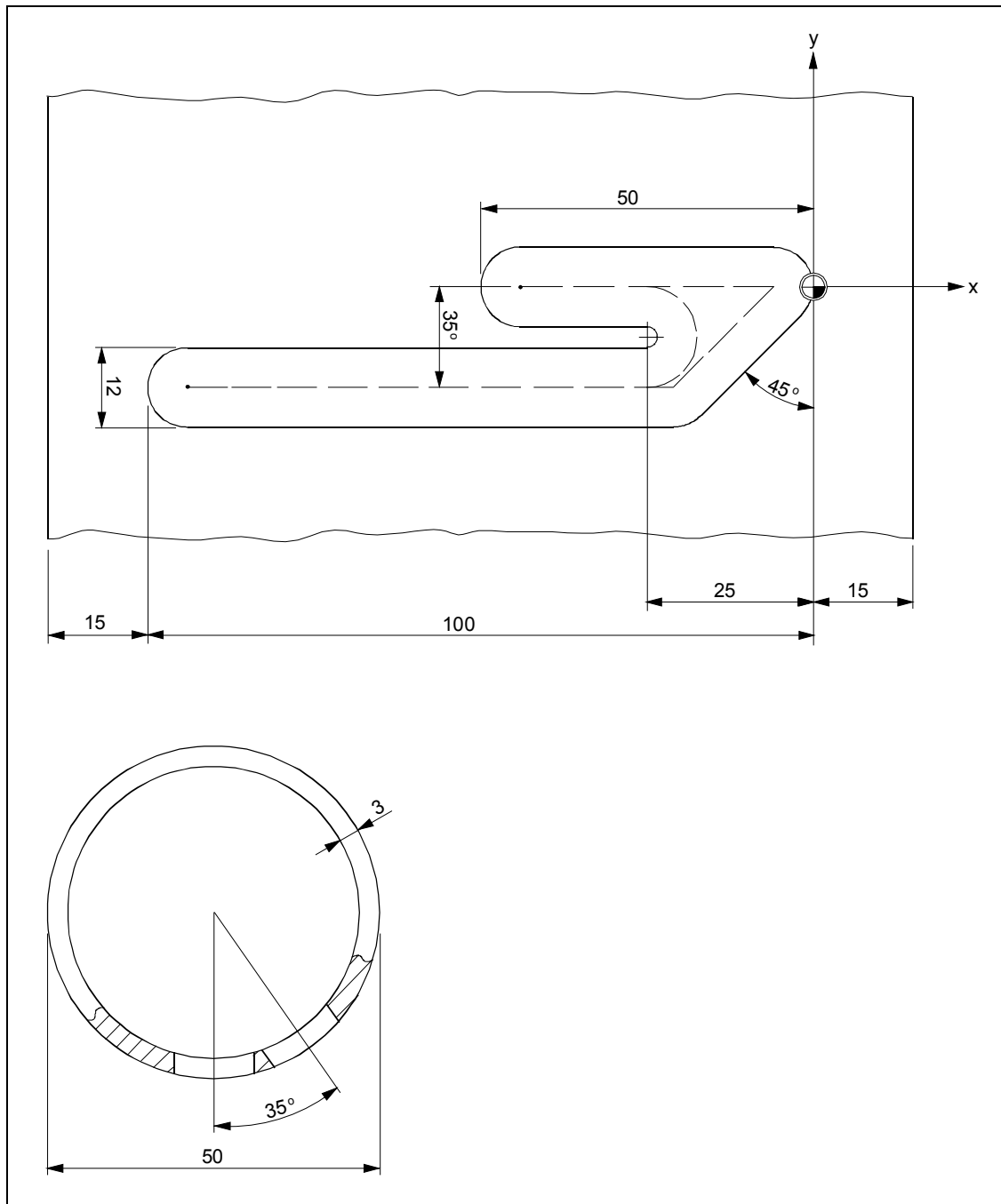

Preconditions

- There is a rotary axis, e.g. axis A, and the transformation is configured via machine data.
- The reference points on the cylinder are predefined.
Program the reference points X0, Y0, Z0 and the required work offset, for example, in "Machine Manual", "Workpiece zero" and

"Edge". The work offset calculated from these is entered in the work offset list.

Program

1. Program header

- The blank dimensions correspond to the developed cylinder peripheral surface.

X0 0 abs **Y0** 0 abs **Z0** 25 abs

X1 -130 abs **Y1** 157,08 abs **Z1** 22 abs

RP 50 **SC** 1

Note: **Y1** is calculated according to equation: $Y1 = \varnothing \pi$

In this case: Diameter 50 multiplied by 3.14...

- Select soft key 

2. Activate the work offset in the program

Select work offset for cylinder surface transformation (e.g. offset the zero point on the center point of the cylinder end face).

- Select via soft keys

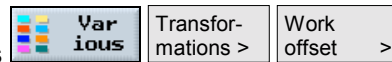

- Select the required work offset and then select soft key



3. Position the Y axis

Position the tool in the Y axis over the center of the cylinder since the Y axis is not traversed after cylinder transformation is selected.

- Select via soft keys

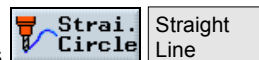

- Enter parameters:

X 10abs **Y** 0abs **Z** 40abs

F *rapid traverse*mm/min **radius compensation** OFF

- Select soft key

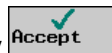

4. Activate cylinder peripheral surface transformation

- Select via soft keys

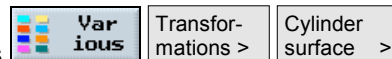

- Enter parameters:

Transformation On

∅ 50

Slot side comp. On

D 6

Note: **D** is the distance from the imaginary center-point path to the slot wall.

- Select soft key

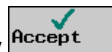

5. Activate the work offset in the program

Define the work offset for the machining operation on the developed cylinder surface (shift zero point to the zero point on the workpiece drawing).



8.5 Example 5: Slot side compensation



- Select via soft keys  Transformations > Move zero point >

Select the required work offset and then select soft key .

6. Enter contour with contour calculator



- Select via soft keys  New contour >
- Enter a contour name (in this case: cylinder) and confirm
- Fill in the contour start screen
Tool axis Z
Cylinder surface yes
 \varnothing 50 X -25 abs Y α 0 abs
Note: Delete Y value, then enter Y α value (in this case 0°).

- Select soft key 
- Enter the following contour elements and confirm each with soft key :

1.  X -44 abs
2.  X -25 abs
3.    Y α -35 abs I 0 inc
 (α 2 tang.)  β 2 180°
4.  X -94 abs
5. 
6.  X -6 abs Y α 0 abs α 1 45°
7.  X -25 abs

- Accept contour by selecting soft key .

7. Path milling

- Select via soft keys  Path milling
- Enter parameters
T CUTTER_8 **F** 0.2mm/tooth **S** 5000 rev/min
Radius compensation  **Machining** ▾
Z0 25 abs **Z1** 3 inc **DZ** 2
UZ 0 **UXY** 0
Approach Quadrant 
R1 1
FZ 0.1mm/tooth

8. Deactivate cylinder peripheral surface transformation

9. Result

Retract Quadrant 

R2 1

Liftoff mode to return plane

- Select soft key 

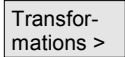
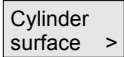
- Select via soft keys   

- Enter parameters:





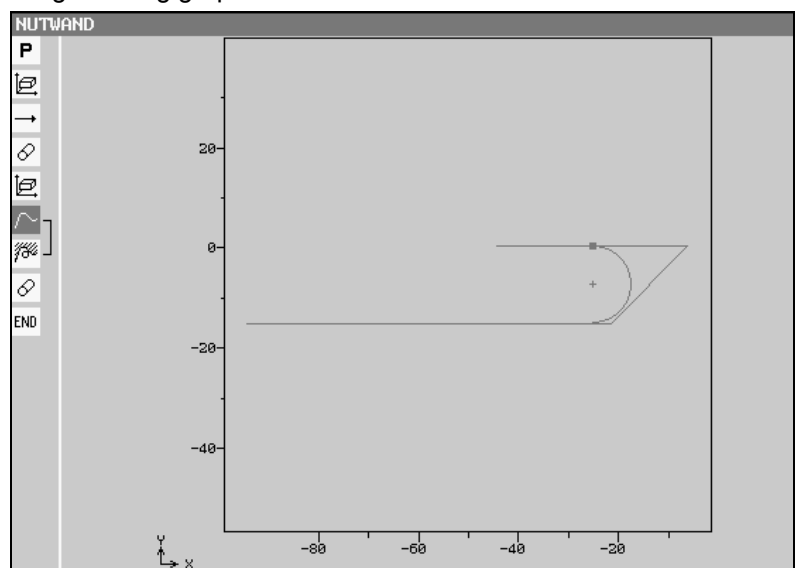

Transformation OFF

- Select soft key 

- Programming graphic



- ShopMill program representation

NUTWAND			
P	N0	NUTWAND	
	N5	Zero offset	1 G54
	N10	RAPID X10 Y0 Z40	
	N15	Cylind.surface	on wth Groove wall compensation
	N20	Zero offset	2 G55
	N25	NUTWANDKORREKT_1	
	N30	Path milling	▽ T=CUTTER_8 F0.2/Z S5000rev. Z0=25
	N35	Cylind.surface	off
END		Program end	

8.6 Example 6: Swiveling

8.6 Example 6: Swiveling

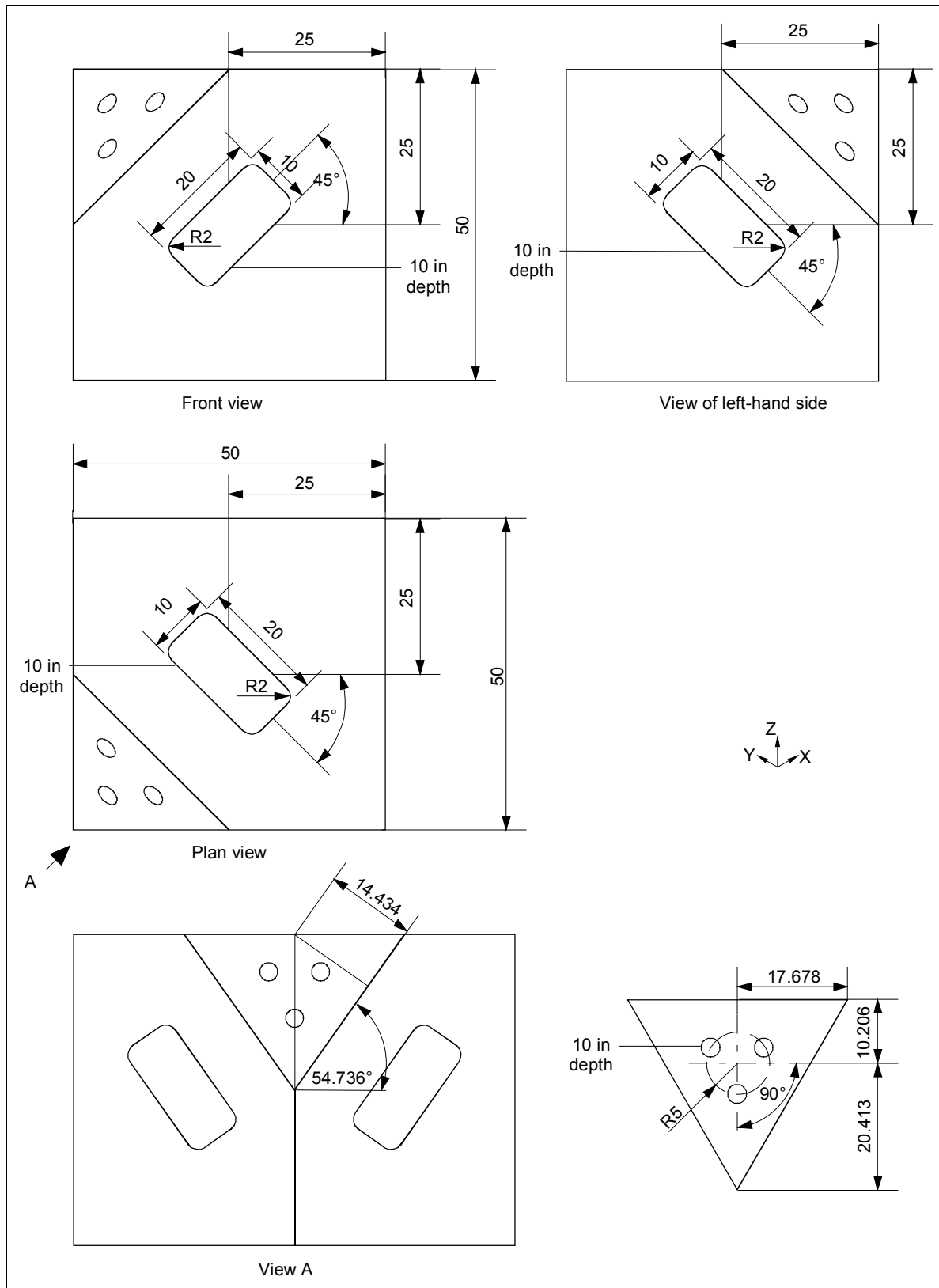

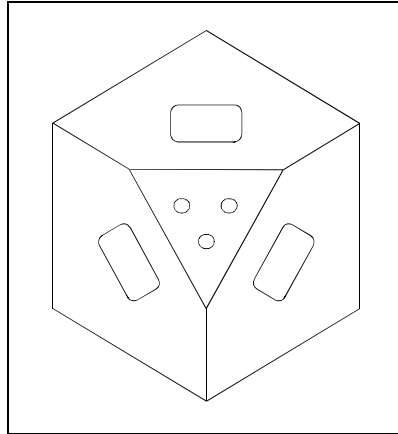

In this example, the machining plane is swiveled several times.

Program example 4

1. Program header

- Define a blank:

X0 0 abs **Y0** 0 abs **Z0** 0 abs
X1 -50abs **Y1** -50abs **Z1** -50abs

- Select soft key 

2. Rectangular pocket

- Select via soft keys   

- Example of technological data:

T CUTTER_4 **D** 1 **F** 0.1mm/tooth **V** 200 m/min

- Set the following parameters:

Position of reference point	Center
Machining type	Roughing
Position type	Single position
X0	-25 abs
Y0	-25 abs
Z0	0 abs
W	10
L	20
R	2
α0	-45°
Z1	5 inc
DXY	3mm
DZ	2.5
UXY	0mm
UZ	0
Insertion	Center
FZ	0.05mm/tooth
Stock removal	Complete mach.

- 

8.6 Example 6: Swiveling

3. Swiveling

- Select via soft keys  Transformations > Swiveling >
- Example of technological data:
T CUTTER_4 D 1
- Set the following parameters:



Retraction	Yes
Swiveling	Yes
Transformation	New
X0	0
Y0	-50
Z0	0
Swiveling	Axial
X	90°
Y	0°
Z	0°
X1	0
Y1	0
Z1	0
Direction	-
- 

4. Rectangular pocket

- Select via soft keys  Pocket > Rectang. pocket
- Example of technological data:
T CUTTER_4 D 1 F 0.1mm/tooth V 200 m/min
- Set the following parameters:

Position of ref. point	Center
Machining type	Roughing
Position type	Single position
X0	-25 abs
Y0	-25 abs
Z0	0 abs
W	10
L	20
R	2
α0	45°
Z1	5 inc
DXY	3mm
DZ	2.5
UXY	0mm
UZ	0
Insertion	Center
FZ	0.05mm/tooth
Stock removal	Complete mach.

5. Swiveling

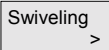
- 
- Select via soft keys  Transformations > 
- Example of technological data:
T CUTTER_4 D 1
- Set the following parameters:

Retraction	Yes
Swiveling	Yes
Transformation	New
X0	-50
Y0	-50
Z0	0
Swiveling	Axial
Z	-90°
X	90°
Y	0°
X1	0
Y1	0
Z1	0
Direction	-

- 

6. Rectangular pocket

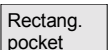
- Select via soft keys  Pocket > 
- Example of technological data:
T CUTTER_4 D 1 F 0.1mm/tooth V 200 m/min
- Set the following parameters:

Position of ref. point	Center
Machining type	Roughing
Position type	Single position
X0	-25 abs
Y0	-25 abs
Z0	0 abs
W	10
L	20
R	2
α0	-45°
Z1	5 inc
DXY	3mm
DZ	2.5
UXY	0mm
UZ	0
Insertion	Center
FZ	0.05mm/tooth

8.6 Example 6: Swiveling

7. Setting

Stock removal Complete mach.



Define a different blank so that the simulation in the visible section displays the machining of the inclined plane:



- Define a blank:

X0 -17.678 abs **Y0** 10.206 abs **Z0** 0 abs
X1 17.678 abs **Y1** -20.413 abs **Z1** -10 abs



8. Swiveling



- Example of technological data:

T FACING TOOL **D** 1

- Set the following parameters:

Retraction	Yes
Swiveling	Yes
Transformation	New
X0	-50
Y0	-50
Z0	-25
Swiveling	Axial
Z	-45°
X	54.736°
Y	0°
X1	0
Y1	20.413
Z1	0
Direction	-

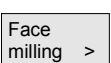

9. Face milling

- Select via soft keys   and choose a machining strategy

- Example of technological data:



T FACING TOOL **D** 1 **F** 0.1mm/tooth **V** 200 m/min

- Set the following parameters:

Machining type	Roughing
X0	-17.678 abs
Y0	-20.413 abs
Z0	14.434 abs

10. Drilling

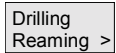
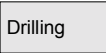

X1 17.678 abs
Y1 10.206 abs
Z1 0 abs
DXY 80%
DZ 2.5
UZ 0

- 
- Select via soft keys   
- Example of technological data:
T DRILL_3 **D** 1 **F** 0.1mm/rev **S** 2000 rev/min
- Set the following parameters:

Shank/tip Shank
Z1 5 inc
DT 0s

- 

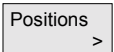
11. Position pattern

- Select via soft keys   
- Set the following parameters:

Full/pitch circle Full circle
Z0 0 abs
X0 0 abs
Y0 0 abs
α0 -90°
R 5
N 3
Positioning Linear

- 

12. Swiveling

Return swivel head or swivel table back to original position:

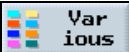
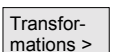
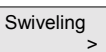
- Select via soft keys   
- Example of technological data:
T 0 **D** 1
- Set the following parameters:

Retraction Yes
Swiveling Yes
Transformation New
X0 0
Y0 0
Z0 0
Swiveling Axial

8.6 Example 6: Swiveling

X 0°
 Y 0°
 Z 0°
 X1 0
 Y1 0
 Z1 0

Direction -

Accept

Result

- ShopMill program representation

BEISPIEL4		
P	NS	BEISPIEL4
	N10	Rectang.pocket ▾ T=CUTTER_4 F0.1/Z V200M X0=-25 Y0=-25
	N15	Swivel X90 Y0 Z0 T=CUTTER_4
	N20	Rectang.pocket ▾ T=CUTTER_4 F0.1/Z V200M X0=-25 Y0=-25
	N25	Swivel Z-90 X90 Y0 T=CUTTER_4
	N30	Rectang.pocket ▾ T=CUTTER_4 F0.1/Z V200M X0=-25 Y0=-25
	N35	Setting RP25 Blank
	N40	Swivel Z-45 X54.736 Y0 T=CUTTER
	N45	Face milling ▾ T=CUTTER F0.1/Z V200M X0=-17.678
	N50	DRILL T=DRILL F0.1/rev S2000rev. Z1=5inc
	N55	001: Hole full cir. Z0=0 X0=0 Y0=0 R5 N3
	N60	Swivel T=0
END	N65	Program end

Appendix

A	Abbreviations.....	A-352
B	References.....	A-355
C	Index	A-369

A Abbreviations

ABS	Absolute dimension
CNC	Computerized Numerical Control
COM	Communication Component of the numerical control that executes and coordinates the communication
D	Edge
DIN	German Industry Standard
DRF	Differential Resolver Function: This function in combination with an electronic handwheel generates an incremental work offset in automatic mode.
DRY	Dry Run Feedrate
F	Feed
GUD	Global User Data
HW	Hardware
INC	Increment: Incremental dimension
INI	Initializing Data
LED	Light Emitting Diode
M01	M function: Programmed stop
M17	M function: Subroutine end
MCS	Machine (Machine coordinate system)
MD	Machine Data
MDI	Manual Data Input (previously MDA: Manual Data Automatic)
MLFB	Machine-readable product designation
MPF	Main Program File

NC	Numerical Control The numerical control comprises the following components NCK, PLC, PCU and COM.
NCK	Numerical Control Kernel: Component of the numerical control that executes programs and primarily coordinates the motions for the machine tool.
OP	Operator Panel
PC	Personal Computer
PCU	Personal Computer Unit: Component of the NC allowing communication between operator and machine.
PLC	Programmable Logic Controller: Component of the NC for processing control logics of machine tool.
PRT	Program Test
REF	Reference point approach function
REPOS	Reposition function
ROV	Rapid override function
RS-232	Serial Interface
S	Spindle speed
SBL	Single Block
SI	Safety Integrated
SK	Soft key
SKP	Skip block
SPF	Subprogram File
SW	Software
T	Tool
TMZ	Tool Magazine Zero
V	Cutting rate
WCS	Work (Workpiece Coordinate System)

WO

Work offset

WPD

Workpiece Directory

B References**General Documentation**

- /BU/** SINUMERIK 840D/840Di/810D/802S, C, D
Ordering Information
Catalog NC 60
Order No.: E86060-K4460-A101-A9-7600
- /IKPI/** **Catalog IK PI • 2000**
Industrial Communication and Field Devices
Order No. of bound edition: E86060-K6710-A101-A9
Order No. of single-sheet edition: E86060-K6710-A100-A9
- /ST7/** **SIMATIC**
SIMATIC S7 Programmable Logic Controllers
Catalog ST 70
Order No.: E86060-K4670-A111-A3
- /ZI/** SINUMERIK, SIROTEC, SIMODRIVE
Connections & System Components
Catalog NC Z
Order No.: E86060-K4490-A001-A8-7600

Electronic Documentation

- /CD1/** The SINUMERIK System
DOC ON CD (11.02 Edition)
(includes all SINUMERIK 840D/840Di/810D/802 and
SIMODRIVE publications)
Order No.: 6FC5 298-6CA00-0BG3

User Documentation

/AUK/	SINUMERIK 840D/810D AutoTurn Short Operating Guide Order No.: 6FC5 298-4AA30-0BP2	(09.99 Edition)
/AUP/	SINUMERIK 840D/810D AutoTurn Graphic Programming System Operator's Guide Programming/Setup Order No.: 6FC5 298-4AA40-0BP3	(02.02 Edition)
/BA/	SINUMERIK 840D/810D Operator's Guide MMC Order No.: 6FC5 298-6AA00-0BP0	(10.00 Edition)
/BAD/	SINUMERIK 840D/840Di/810D Operator's Guide HMI Advanced Order No.: 6FC5 298-6AF00-0BP2	(11.02 Edition)
/BEM/	SINUMERIK 840D/810D Operator's Guide HMI Embedded Order No.: 6FC5 298-6AC00-0BP2	(11.02 Edition)
/BAH/	SINUMERIK 840D/840Di/810D Operator's Guide HT 6 Order No.: 6FC5 298-0AD60-0BP2	(06.02 Edition)
/BAK/	SINUMERIK 840D/840Di/810D Short Operating Guide Order No.: 6FC5 298-6AA10-0BP0	(02.01 Edition)
/BAM/	SINUMERIK 810D/840D Operation/Programming ManualTurn Order No.: 6FC5 298-6AD00-0BP0	(08.02 Edition)
/BAS/	SINUMERIK 840D/810D Operation/Programming ShopMill Order No.: 6FC5 298-6AD10-0AB0	(11.02 Edition)
/BAT/	SINUMERIK 840D/810D Operation/Programming ShopTurn Order No.: 6FC5 298-6AD50-0BP2	(03.03 Edition)

/BNM/	SINUMERIK 840D840Di//810D User's Guide Measuring Cycles Order No.: 6FC5 298-6AA70-0BP2	(11.02 Edition)
/CAD/	SINUMERIK 840D/840Di/810D Operator's Guide CAD-Reader Order No.: (ist Bestandteil der Online-Hilfe)	(03.02 Edition)
/DA/	SINUMERIK 840D/840Di/810D Diagnostics Guide Order No.: 6FC5 298-6AA20-0BP3	(11.02 Edition)
/KAM/	SINUMERIK 840D/810D Short Guide ManualTurn Order No.: 6FC5 298-5AD40-0BP0	(04.01 Edition)
/KAS/	SINUMERIK 840D/810D Short Guide ShopMill Order No.: 6FC5 298-5AD30-0BP0	(04.01 Edition)
/KAT/	SINUMERIK 840D/810D Short Guide ShopTurn Order No.: 6FC5 298-6AF20-0BP0	(07.01 Edition)
/PG/	SINUMERIK 840D/840Di/810D Programming Guide Fundamentals Order No.: 6FC5 298-6AB00-0BP2	(11.02 Edition)
/PGA/	SINUMERIK 840D/840Di/810D Programming Guide Advanced Order No.: 6FC5 298-6AB10-0BP2	(11.02 Edition)
/PGK/	SINUMERIK 840D/840Di/810D Short Guide Programmierung Order No.: 6FC5 298-6AB30-0BP1	(02.01 Edition)
/PGM/	SINUMERIK 840D/840Di/810D Programming Guide ISO Milling Order No.: 6FC5 298-6AC20-0BP2	(11.02 Edition)
/PGT/	SINUMERIK 840D/840Di/810D Programming Guide ISO Turning Order No.: 6FC5 298-6AC10-0BP2	(11.02 Edition)
/PGZ/	SINUMERIK 840D840Di//810D Programming Guide Cycles Order No.: 6FC5 298-6AB40-0BP2	(11.02 Edition)

/PI/**PCIN 4.4**

Software for Data Transfer to/from MMC Module

Order No.: 6FX2 060-4AA00-4XB0 (English, French, German)

Order from: WK Fürth

/SY/

SINUMERIK 840Di

System Overview

(02.01 Edition)

Order No.: 6FC5 298-6AE40-0BP0

Manufacturer/Service Documentation**a) Lists**

/LIS/ SINUMERIK 840D/840Di/810D
SIMODRIVE 611D
Lists (11.02 Edition)
Order No.: 6FC5 297-6AB70-0BP3

b) Hardware

/BH/ SINUMERIK 840D840Di//810D
Operator Components Manual (HW) (11.02 Edition)
Order No.: 6FC5 297-6AA50-0BP2

/BHA/ SIMODRIVE **Sensor**
Absolute Encoder with PROFIBUS DP
User's Guide (HW) (02.99 Edition)
Order No.: 6SN1 197-0AB10-0YP1

/EMV/ SINUMERIK, SIROTEC, SIMODRIVE
EMC Installation Guideline (06.99 Edition)
Planning Guide (HW)
Order No.: 6FC5 297-0AD30-0BP1

/GHA/ **ADI4 - Analog Drive Interface for 4 Axes** (09.02 Edition)
Equipment Manual
Order No.: 6FC5 297-0BA01-0BP0

/PHC/ SINUMERIK 810D
Configuring Manual (HW) (11.02 Edition)
Order No.: 6FC5 297-6AD10-0AB0

/PHD/ SINUMERIK 840D
Configuring Manual NCU 561.2-573.4 (HW) (10.02 Edition)
Order No.: 6FC5 297-6AC10-0BP2

/PMH/ SIMODRIVE **Sensor**
Hollow-Shaft Measuring System SIMAG H
Configuring/Installation Guide (HW) (07.02 Edition)
Order No.: 6SN1197-0AB30-0BP1

c) Software**/FB1/**

SINUMERIK 840D/840Di/810D/FM-NC

Description of Functions, Basic Machine (Part 1) (11.02 Edition)

(the various manuals are listed below)

Order No.: 6FC5 297-6AC20-0BP2

- A2 Various Interface Signals
- A3 Axis Monitoring, Protection Zones
- B1 Continuous Path Mode, Exact Stop and Look Ahead
- B2 Acceleration
- D1 Diagnostic Tools
- D2 Interactive Programming
- F1 Travel to Fixed Stop
- G2 Velocities, Setpoint/Actual Value Systems, Closed-Loop Control
- H2 Output of Auxiliary Functions to PLC
- K1 Mode Group, Channels, Program Operation Mode
- K2 Coordinate Systems, Axis Types, Axis Configurations, Actual-Value System for Workpiece, External Zero Offset
- K4 Communication
- N2 EMERGENCY STOP
- P1 Transverse Axes
- P3 Basic PLC Program
- R1 Reference Point Approach
- S1 Spindles
- V1 Feeds
- W1 Tool Compensation

/FB2/

SINUMERIK 840D/840Di/810D

Description of Functions, Extended Functions (11.02 Edition)

(Part 2)

including FM-NC: Turning, Stepping Motor

(the various manuals are listed below)

Order No.: 6FC5 297-6AC30-0BP2

- A4 Digital and Analog NCK I/Os
- B3 Several Operator Panels and NCUs
- B4 Operation via PG/PC
- F3 Remote Diagnostics
- H1 Jog with/without Handwheel
- K3 Compensations
- K5 Mode Groups, Channels, Axis Replacement
- L1 FM-NC Local Bus
- M1 Kinematic Transformation
- M5 Measurements
- N3 Software Cams, Position Switching Signals
- N4 Punching and Nibbling
- P2 Positioning Axes

P5 Oscillation
 R2 Rotary Axes
 S3 Synchronous Spindles
 S5 Synchronized Actions (SW 3 and lower, higher /FBSY/)
 S6 Stepper Motor Control
 S7 Memory Configuration
 T1 Indexing Axes
 W3 Tool Change
 W4 Grinding

/FB3/

SINUMERIK 840D/840Di/810D

Description of Functions Special Functions (Part 3) (11.02 Edition)

(the various manuals are listed below)

Order No.: 6FC5 297-6AC80-0BP2

F2 3-Axis to 5-Axis Transformation
 G1 Gantry Axes
 G3 Cycle Times
 K6 Contour Tunnel Monitoring
 M3 Coupled Axes and ESR (previously Coupled Motion and Master/Slave Couplings)
 S8 Constant Workpiece Speed for Centerless Grinding
 T3 Tangential Control
 TE0 Installation and Activation of Compile Cycles
 TE1 Clearance Control
 TE2 Analog Axis
 TE3 Speed/Torque Coupling Master-Slave
 TE4 Transformation Package Handling
 TE5 Setpoint Exchange
 TE6 MCS Coupling
 TE7 Retrace Support
 TE8 Unlocked Path-Synchronous Switching Signal Output
 V2 Preprocessing
 W3 3D Tool Radius Compensation

/FBA/

SIMODRIVE 611D/SINUMERIK 840D/810D

Description of Functions, Drive Functions (11.02 Edition)

(the various sections are listed below)

Order No.: 6SN1 197-0AA80-0BP9

DB1 Operational Messages/Alarm Reactions
 DD1 Diagnostic Functions
 DD2 Speed Control Loop
 DE1 Extended Drive Functions
 DF1 Enable Commands
 DG1 Encoder Parameterization
 DL1 Linear Motor MD

DM1 Calculation of Motor/Power Section Parameters and Controller Data
 DS1 Current Control Loop
 DÜ1 Monitors/Limitations

/FBAN/ SINUMERIK 840D/SIMODRIVE 611 DIGITAL
 Description of Functions **ANA-MODULE** (02.00 Edition)
 Order No.: 6SN1 197-0AB80-0BP0

/FBD/ SINUMERIK 840D
 Description of Functions **Digitizing** (07.99 Edition)
 Order No.: 6FC5 297-4AC50-0BP0

DI1 Start-Up
 DI2 Scanning with Tactile Sensors (scancad scan)
 DI3 Scanning with Lasers (scancad laser)
 DI4 Milling Program Generation (scancad mill)

/FBDN/ SINUMERIK 840D/810D
 IT Solutions
NC Data Management Server (DNC NT-2000)
 Description of Functions (01.02 Edition)
 Order No.: 6FC5 297-5AE50-0BP2

/FBDT/ SINUMERIK 840D/840Di/810D
 IT-Solutions
SinDNC Data Transfer via Network
 Description of Functions (09.02 Edition)
 Order No.: 6FC5 297-5AE70-0BP0

/FBFA/ SINUMERIK 840D/840Di/810D
ISO Dialects for SINUMERIK (11.02 Edition)
 Description of Functions
 Order No.: 6FC5 297-6AE10-0BP3

/FBFE/ SINUMERIK 840D/810D
 Description of Functions **Remote Diagnostics** (11.02 Edition)
 Order No.: 6FC5 297-0AF00-0BP2

/FBH/ SINUMERIK 840D/840Di/810D
HMI Programming Package (11.02 Edition)
 Order No.: (is part of the SW delivery)

Part 1 User's Guide
 Part 2 Description of Functions

/FBHLA/ SINUMERIK 840D/SIMODRIVE 611 digital
 Description of Functions **HLA Module** (04.00 Edition)
 Order No.: 6SN1 197-0AB60-0BP2

/FBMA/	SINUMERIK 840D/810D Description of Functions ManualTurn (08.02 Edition) Order No.: 6FC5 297-5AD50-0BP2
/FBO/	SINUMERIK 840D/810D Configuring of OP 030 Operator Interface (09.01 Edition) Description of Functions (the various sections are listed below) Order No.: 6FC5 297-6AC40-0BP0 BA Operator's Guide EU Development Environment (Configuring Package) PS Online only: Configuring Syntax (Configuring Package) PSE Introduction to Configuring of Operator Interface IK Screen Kit: Software Update and Configuration
/FBP/	SINUMERIK 840D Description of Functions C-PLC Programming (03.96 Edition) Order No.: 6FC5 297-3AB60-0BP0
/FBR/	SINUMERIK 840D/810D IT-Solutions Computer Link (SinCOM) (09.01 Edition) Description of Functions Order No.: 6FC5 297-6AD60-0BP0 NFL Host Computer Interface NPL PLC/NCK Interface
/FBSI/	SINUMERIK 840D/SIMODRIVE Description of Functions SINUMERIK Safety Integrated (09.02 Edition) Order No.: 6FC5 297-6AB80-0BP1
/FBSP	SINUMERIK 840D/810D Description of Functions ShopMill (11.02 Edition) Order No.: 6FC5 297-6AD80-0BP1
/FBST/	SIMATIC FM STEPDRIVE/SIMOSTEP (01.01 Edition) Description of Functions Order No.: 6SN1 197-0AA70-0YP4
/FBSY/	SINUMERIK 840D/810D Description of Functions Synchronaktionen (10.02 Edition) Order No.: 6FC5 297-6AD40-0BP2
/FBT/	SINUMERIK 840D/810D Description of Functions ShopTurn (03.03 Edition) Order No.: 6FC5 297-6AD70-0BP2

/FBTC/	SINUMERIK 840D/810D IT-Solutions SINUMERIK Tool Data Communication SinTDC (01.02 Edition) Description of Functions Order No.: 6FC5 297-5AF30-0BP0
/FBTD/	SINUMERIK 840D/810D IT-Solutions Tool Information System (SinTDI) with Online Help (02.01 Edition) Description of Functions Order No.: 6FC5 297-6AE00-0BP0
/FBU/	SIMODRIVE 611 universal/universal E (02.02 Edition) Closed-Loop Control Component for Speed Control and Positioning Description of Functions Order No.: 6SN1 197-0AB20-0BP5
/FBW/	SINUMERIK 840D/810D Description of Functions Tool Management (10.02 Edition) Order No.: 6FC5 297-6AC60-0BP1
/FBWI/	SINUMERIK 840D/840Di/810D Description of Functions WinTPM (02.02 Edition) Order No.: This document is part of the software
/HBA/	SINUMERIK 840D/840Di/810D Manual @Event (03.02 Edition) Order No.: 6AU1900-0CL20-0AA0
/HBI/	SINUMERIK 840Di Manual (09.02 Edition) Order No.: 6FC5 297-6AE60-0BP1
/INC/	SINUMERIK 840D840Di//810D Commissioning Tool SINUMERIK SinuCOM NC (02.02 Edition) System Description Order No.: (an integral part of the online Help for the start-up tool)
/PAP/	SIMODRIVE Sensor (02.99 Edition) Absolute Encoder with PROFIBUS DP User's Guide Order No.: 6SN1197-0AB10-0YP1

/PFK/	SIMODRIVE Planning Guide 1FT5/1FT6/1FK6 Motors (12.01 Edition) AC Servo Motors for Feedrate and Main Spindle Drives Order No.: 6SN1 197-0AC20-0BP0
/PJE/	SINUMERIK 840D/810D HMI Embedded Configuring Package (08.01 Edition) Description of Functions: Software Update, Configuration, Installation Order No.: 6FC5 297-6EA10-0BP0 (the document PS Configuring Syntax is supplied with the software and available as a pdf file)
/PJFE/	SIMODRIVE Planning Guide (09.01 Edition) Built-In Synchronous Motors 1FE1 Three-Phase AC Motors for Main Spindle Drives Order No.: 6SN1 197-0AC00-0BP1
/PJLM/	SIMODRIVE Planning Guide Linear Motors 1FN1, 1FN3 (11.01 Edition) ALL General Information about Linear Motors 1FN1 1FN1 Three-Phase Linear Motor 1FN3 1FN3 Three-Phase Linear Motor CON Connections Order No.: 6SN1 197-0AB70-0BP2
/PJM/	SIMODRIVE Plannig Guide Motors (11.00 Edition) Three-Phase AC Motors for Feed and Main Spindle Drives Order No.: 6SN1 197-0AA20-0BP5
/PJTM/	SIMODRIVE Plannig Guide (08.02 Edition) Integrated Torque Motors 1FW6 Order No.: 6SN1 197-0AD00-0BP0
/PJU/	SIMODRIVE 611 Plannig Guide Inverters (08.02 Edition) Order No.: 6SN1 197-0AA00-0BP6
PMS	SIMODRIVE Plannig Guide ECO Motor Spindle (04.02 Edition) for Main Spindle Drives Order No.: 6SN1 197-0AD04-0BP0

/POS1/	SIMODRIVE POSMO A User's Guide Distributed Positioning Motor on PROFIBUS DP Order No.: 6SN2 197-0AA00-0BP3	(08.02 Edition)
/POS2/	SIMODRIVE POSMO A Installation Instructions (enclosed with POSMO A)	
/POS3/	SIMODRIVE POSMO SI/CD/CA Operator's Guide Distributed Servo Drive Systems Order No.: 6SN2 197-0AA20-0BP3	(08.02 Edition)
/PPH/	SIMODRIVE Planning Guide 1PH2/1PH4/1PH7 Motors AC Induction Motors for Main Spindle Drives Order No.: 6SN1 197-0AC60-0BP0	(12.01 Edition)
/PPM/	SIMODRIVE Planning Guide Hollow-Shaft Motors Hollow-Shaft Motors for Main Spindle Drives 1PM4 and 1PM6 Order No.: 6SN1 197-0AD03-0BP0	(10.01 Edition)
/S7H/	SIMATIC S7-300 - Manual: CPU Data (Hardware) - Reference Manual: Module Data Order No.: 6ES7 398-8AA03-8AA0	(10.98 Edition)
/S7HT/	SIMATIC S7-300 Manual STEP 7, Fundamentals, V. 3.1 Order No.: 6ES7 810-4CA02-8AA0	(03.97 Edition)
/S7HR/	SIMATIC S7-300 Manual STEP7, Reference Manuals, V3.1 Order No.: 6ES7 810-4CA02-8AR0	(03.97 Edition)
/S7S/	SIMATIC S7-300 FM 353 Stepper Drive Positioning Module Order in conjunction with configuring package	(04.97 Edition)
/S7L/	SIMATIC S7-300 FM 354 Positioning Module for Servo Drive Order together with configuring package	(04.97 Edition)

/S7M/ **SIMATIC S7-300**
FM 354 Positioning Module for Servo Drive (04.97 Edition)
Order together with configuring package

/SP/ **SIMODRIVE 611-A/611-D**
SimoPro 3.1
Program for Configuring Machine-Tool Drives
Order No.: 6SC6 111-6PC00-0AA□
Order from: WK Fürth

**d) Installation
and Start-Up**

/IAA/ **SIMODRIVE 611A**
Installation and Start-Up Guide (10.00 Edition)
Order No.: 6SN 1197-0AA60-0BP6

/IAC/ SINUMERIK 810D
Installation and Start-Up Guide (03.02 Edition)
(including description of SIMODRIVE 611D start-up
software)
Order number: 6FC5 297-6AD20-0BP0

/IAD/ SINUMERIK 840D/SIMODRIVE 611D
Installation and Start-Up Guide (11.02 Edition)
(including description of SIMODRIVE 611D start-up software)
Order number: 6FC5 297-6AB10-0BP2

/IAM/ SINUMERIK 840D/840Di/810D
HMI/MMC Installation and Start-Up Guide (11.02 Edition)
Order number: 6FC5 297-6AE20-0BP2

AE1 Updates/Options
BE1 Expand the operator interface
HE1 Online Help
IM2 Start-Up HMI Embedded
IM4 Start-Up HMI Advanced
TX1 Setting Foreign Language Texts

C Index**3**

3D representation 5-261

3D tools 2-105

3-plane view 5-259

A

Absolute dimension 1-44

Absolute dimensioning 3-129

Additional commands 3-145

Alarms

 Cycles 7-302

 ShopMill 7-310

 ShopMill 7-308

Allowance 3-142

Alternat. 3-137

Angle for tapered milling tools 2-106

Annular slot 3-214

Approach a cycle 3-137

Approach mode 3-153

Approach strategy 3-154

Arithmetic parameters 4-252

Automatic mode 2-86

Auxiliary function 2-87

Axes 3-129

Axis

 Position 2-83

Axis key 1-25

B

Basic angle of rotation 3-190

Basic block display 2-99

Basic offset 2-62

Blank 3-134

Blank dimensions 5-257

Block search 2-91

Boring 3-179

Broken-line graphics 1-37

C

Calibrate electronic measuring tool 2-74

Calibrate measuring tool 2-74

Centering 3-157

Centering 3-175

Center-point path 3-154

Chaining 3-132

Chamfer 3-146

Change the tool type 2-115

Change view 5-261

Channel status 1-31

Channel status messages 1-31

Chip breaking 3-177

Circle 3-149

 Polar 3-172

 With known center point 3-167

 With known radius 3-168

Circular pocket 3-204

Circular spigot 3-209

Circumferential slot 3-214

CNC ISO operation 2-125

Coarse offset 2-120

Complete machining 3-137

Contour

 Close 3-148

 copy 3-140

 New 3-144

 rename 3-141

Contour element 3-148

 change 3-148

 delete 3-148

Contour milling 3-143

Coolant 2-111, 3-239

Coordinate system

 Rectangular 1-42

Coordinate transformation 2-119

 define 3-228

Corner point 3-134

Create tool wear data 2-112

Cutter radius compensation 3-130

Cutting edge 3-142

Cutting plane 5-262

Cutting rate 3-130, 3-142

Cycle support 4-244

Cylinder peripheral surface transformation 3-147,
3-231

D

D 3-142

Deep-hole drilling 3-177

Define the starting point 3-144

Dialog line 1-30

Dialog selection 3-147
Direction of spindle rotation 3-239
Directory
 Copy 6-274, 6-293
 Create 6-272, 6-291
 Delete 6-275, 6-295
 Move 6-294
 Open 6-266, 6-284
 Rename 6-275, 6-294
 Select 6-266, 6-284
Disable magazine location 2-114
DR 3-142
Drill and thread milling 3-184
Drilling 3-174, 3-176
Duplo number 2-102
E
Emergency Stop 1-24
End 4-251
Equidistant path 2-110
Error log 6-279, 6-298
Example
 Cylinder peripheral surface transformation
 8-336
 Drilling 3-195
 Face milling 3-199
 Free contour programming 3-150
 Polar coordinates 3-173
 Position pattern for milling 3-217
 Rectangular pocket 3-203
 Slot side compensation 8-340
 swiveling 3-237
 Swiveling 8-344
 Thread cutting 3-183
Examples 8-322, 8-330, 8-333
Execute 2-86
Execution
 stop 2-89
F
Face milling 2-83, 3-197
Feed status 1-31
Feedrate 3-131, 3-136
Feedrate override 1-26
Fine offset 2-120
Finish 3-162
Finishing 2-83, 3-137
Fixed location 2-113
Floppy disk 6-271
Floppy disk drive 6-289
Free contour programming 3-143, 3-144

G
G code 3-145
 cut 4-250
 in ShopMill program 3-240
 insert 4-250
 search 4-250
 select 4-249
 skip 2-94
G code block
 number 4-251
G code editor 4-249
G code program
 create 4-244
 execute 4-247
 Execute 6-271, 6-289
 simulate 4-247
G code: 4-250
G function 2-87
Gear stage 3-239
Gear stage 2-60
H
H function 2-87
H number 2-102, 4-253
Hard disk 6-289
Helix 3-169
Help display 1-39
I
Inch/metric 3-129
Inch/metric switchover 1-46
inch/mm 2-61
Increment 2-55
Incremental dimension 1-44
Incremental dimensioning 3-129
Input field 1-40
Insert mode 1-41
Insertion 3-201
Inside contour 3-146
Inside thread 3-181
ISO dialect 2-102, 4-253
J
Jog 1-24
K
Keys 1-22
 operation 1-32
Keyswitch 1-27
L
Lateral offset 2-78, 3-221
Length allowance 2-112

- Line 3-165
 - Polar 3-171
- Location assignment 2-103
- Location number 2-102
- Longitudinal offset 2-78, 3-221
- Longitudinal slot 3-212
- M**
- M function 2-87
- M functions 3-239
- Machine control panel 1-24
- Machine coordinate system 1-47
- Machining
 - start 2-89
 - stop 2-89
- Machining direction 3-135
- Machining feedrate 3-131
- Machining plan 1-37
- Machining plane 2-60
- Magazine 2-114
- Magazine list 2-114
- Main program 3-223
- Manual mode 2-55, 2-82
- Manual mode 2-55
- Manual tools 2-107
- Marker 3-224
- MCS/WCS 1-47
- MDI mode 2-85
- Measure
 - workpiece zero 2-64, 3-219
- Measure corner 2-66, 2-70
- Measure hole 2-67, 2-72
- Measure spigot 2-68, 2-73
- Measurements 3-219
- Measuring
 - tools 2-76
- Measuring edge 2-65, 2-69
- Measuring probe
 - calibrate 3-222
 - Calibrate 2-81
- Messages
 - Cycles 7-307
- Metric/inch 3-129
- Metric/inch switchover 1-46
- Milling 3-197
- Mini handheld unit 1-28
- Mirroring 3-229
- Miscellaneous functions 3-239
- mm/inch 2-61
- Multiple clamping 6-268, 6-286
- N**
- Network drive 6-271, 6-289
- No. of loadings 2-113
- Number of teeth 2-111
- O**
- Obstacle 3-193
- Offset values 2-110
- Online help 4-244
- Operation 1-32
- Operator panel
 - keys 1-22
 - OP 010 1-19
 - OP 010C 1-20
 - OP 010S 1-20
 - OP 012 1-21
 - OP 015 1-21
- Operator panels 1-19
- Outside contour 3-145
- Outside thread 3-181
- P**
- Parameter
 - accept 1-41
 - calculate 1-41
 - delete 1-41
 - edit 1-41
- Parameter screen 1-38
- Parameters 3-147
 - select 1-40
 - setting 1-40
- Password 1-27
- Path milling 3-143, 3-153
- Plan view 5-258
- Plane designations 1-42
- Pocket calculator 1-45
- Pocket with islands 3-143, 3-159, 3-162
- Polar coordinates 1-43, 3-170
- Pole 3-170
- Position
 - Freely programmable 3-187
- Position
 - Repeat 3-194
- Position pattern
 - Full circle 3-190
 - Line 3-188
 - Matrix 3-189
 - Milling 3-216
 - Pitch circle 3-192
- Position value 2-62
- Positioning 3-186

- Positioning motions 3-164
- Power ON 7-309
- Prewarning limit 2-113
- Probe 2-78
- Program
 - abort 2-89
 - Copy 6-274, 6-293
 - Correct 2-100
 - Create 6-272, 6-291
 - Delete 6-275, 6-295
 - Execute 6-268, 6-276, 6-285
 - Execute a trial run 2-98
 - Interrupt 2-90
 - Load 6-289
 - Move 6-294
 - new 3-133
 - Read in 6-278, 6-297
 - Read out 6-277, 6-296
 - Rename 6-275, 6-294
 - Select for execution 2-88
 - Select several 6-273, 6-292
 - start 2-89
 - stop 2-89
- Program block 3-132
 - change 3-138
 - copy 3-140
 - cut 3-140
 - insert 3-140
 - New 3-136
 - number 3-141
 - repeat 3-224
 - search 3-141
 - select 3-140
- Program control 1-31
- Program editor 3-139
- Program header 3-132, 3-133
- Program management
 - PCU 20 6-265
 - PCU 50 6-282
- Program Manager 6-265, 6-282
- Program name 3-133
- Program structure 3-132
- Program: 2-95, 6-267, 6-284, 6-288
- Programmed stop 2-94, 3-239
- Programming graphic 1-37, 3-146
- Protection levels 1-27
- Punched tape/ISO format 4-253
- R**
- Radii allowance 2-112
- Radius 3-146
- Rapid traverse 2-83
- Rapid traverse override 1-26
- Read in tool data 6-279, 6-298
- Read in zero point data 6-279, 6-298
- Reaming 3-176
- Reapproach contour 2-90
- Recompile 4-245, 4-246
- Rectangular pocket 3-200
- Rectangular spigot 3-207
- Reference point approach 2-52
- Remote diagnosis 2-126
- Remove residual material 3-144
- Repeat 3-224
- Replacement tool 2-107
- Repos 2-90
- Reset 1-24
- Residual material 3-160
- Retract from contour 2-90
- Retraction mode 3-153
- Retraction strategy 3-154
- Retraction with position patterns 3-135
- Return plane 2-82, 3-134
- Right-hand rule 1-42
- Rotation 3-228
- Rough cut 3-159
- Rough drilling 3-156, 3-157
- Rough-drilling 3-143
- Roughing 2-83, 3-137
- Rounding radius 2-106
- RS-232 interface 6-276, 6-296
- S**
- S 3-142
- S1 1-30
- S2 1-30
- S3 1-30
- Safety clearance 2-82, 3-134
- Safety Integrated 2-54
- Save tool data 6-279, 6-298
- Save zero point data 6-279, 6-298
- Scale 2-123
- Scaling 3-229
- Screen keys 1-31
- Search
 - block 2-92
 - text 2-93
- Select the alarm overview 7-309
- Select the message overview 7-309
- Settings

- change 3-226
- Setup feedrate 2-55
- ShopMill 1-18
 - select 2-125
- ShopMill Open 2-126
- ShopMill program 3-129
- Simulation 5-256
 - Abort 5-257
 - Start 5-256
- Simultaneous recording
 - before machining 2-96
 - during machining 2-97
- Single block 2-98
 - Deselect 2-98
 - fine 2-98
- Skip 2-94
- Slot side compensation 3-231
- Soft key
 - Accept 1-35
 - Back 1-35
 - Cancel 1-35
 - OK 1-35
 - operation 1-32
- Solid machine 3-159
- Special function
 - Tool 2-111
- Special functions 2-60
- Spindle
 - Position 2-59
 - start 2-59
 - stop 2-59
- Spindle direction of rotation 2-111
- Spindle override 1-26
- Spindle position 3-239
- Spindle speed 2-59, 3-142
- Spindle speed 3-130
- Spindle status 1-31
- Start 4-251
- Stock removal 3-177
- Stop 3-239
- Straight line 3-149
 - radius compensation 3-165
- Submode 1-31
- Subroutine 3-223
- Support for measuring cycles 4-244
- Switch OFF 2-51
- Switch ON 2-51
- Swiveling 3-234

T

- T 3-142
- Tangent 3-147
- Tapping 3-180
- TEMP 6-275, 6-295
- Test socket 2-77
- Thread cutting 3-181
- Three-dimensional representation 5-261
- Tool
 - Change 2-56
 - create new 2-105
 - Delete 2-115
 - Disable 2-113
 - Load 2-116
 - Load in magazine 2-58
 - load new 2-57
 - measure 3-221
 - Measure 2-76, 2-78
 - multiple cutting edges 2-106
 - Oversized 2-113
 - Program 3-129
 - programming 3-142
 - Sort 2-118
 - Unload 2-117
- Tool axis 2-60
- Tool length compensation 2-109, 3-129
- Tool life 2-113
- Tool list 2-101
- Tool magazine 2-103
- Tool monitoring 2-113
- Tool name 2-107
- Tool offset 2-108
- Tool offsets 2-101
- Tool radius compensation 2-109, 3-130
- Tool status 2-114
- Tool type 2-102
- Tool wear list 2-103
- Tools 2-101
- Total offset 2-119
- Transition element 3-146
- Translation 3-228
- Traverse at rapid rate 3-131
- Traverse axes 2-55

U

- Unit of measurement 3-134
- Unit selection 1-41
- User confirmation 2-54
- User data 7-318
- User interface 1-30

V

V 3-142

Variables 7-318

Version display 7-320

View

Change 5-261

Update 5-262

W

WCS/MCS 1-47

Work offset 2-119, 2-124

basic 2-119

coordinate transformation 2-119

definition 2-121

Deselect 2-124

Select 2-124

total 2-119

Work offset list 2-122

Work offsets

call 3-227

Workpiece coordinate system 1-47

Workpiece zero

automatic measurement 2-69

manual measurement 2-64

measure 2-64, 3-219

Workstation 1-19

Z

Zoom 5-260

To
 SIEMENS AG
 A&D MC BMS
 P.O. Box 3180
 D-91050 Erlangen, Germany
 Tel.: +49 (0) 180 5050 – 222 [Hotline]
 Fax: +49 (0) 9131 98 – 2176 [Documentation]
 Email: motioncontrol.docu@erlf.siemens.de

From Name	Suggestions Corrections for Publication/Manual: SINUMERIK 840D/840Di/810D ShopMill User Documentation
Company/Department Address:	Operation/Programming Order No.: 6FC5298-6AD10-0BP1 Edition: 11.02
<hr/> Phone: / <hr/> Fax: /	Should you come across any printing errors when reading this publication, please notify us on this sheet. Suggestions for improvement are also welcome.

Suggestions and/or corrections

Overview of SINUMERIK 840D/840Di/810D Documentation (11.2002)

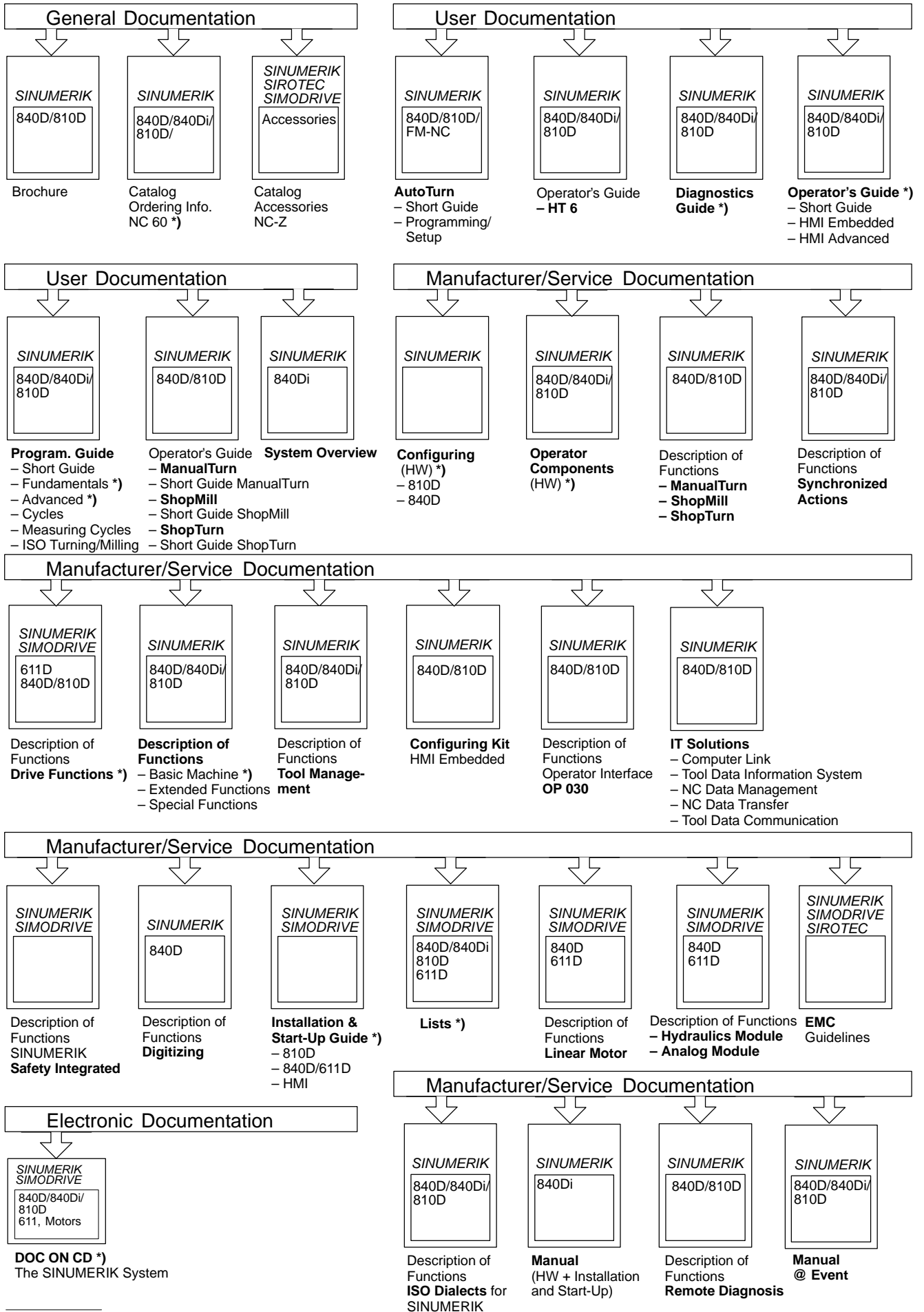

*) These documents are a minimum requirement

Siemens AG

Automation & Drives

Motion Control Systems

P. O. Box 3180, D – 91050 Erlangen
Germany

www.ad.siemens.de

© Siemens AG 2002
Subject to change without prior notice.
Order No. 6FC5298-6AD10-0BP1

Printed in Germany