



Instruction manual

ENG

GT 112-E



LNS America
4621 East Tech Drive
Cincinnati, Ohio 45245

v02.0 October 2017

TABLE OF CONTENTS

1 BASIC NOTIONS	
1.1 STRUCTURES	1-1
1.2 RIGHTS	1-2
1.3 SAFETY INSTRUCTIONS	1-3
2 TECHNICAL DATA	
2.1 CHARACTERISTICS	2-1
2.2 CAPACITY(DIAMETER)	2-1
2.3 BAR DIAMETER MEASUREMENT	2-2
2.4 FLOOR PLAN	2-3
2.5 LAYOUT OF THE ELEMENTS	2-5
3 SETTING INTO OPERATION	
3.1 TRANSPORTATION	3-1
3.2 POSITIONING OF THE BAR FEEDER	3-3
3.3 MOUNTING	3-5
3.4 CONNECTION	3-7
4 ELECTRICS	
4.1 LAYOUT OF THE ELEMENTS	4-1
4.2 ELECTRICAL COMPONENTS	4-2
4.3 SYMBOLS	4-10
4.4 PLC I/O	4-11
4.5 DIAGRAMS	4-12
4.6 INTERFACE	4-16
4.7 SAFETY SWITCHES	4-20
5 PNEUMATICS	
5.1 GENERAL DESCRIPTION	5-1
5.2 F.R.L. AIR FILTERING UNIT	5-2
5.3 SOLENOID VALVE MANIFOLD	5-4
5.4 MAINTENANCE	5-6
5.5 PNEUMATIC DIAGRAMS	5-7
6 HYDRAULICS	
6.1 GENERAL DESCRIPTION	6-1
6.2 LAYOUT OF THE ELEMENTS	6-1
6.3 DESCRIPTION of THE ELEMENTS	6-2
6.4 MAINTENANCE	6-4

7 GENERAL DESCRIPTION	
7.1 SCREW TYPE LOADING SYSTEM	7-1
7.2 GUIDING SYSTEM	7-2
7.3 PUSHER ASSEMBLY	7-6
7.4 ROTATING SLEEVE	7-8
7.5 COLLET	7-9
7.6 DIAMETER CHANGEOVER	7-10
7.7 BELT	7-12
7.8 VISE (self-centering)	7-13
7.9 BAR MEASURING DEVICE	7-14
7.10 HEADSTOCK SYNCHRONIZATION DEVICE	7-15
7.11 LATHE CONNECTING PARTS	7-16
7.12 RETRACTION SYSTEM (OPTION)	7-17
7.13 BAR PREPARATION	7-18
7.14 SPINDLE REDUCTION TUBES	7-19
8 OPERATION	
8.1 REMOTE CONTROL OPERATION	8-1
8.2 POWERING AND EMERGENCY STOP	8-5
8.3 AUTOMATIC/MANUAL SEQUENCE	8-7
8.4 OPERATION PARAMETERS	8-9
8.5 SERVICE PARAMETERS	8-20
9 TROUBLE SHOOTING GUIDE	
9.1 WARNING MESSAGES	9-1
9.2 ERROR MESSAGE MAP	9-4
9.3 ERROR MESSAGE DESCRIPTION AND TROUBLE SHOOTING GUIDE	9-5
9.4 SERVO AMPLIFIER ERROR MESSAGES	9-18
9.5 FACTORS AFFECTING PERFORMANCE	9-33
9.6 MAINTENANCE	9-35
10 APPENDICES	
APPENDIX A: PROGRAMMING EXAMPLE	10-1
APPENDIX B: ORDERING FORM	10-2
APPENDIX C: ADDRESS LNS	10-3
APPENDIX D: PART PRINTS	A-1

1 Basic notions

1.1 STRUCTURE

This manual consists of various chapters, each containing several points, paragraphs, etc. Lists may be contained in paragraphs.

- The page number is indicated in the top right-hand corner of the page.
- The model of the bar feeder is indicated in the bottom right-hand corner of the page.

Each chapter generally contains all information related to the description and settings of the devices and elements represented.

Therefore, if a setting must be made while you are handling the system, please refer to the chapter on the device to be set, for example “see chapter xxx”.

Whenever possible, the part numbers contained in the instruction manual are shown with the indicated element. The customers can order parts with the number accordingly.

Signs below serve as a tool of reading this manual:



This sign recommends the directions very closely avoiding causing an incident that could result in injury, damage to the equipment, or data loss.



This sign indicates that safety measures must be taken to avoid possible electrical shocks or mishaps.



The notes stress interesting points or comments, and provide useful advice for optimal system operation.

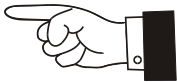

This sign serves to point out the portion mentioned on the description.

1.2 RIGHT

All rights reserved. Reproduction, recording or transmission of all, or any portion, of this manual, in any form or through any means whatsoever, whether mechanical, photographic, sound or other multimedia, without the express written authorization of us is prohibited. We disclaim all responsibility for errors which may be contained in this manual and the problems which may result therefore.

We are not accountable to any improper operation and any damage, debts due to misuse out of compass including unauthorized transportation, handling, installation, repair and design change made by the buyer or a third party. The unit will accordingly not be covered under the warranty.

We cannot take responsibility for any design changes made by clients or a third party. Design changes refer to the modification of equipment, added or deleted items on bar feeder function change, quantity change of bar feeder components, material change, setting method change, and any modification on software designed.

We cannot be held responsible for damage or defect arises from using unauthorized items or products, clients or a third party to set up, add or modify unapproved component.

The names of the products indicated in this manual are registered trademarks.

The manual is conformed to the specification of unit. We keep development and innovation so will make the manual update periodically. Design or specification change is subject to change without prior notice.

The operating life of consumables such as guide channels, rotating sleeves, collets, pushers, inserts and bushings of front rest, and other accessories depends on the working conditions (such as rotating speed and temperature). Therefore these consumables are excluded in the warranty.

Design and specifications are subject to change without prior notice.

1.3 SAFETY INSTRUCTIONS

- Do not handle the equipment without having knowledge of the safety instructions and the instructions for use. Safety instructions for the bar feeder, as well as the CNC lathe, must be strictly observed. We disclaim all responsibility for possible accidents or property damage caused by not following our safety instructions.
- Non-qualified personnel, children, and people under the influence of alcohol or medication should not handle the equipment.
- Loose garments, long hair and jewelry can be dangerous.
- Do not remove any covers while the bar feeder or the machine is under electrical power.
- Do not conduct any maintenance operations during the automatic cycle.
- Do not grasp moving or rotating objects, or nearby elements.
- If certain safety shields or safety covers are removed to conduct maintenance, they must be reinstalled as soon as the maintenance work is completed.
- No servicing should be carried out on the interface or inside the electrical cabinet while the bar feeder or the lathe is under electrical power.
- It is strictly prohibited to jump wire or remove circuit breakers, main switches, and especially safety switches.
- To avoid any harm to people, or damage to components, use only the indicated points for lifting and moving the bar feeder system. No one should be near the handling load, or within the operating range of the overhead hoist/crane, forklift, or any other means used for lifting and transportation. Do not knock the bar feeder while moving it as this could damage it.
- Do not move the bar feeder while it is electrically powered on.
- Please use the bar feeder in a clean environment.
- Please do not use the bar feeder with extreme heat or in a high humidity environment.
- The working area surrounded the bar feeders should always be clear of objects and well lit. The presence of oil on the ground could cause falls; it is important to maintain the floor cleaning on a regular basis.
- Do not place the machine in a damp area and make sure that water or oil does not come into contact with the electrical equipment.
- Do not open the clamping device (collet or chuck) of the lathe manually when the bar feeder is in AUTOMATIC mode (interface).
- Each time the diameter is changed, also adapt spindle reduction tube. The use of spindle reduction tubes is highly recommended for machining bars with diameters smaller than the maximum capacity of the spindle.
- There is no battery inside the PLC. Do not attempt to recharge it.
- For the use and maintenance of the bar feeder, use only parts provided by or recommended by LNS.
- If it is necessary to move the bar feeder after it has been originally installed, do not reinstall it before first contacting our representative.
- The rotating bar stock should never protrude the rear of the lathe spindle.
- We disclaim all responsibility for possible accidents or property damage when safety device is removed.

2 TECHNICAL DATA

2.1 CHARACTERISTICS

Model	2.0M	2.5M	3.2M	12'	4.0M
Channel cover	2 Sections	3 Sections	4 Sections	5 Sections	5 Sections
Bar diameter range	(Ø0.8) Ø1 ~ Ø12.7mm (Ø0.8mm, the specification may vary depending on application.)				
Max. bar length	2060mm	2560mm	3260mm	3736mm	4056mm
Magazine capacity	30pcs / 15pcs				
Overall length	2825mm	3380mm	4080mm	4550mm	4870mm
Overall width	432mm				
Machine weight	333kg	375kg	414kg	433kg	455kg
Hydraulic oil volume	ISO 100 7.4 gallons (28 liters)				
Air pressure	5~7 kgf/cm ²				
Power supply	208-230V 3p (400-480V power supply is available depending on application)				

2.2 CAPACITY (DIAMETER)

Channel size	Pusher size	Recommended bar range
6	5	(0.8)1 ~ 4
8	7	2~7 [without prep up to 5.5]
11	10	4~10 [without prep up to 8]
14	13	4 ~ 12.7 [without prep up to 11]
Unit: mm		

2.2.1 Barstock Straightness Specifications and Performance

For optimum rotational performance speeds, bar stock straightness needs to be .5 mm (.020") per meter (3.25') per side, non-accumulative. Bar stock out of this tolerance will not run at optimum RPM. Other factors such as material type (brass, copper, bronze and other malleable materials), clamping efficiency of the machine workholding, and alignment of the bar feed, oil type, bar preparation and spindle liners will affect optimum RPM capability of the system. GT 112-E is available for loading bar stock diameter from (Ø0.8) Ø1 ~ Ø12.7mm.

However, for optimum machining performance, the gap between bar Stock and the guiding channel should be kept below 4mm. The bigger the gap the more chances of vibrations especially with bent bar stock. Each guiding channel has a range of 10mm above the bar diameter.

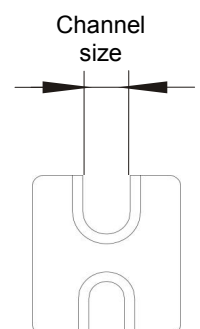

2.3 BAR DIAMETER MEASUREMENT

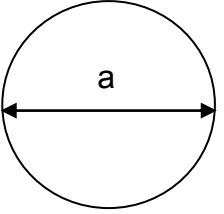
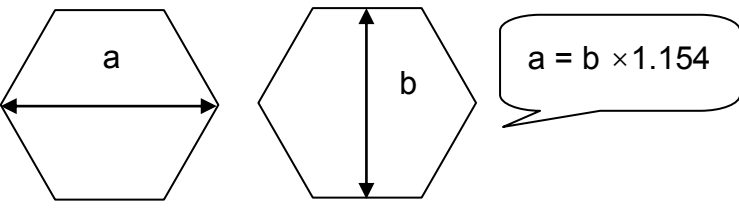
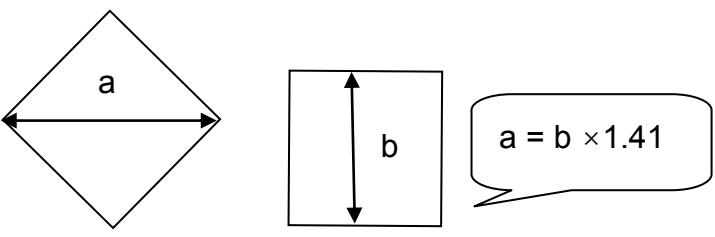
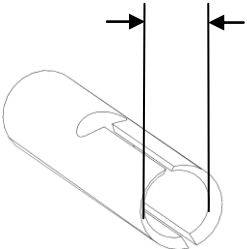
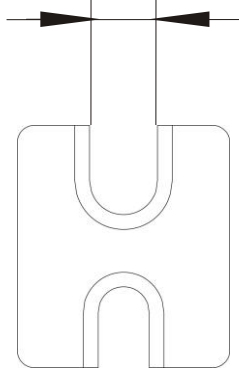
	<p>a = bar diameter b ≠ bar diameter</p>
<p>1</p>	
<p>2</p>	
<p>3</p>	
<p>Pusher collet size = a</p> <div style="display: flex; justify-content: space-around; align-items: center;"> <div style="text-align: center;"> <p>Pusher collet size</p>  </div> <div style="text-align: center;"> <p>Channel size</p>  </div> </div>	

Inch/mm Conversion

To convert to millimeters: multiply inches × 25.4

To convert to inches: multiply millimeters X 0.0394

2.4 FLOOR PLAN

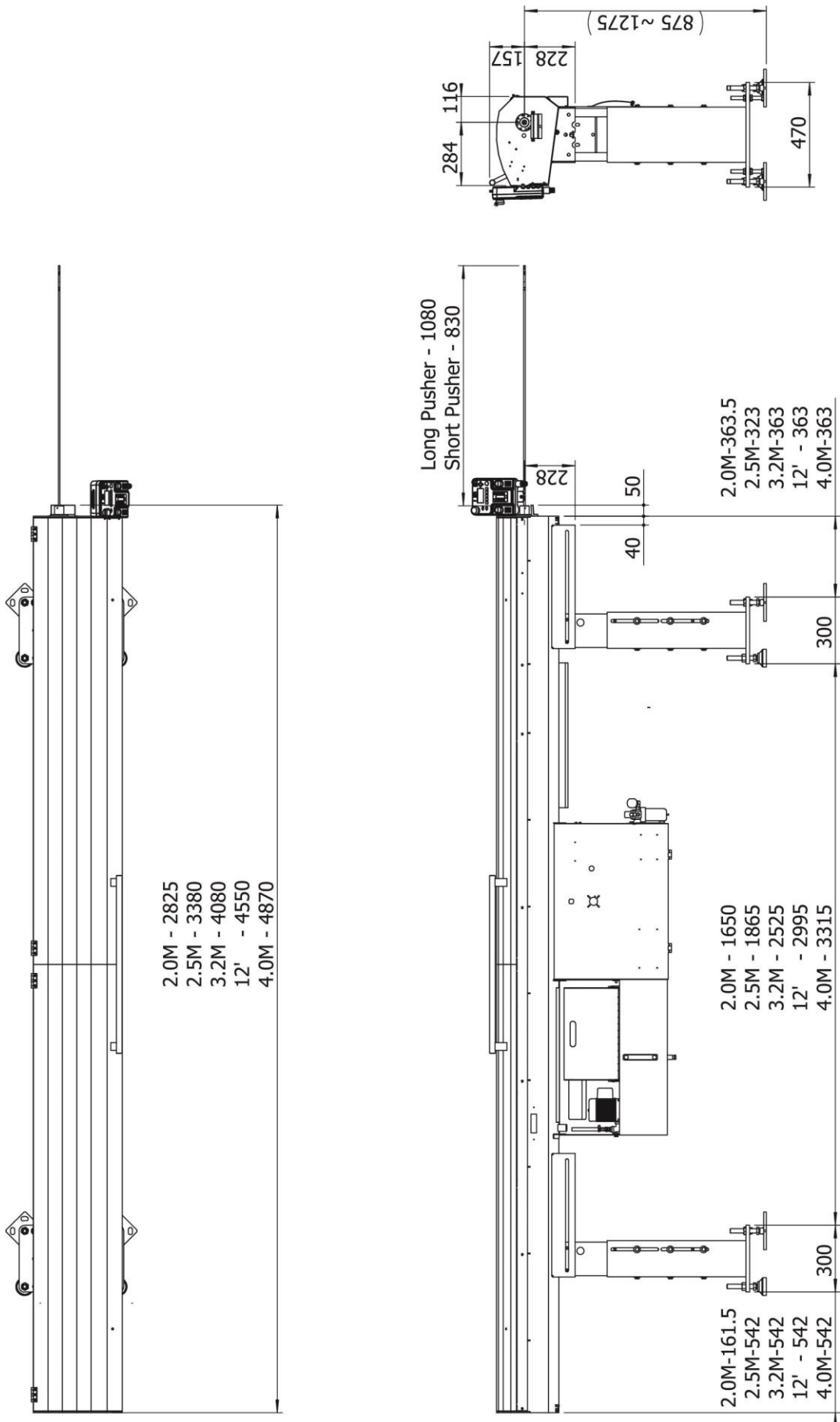

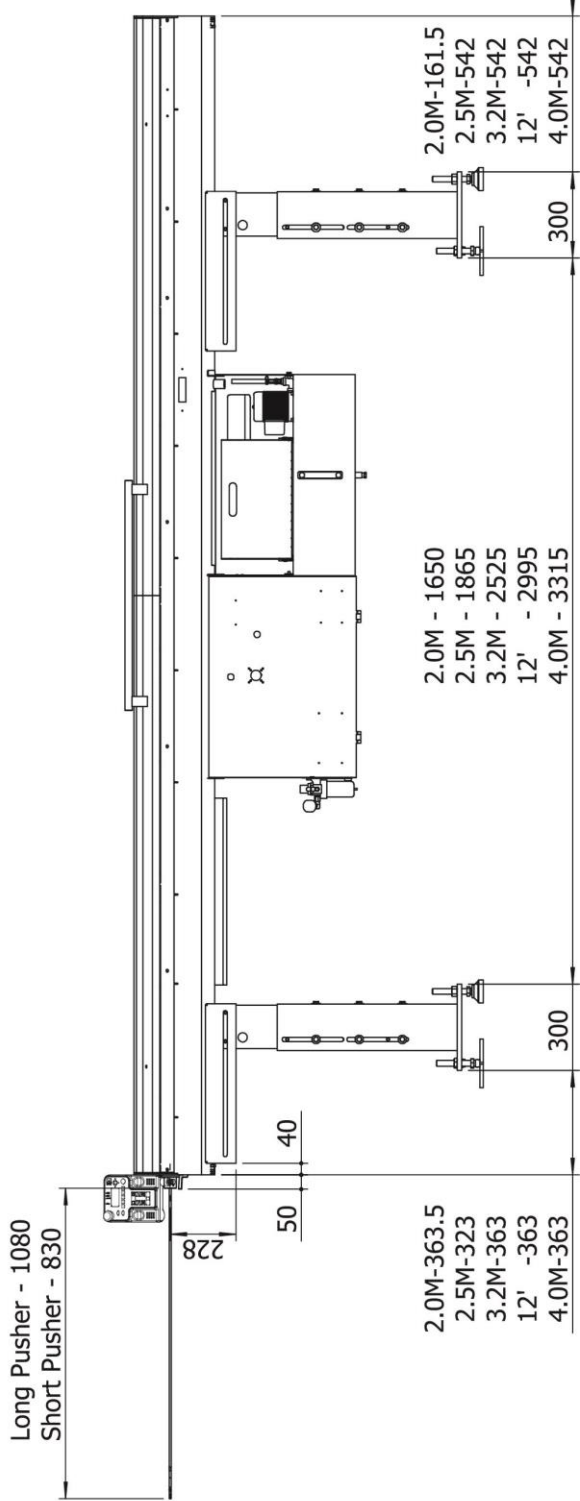
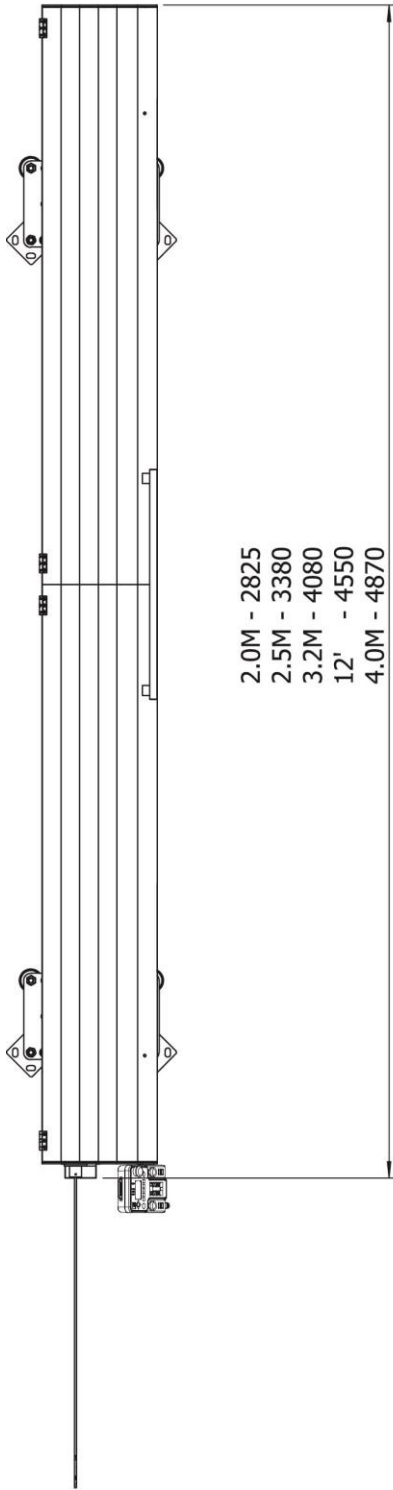

<RtoLF Bar Feeder>

2.5 LAYOUT OF THE ELEMENTS

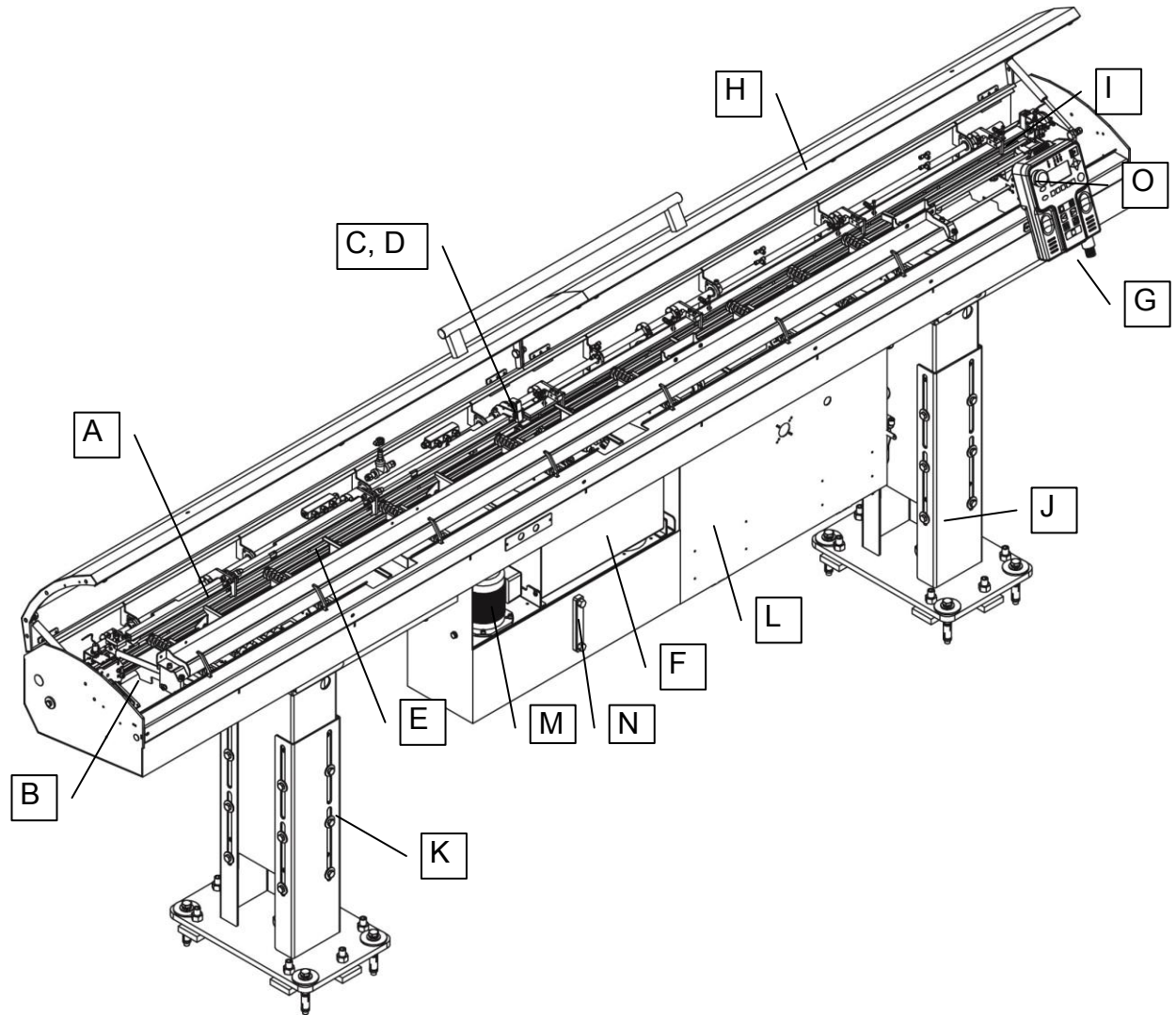

Designation	Description
A	Pusher (not visible)
B	AC Servo motor
C	Vise(Material clamping device)
D	Remnant detecting sensor
E	Guiding channel
F	Remnant box
G	Remote control (HMI)
H	Cover
I	Top cut measurement device
J	Front stand
K	Rear stand
L	Electrical cabinet
M	Hydraulic pump
N	Hydraulic tank
O	Synchronization device

3 SETTING INTO OPERATION

3.1 TRANSPORTATION

The bar feeder may be delivered either on a pallet or packed in a wooden crate according to the customer requirement. The uncrating and lifting instructions recommended below in order to prevent any injuries to persons and damaged to objects.

3.1.1 Unpacking (wooden crate)

For practical and safety reasons, the bar feeder must be unpacked in a spacious, well-lit location.

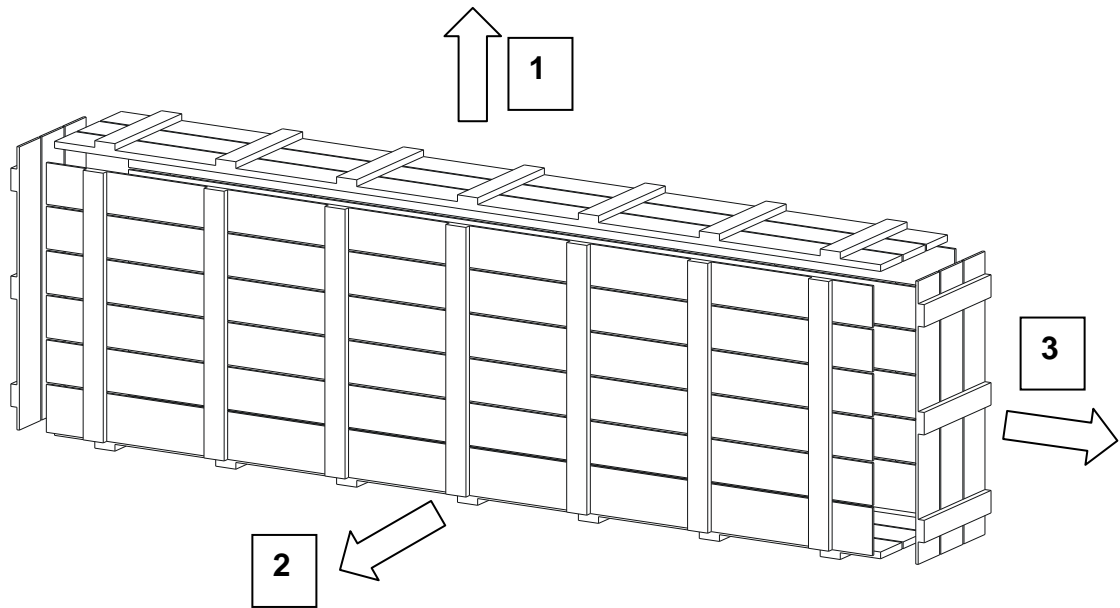

1. If the bar feeder is received in a crate, start by unscrewing the top panel.
2. Remove the front.
3. Remove the side-walls.

A pusher and guiding channel set may be mounted in the bar feeder. Depending on the purchase order, other sets may be delivered in a separate box. The electrical interface diagram is placed inside the electrical cabinet. Documentation, tools, pusher collets, lathe connecting parts, front tube/telescopic tube, and other accessories are packed separately.

3.1.2 Preparing and Hoisting

For installing the bar feeder, it's advisable to contact us or one of our branches offices or one of your local LNS representatives. We cannot be held responsible for any malfunction or any damage to the bar feeder or the lathe due an incorrect installation in which we did not take part in.

< Procedures of preparation >

1. Insert two 25 mm dia. X 1 meter long bars into the holes of the stands, place the hoist vertically above the bar feeder.
2. Place the straps over the ends of the bars, and then attach them to the hoist. The loading capacity of both the hoist and straps must be larger than 1 ton (metric).
3. Raise the hoist to tighten the straps.
4. Remove the screws for holding the bar feeder to the pallet for transportation.
5. Carefully lift the bar feeder and remove the pallet. Ensure that the bar feeder remains balanced.
6. Move the bar feeder towards its final destination behind the lathe making sure that it remains horizontal, in balance and that no one is nearby or under the suspended load. Do not knock the bar feeder against hard objects as you move it as it may damage it.
7. Place the bar feeder behind the lathe, as close as possible and in approximate alignment with the lathe spindle centerline. For the appropriate placement space requirements for the lathe and the bar feeder should be taken into account.
8. Installation of the stand leveling plates:
 - (1) Install leveling screws with bolts in the base plate of the front and rear stands
 - (2) Place the leveling plates (A) under the based plates of the stands so that the leveling screws are in contact with the leveling plates. Preferably have the leveling plates square with the edge of the base plates.
 - (3) Adjust the leveling screws (C) so that the base plates of the stands are at about 30 mm from ground level trying to maintain and even pressure on each leveling screws.
 - (4) Do not tighten the lock nuts (B) until final alignment of the bar feeder.
 - (5) Refer to the next section for proceeding with installation.

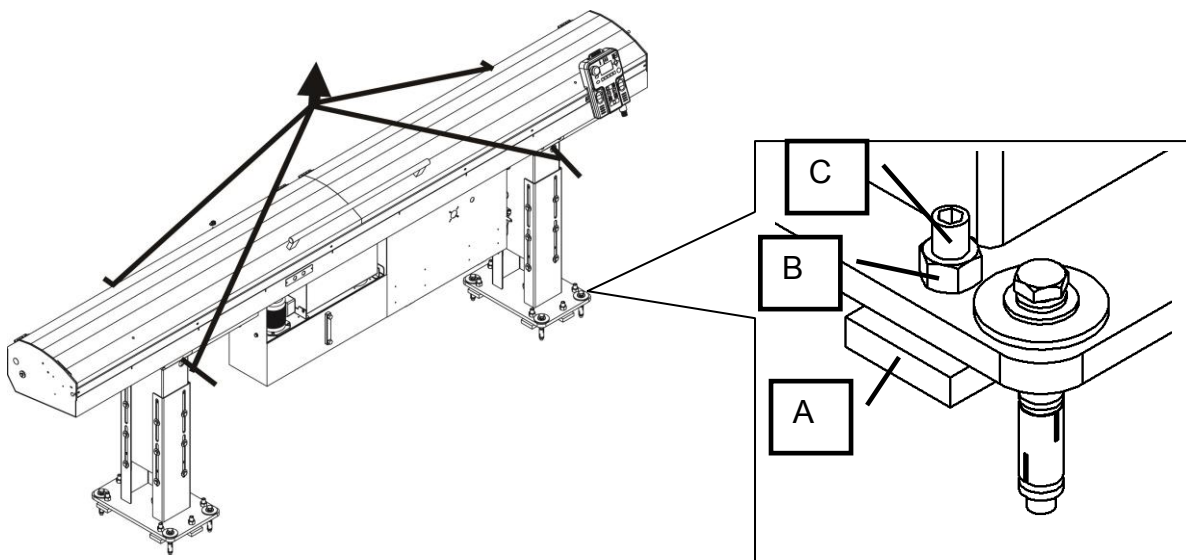

3.2 POSITIONING OF THE BAR FEEDER

3.2.1 Bar stock length check

3.2.1.1 Bar feeder installed behind a Fixed Headstock lathe:

Once the bar feeder is roughly positioned behind the lathe measure the distance (L1) from behind the bar feeder vise jaws to the face of the chuck of the lathe. L1 should not be less than the maximum bar length the bar feeder is capable of loading (refer to Technical Data). Move the bar feeder accordingly until this criteria is met.

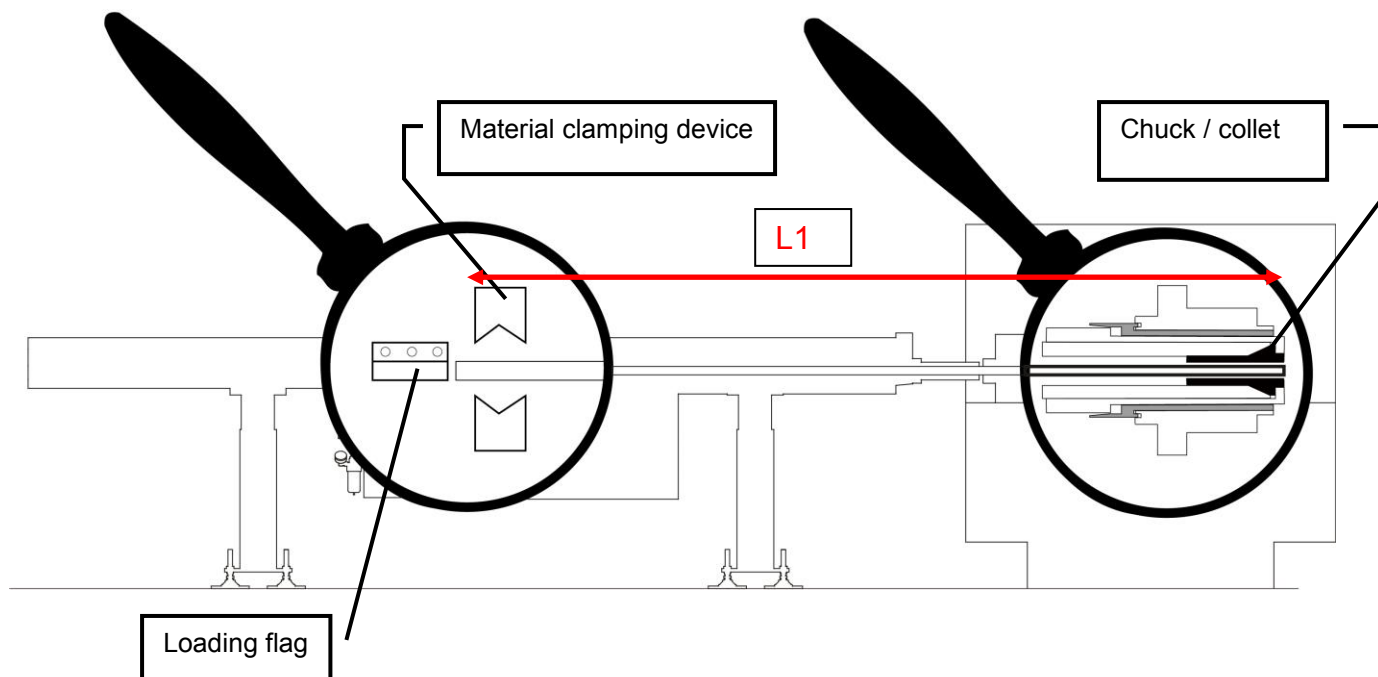

- **Front tube length check**

The front tube (if provided) should be able to cover the space between the bar feeder and the spindle. This will prevent the bar to be exposed.

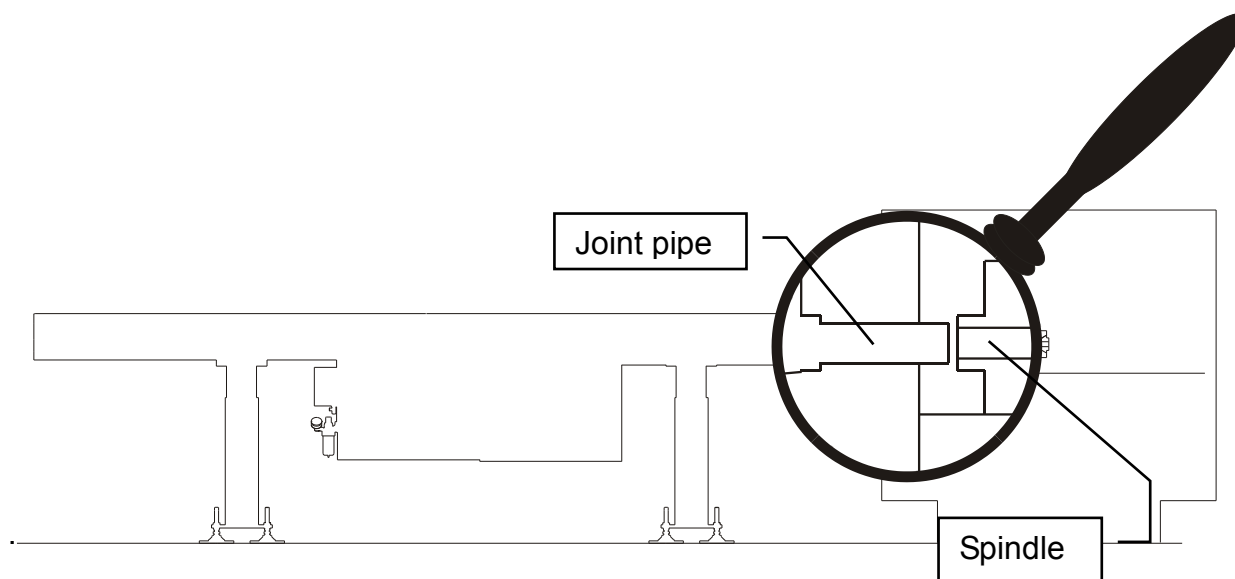

3.2.1.2 Bar feeder installed behind a Sliding Headstock (Swiss type) lathe:

Once the bar feeder is roughly positioned behind the lathe measure the distance (L1) from behind the bar feeder vise jaws and 10 mm behind the guide bushing of the lathe. L1 should not be less than the maximum bar length the bar feeder is capable of loading (refer to Technical Data). Move the bar feeder accordingly until this criteria is met.

Note: Please refer to further instructions related to the Telescopic Tube and safety joint pipe

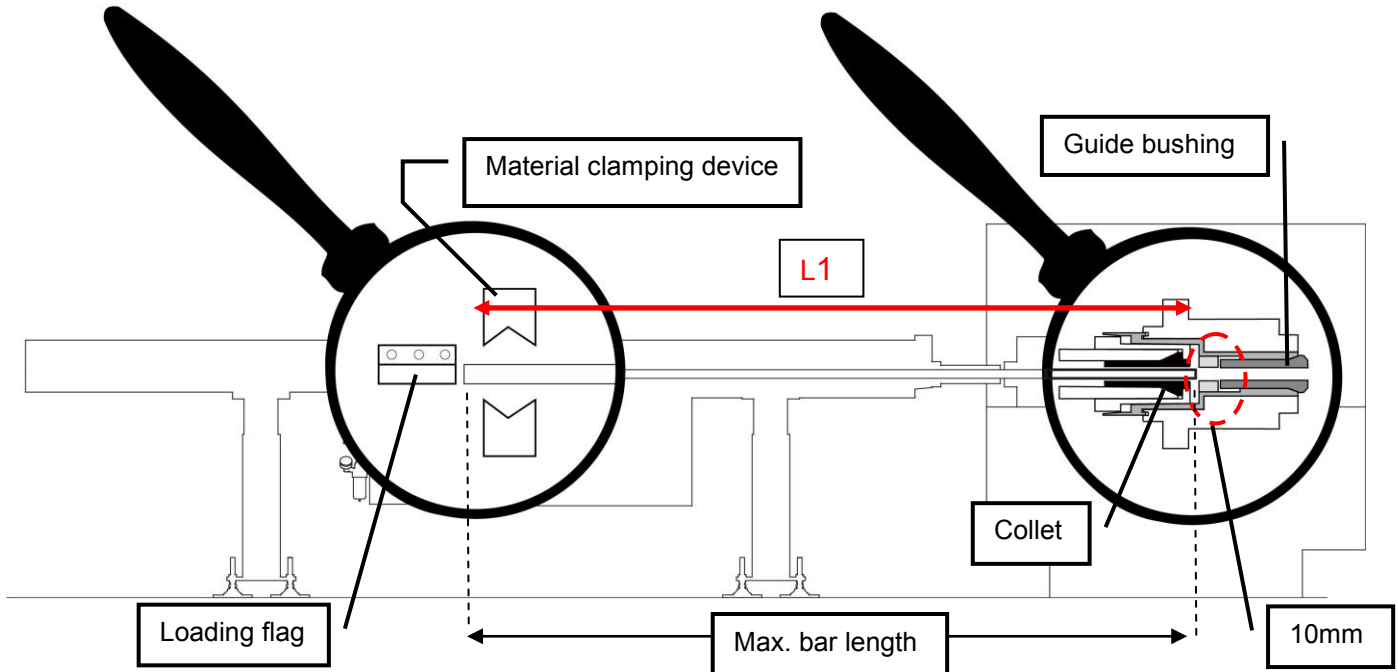

- **Telescopic Tube length check**

Headstock in fully forward position L2 should be no less than 10mm **SHORTER** than the telescopic tube maximum extended length.

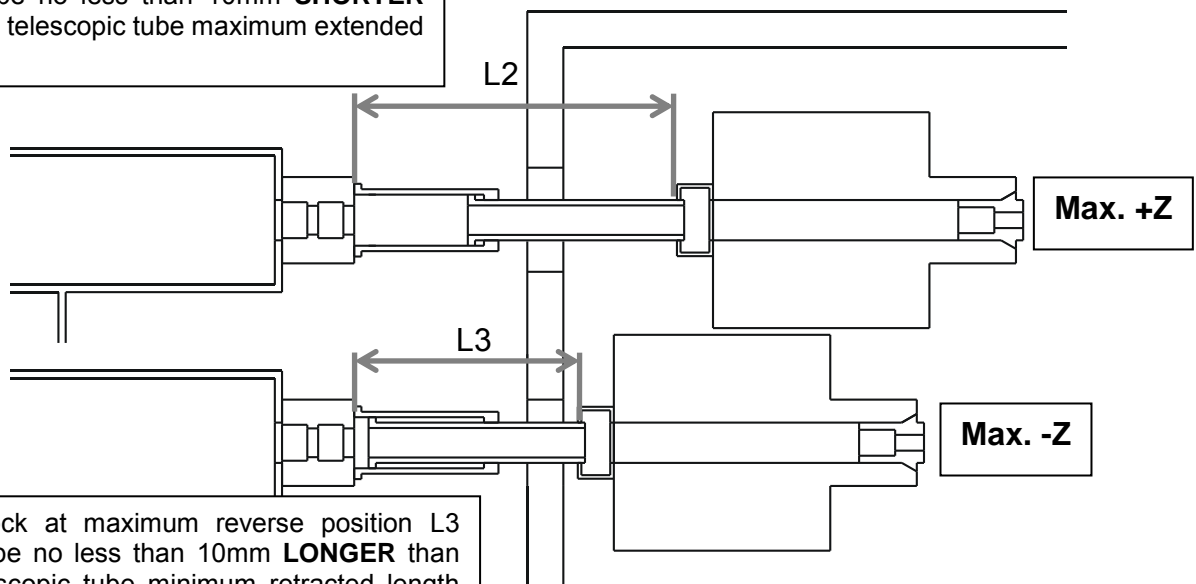

Headstock at maximum reverse position L3 should be no less than 10mm **LONGER** than the telescopic tube minimum retracted length (collapsed).

Note: Depending on the configuration of the machine, the telescopic tube stroke and other mechanical interface components may influence the final position of the bar feeder behind the lathe.

3.3 MOUNTING

3.3.1 Leveling

Attention: Prior to leveling and anchoring the bar feeder the lathe must be leveled

1. Place the leveling pads (A) under each stands.
2. On each leg, loosen the lock nuts (B) of the leveling screws (C). Then, make sure that the weight of the bar feed system is evenly distributed over the 12 support points.
3. Turn the screws (C) until they evenly touch the pads with an equal pressure on each pad.
4. Using a bubble level indicator level the bar feeder using the adjusting the leveling screws (C).
5. Loosen the lock nuts (D) and make sure that the central screws (E) of the front and rear feet are supported. Loosen all locking screws (F).
6. Adjusting the central screws (E), set the height of the bar feed system. Normally, when the reference point is known, this adjustment is approximately set at the factory.
7. Together with the vertical alignment, proceed with the lateral alignment, by shifting the apparatus. Always maintain even pressure from the leveling screws to each leveling pad.
8. When the alignment is satisfactory, tighten all locking screws (F) and nuts (D). Check the alignment and, if necessary, make the fine adjustment with the screws (C).
9. Anchor the bar feeder to the floor using anchoring bolts(G) and according to instructions in the manual (3.3.3.)
10. Prior to securing the bar feeder to the floor it is recommended to check again the bar feeder alignment. The bar feeder alignment is critical for good performance.

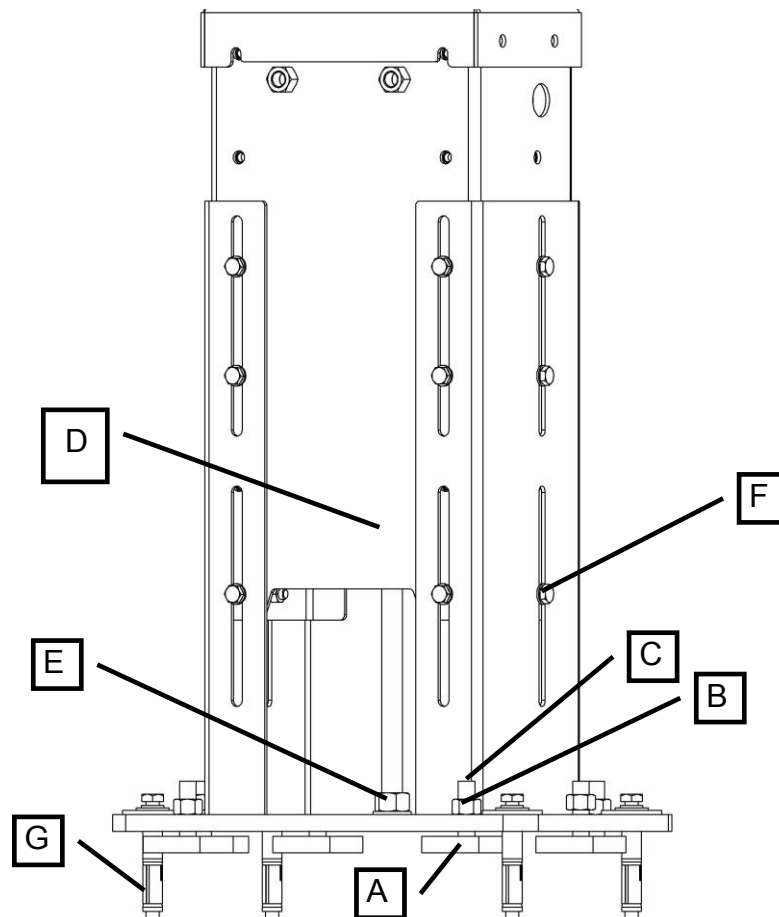

3.3.2 Alignment

Important: Before proceeding with the alignment of the bar feed system, ensure that the lathe is stable and preferably leveled.

The alignment may be carried out using a nylon string, an optical tool or other means. If you do not have any alignment tools, contact LNS or their local representative. They may have alignment tools available or recommend a tool or offer the installation by trained personnel.

For precise alignment, use a 1 or 2 mm diameter nylon string which passes through the back of bar feeder to the lathe chuck. The string must be slightly under tension for precise alignment. The purpose of this operation is to perfectly align the center of the bar feeder with the centerline of the lathe spindle.

1. Clamp an alignment bushing into the chuck of the lathe.
2. Install a bushing at the rear of the bar feeder
3. Pull the string from the rear bushing in the bar feeder through the bushing clamped in the chuck of the lathe.

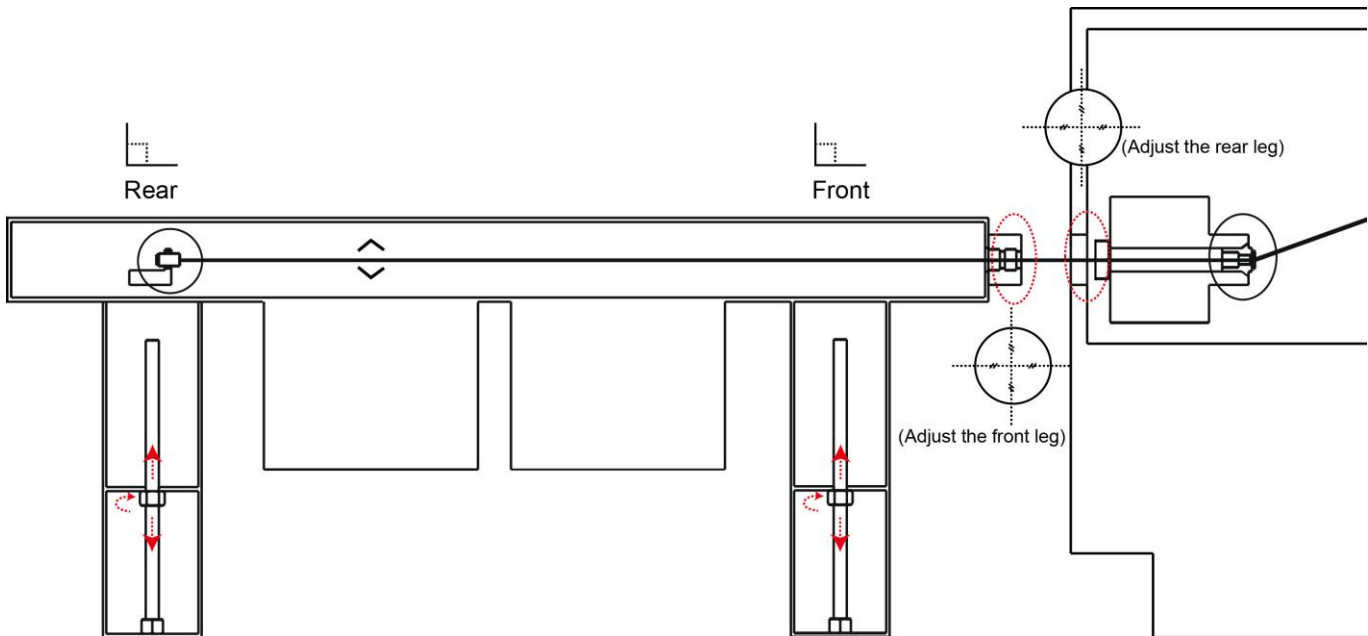

(Please refer to 3.3.2 for bar feeder leveling)

4. Using an alignment tool (LNS or others) proceed to the alignment of the bar feeder so that the nylon string is perfectly centered at the back of the lathe spindle and the front of the bar feeder. Height adjustment are made using the lead screw in each stand,
5. Secure all screws, nuts and other components related to aligning the bar feeder
6. Remove bushings and nylon string

3.3.3 Anchoring to the ground

Once the bar feed system is in place, and perfectly aligned, it should be anchored to the ground to make it stable and secure. To accomplish this, 8 anchorage points are located in the base of the front and rear legs. 8 anchoring bolts (B) must be furnished by the client (Minimum M 10 x 100 mm)(Minimum 1/2" x 4").

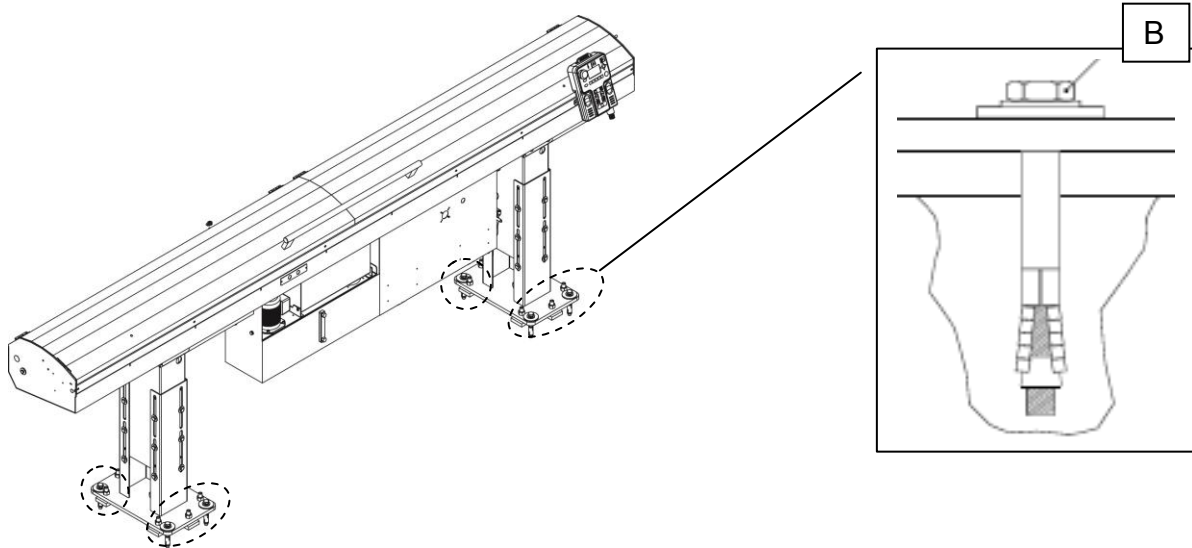

- Once the anchoring bolts are tightened, check the alignment again, and correct it if necessary
- Tighten the nuts of the leveling screws.

3.4 CONNECTION

Once the bar feeder has been aligned and anchored to the ground, the bar feeder must be connected to the interface of the lathe and compressed air need to be connected.

- For the electrical connection, please see Chapter 4, Electrics.
- For the pneumatic connection, please see Chapter 5, Pneumatics.
- For the hydraulic connection, please see Chapter 6, Hydraulics.
- For the mechanical connection, please see Chapter 7, General description.
- For the parameter setting, please see Chapter 8, Operation.

4 ELECTRICS

4.1 LAYOUT OF THE ELEMENTS

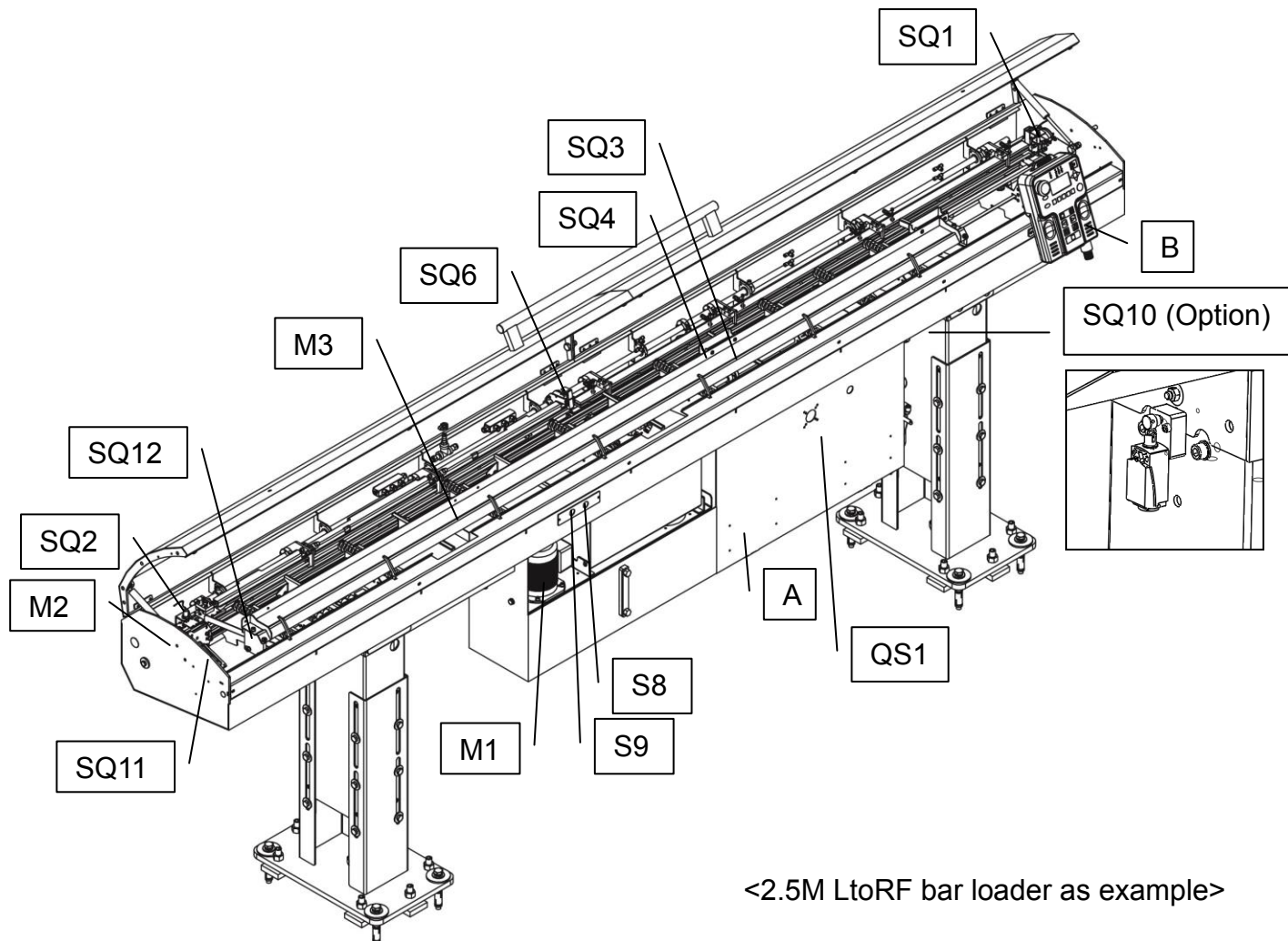

Designation	Input	Part No.	Description
A		XM1.12.A007A.xx	Electrical cabinet
B		XA1.78.A003A	Remote control (HMI)
QS1	--	B55000003	Main disconnect switch
M1	--	XT135050000	Hydraulic pump motor
M2	--	B14120203	Servo motor
M3	--	E04121100	Loading motor
SQ1	X03	B18120500	Bar measuring device
SQ2	X13	B18120400	Home position
SQ3	X14	C11111100	Guiding channel opened
SQ4	X15		Guiding channel closed
SQ6	X17		Vice system
SQ10	X21	4.484	Retraction safety (Option)
SQ11	X20	4.894	Main cover Safety
SQ12	X22	B18120500	Loading Sensor
S8	X26	B18160110	Loading button
S9	X27	B18160110	Unloading button

4.2 ELECTRICAL CABINET

4.2.1 Electrical cabinet

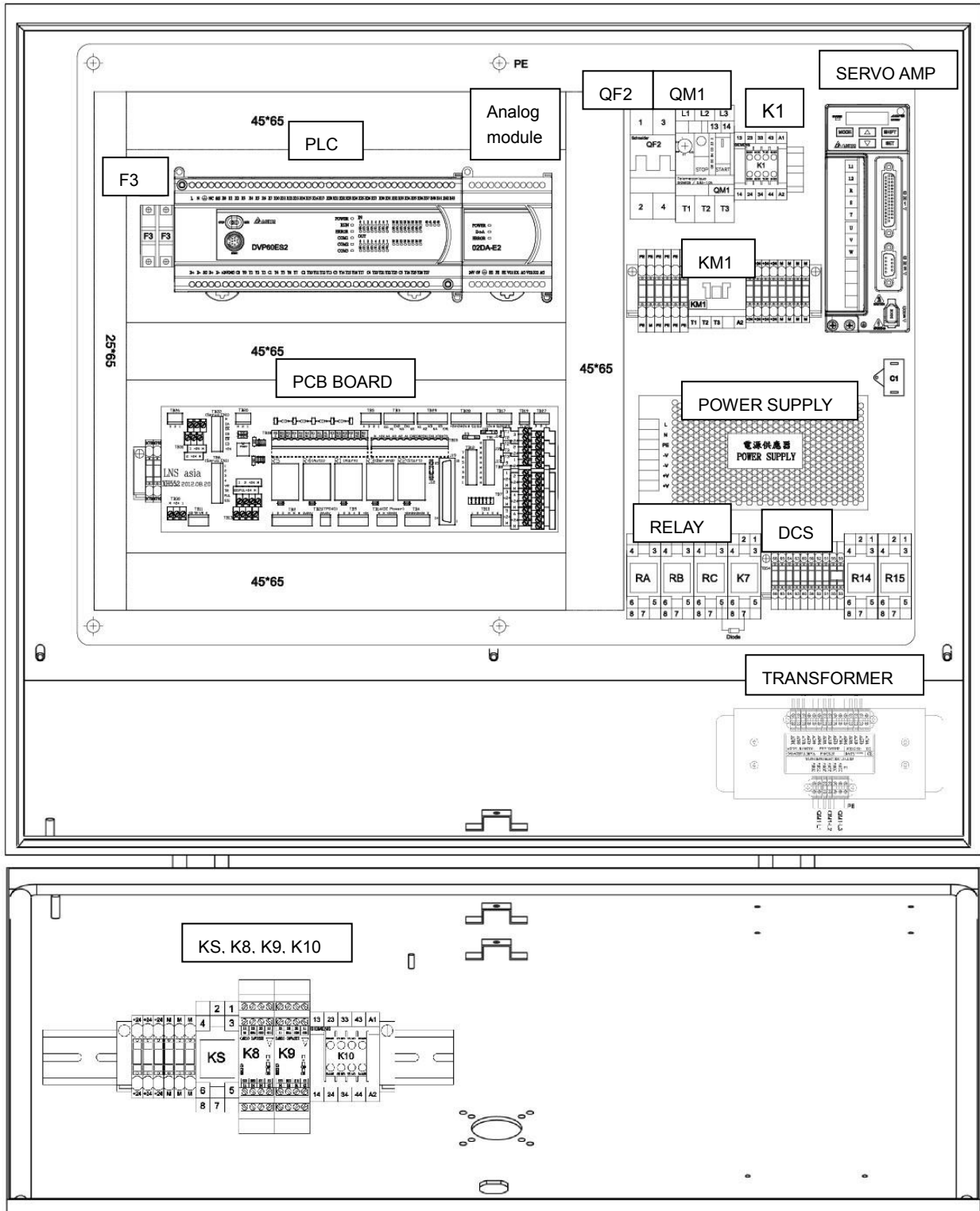

Designation	Part No.	Description	Designation	Part No.	Description
PLC	B12140800	Programmable Logic Controller	SERVO AMP	B14120101	Servo amplifier
Analog module	B12140810	02DA-E2	KM1	B18180001	Hydraulic pump (M1) contactor
PCB BOARD	B23140500	PCB Box	POWER SUPPLY	B25120020	24V DC power supply
	B11203011	PCB Board			
	B24110150	Relay			
QF2	B18210030	24V DC power supply and PLC circuit breaker	RELAY	B24110150	RA, RB, RC,K7
				B11000065	Relay Base
				B22000027	Diode
QM1	B19110510	Hydraulic pump (M2) circuit breaker	KS	B24110150	CE Relay
				B11000065	
			K8	B24110200	CE Relay (DCS version)
			K9	B24110200	
K10	4.932				
K1	4.932	Electromagnetic contactor	Transformer	B55000051	Multi voltage transformer
F3	B11000027	Fuse	DCS	B23160003	Dual Channel Safety(Optional)
	B66000011	Fuse Holder			
RELAY (for 2 position retraction)	B66000007	Relay R14,R15			
	B11000065	Relay Base			
	B13204037	Cable			

4.2.2 Servo drive power loop components

The servo drive is powered by 3 phases 220V AC through K1 contactor.

a) K1 electromagnetic contactor

K1 is energized by the emergency stop loop. When the emergency stop loop is open, the contactor K1 will be de-energized and interrupt the power supply to the servo drive.

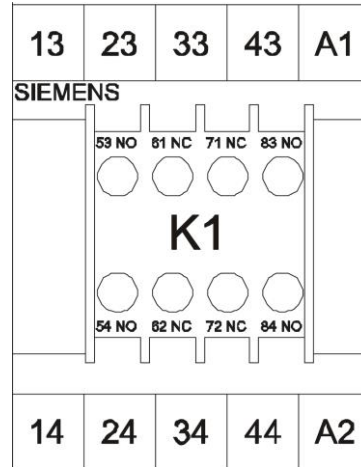

b) Servo amplifier

The Servo Amplifier controls the movement of the Servo Motor.

<Note> Never change the parameter settings of the servo amplifier. They are factory pre-set. Please contact the factory if help is required.

Designation	Description
A	I/O connector
B	Encoder connector
C	Serial connector
D	Control circuit terminal (L1, L2) Used to connect to 100-230 VAC power supply
E	Main circuit terminal (R, S, T) Used to connect 200-230 VAC power supply
F	Heatsink Used to secure servo drive and for heat dissipation
G	Protective earth
H	Display

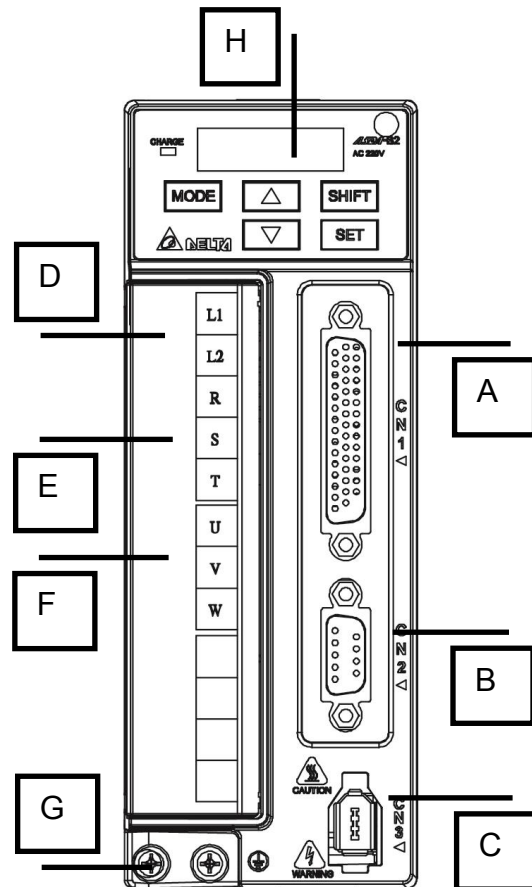

4.2.3 Hydraulic pump power loop components

The hydraulic pump M1 is powered by 3 phase 220V AC through KM1 contactor and protected by QM1 circuit breaker.

a) Circuit breaker - QM1

QM1 interrupts the 3 phase power to the hydraulic pump motor. It is also connected in the emergency stop circuitry. If the motor overloads (the breaking current is set to 2.5 amperes) the circuit breaker trips from ON to OFF. Both power supply to hydraulic pump and the emergency stop loop are interrupted. After the problem is fixed, reset the circuit breaker by switching to ON.

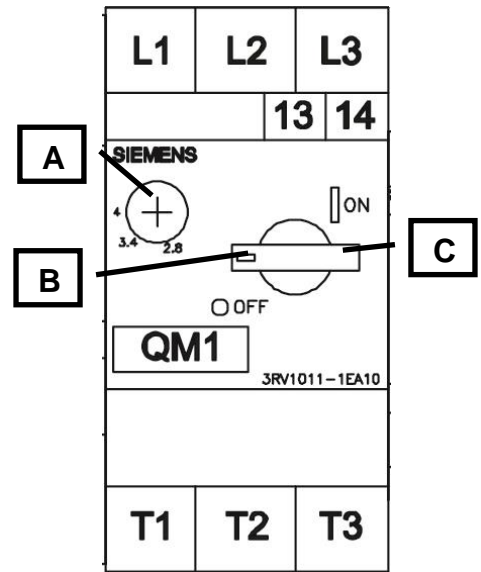

Designation	Description
A	Rating adjustment (preset at 2.5A)
B	Switch button
C	

b) KM1

The KM1 contactor is energized by 24V DC from PLC output Y03. When this signal is OFF, the KM1 is de-energized and the power to hydraulic pump is cut off.

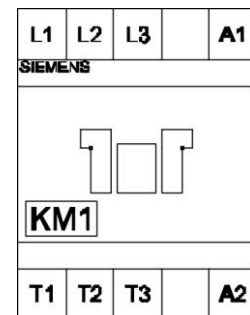

4.2.4 PLC and 24V DC supply power loop component

Breaker QF2 protects the two phase which powers both PLC and 24V DC power supply. If the power exceeds 4A, the breaker trips and lever B flips down. The power supply to the PLC and 24V DC power supply is immediately interrupted.

After the problem is fixed, reset the breaker by flipping lever B up.

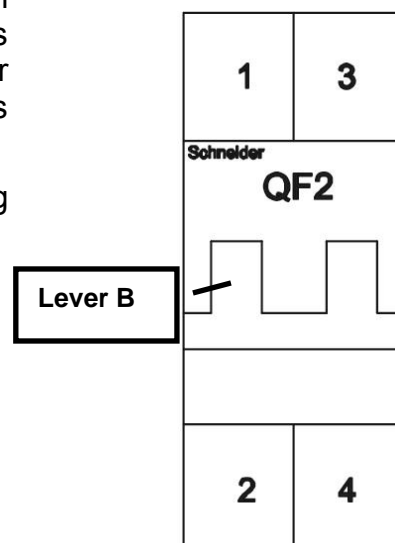

4.2.5 PLC (Programmable Logic Controller)

a) Primary module

The PLC processes the signals from the interface, sensors and remote control and sets the outputs according to the program logic. In addition, the PLC also provides 24V DC power to HMI.

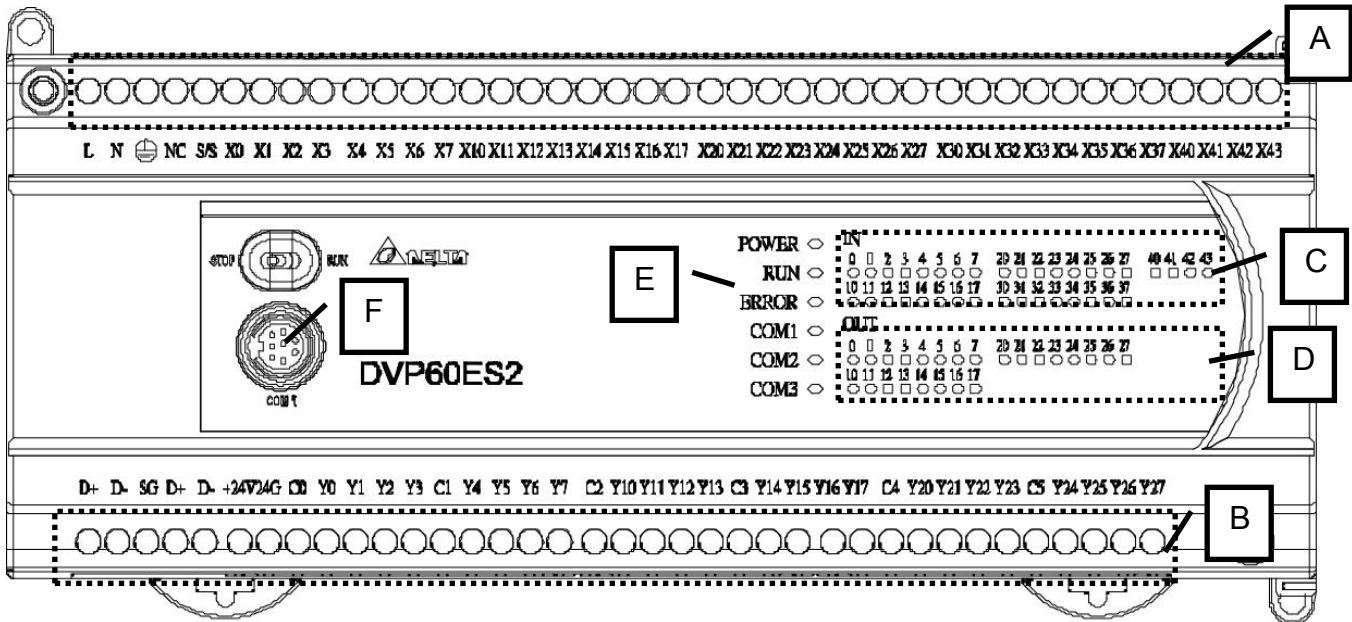

4.2.6

Designation	Description
A	Input terminals.
B	Output terminals.
C	Input signals indication LED. Indicate the status of inputs X0 to X43.
D	Output signals indication LED. Indicate the status of outputs Y0 to Y27.
E	PLC status indication LED.
F	Communication port.

b) Analog module

The analog signals serves to control the torque and speed of the servo motor.

Designation	Description
A	Torque control output contacts
B	Speed control output contacts
C	Power indication LED

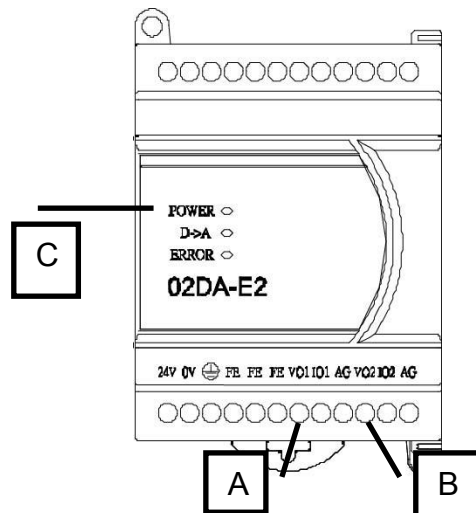

4.2.6 24V DC power supply

The power supply converts AC 220 V to 24V DC for the low voltage circuit.

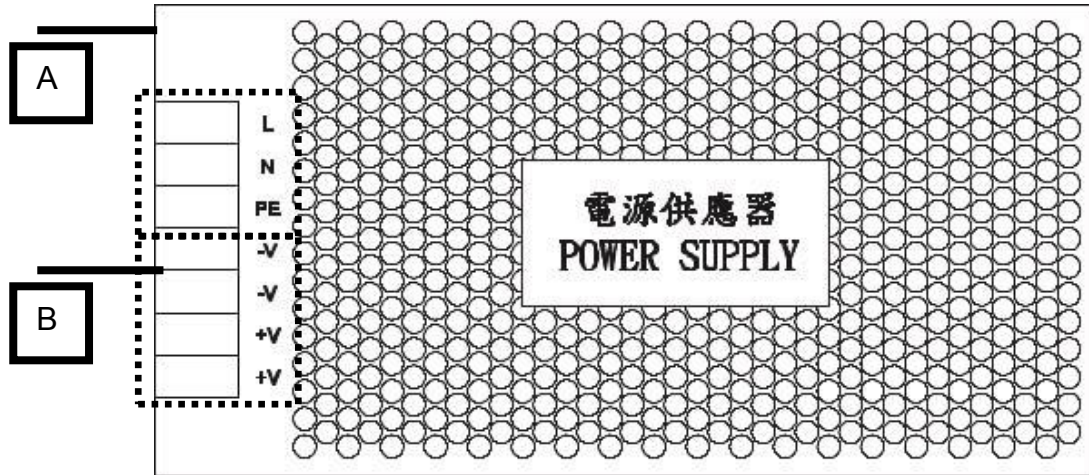

Designation	Description
A	220V AC input terminals
B	24V DC output terminals

4.2.7 PCB (Printed Circuit Board)

PCB is a board with circuit printed and electrical components welded on the surface. It offers sockets and terminals for electrical components like relays, cables and fuses.

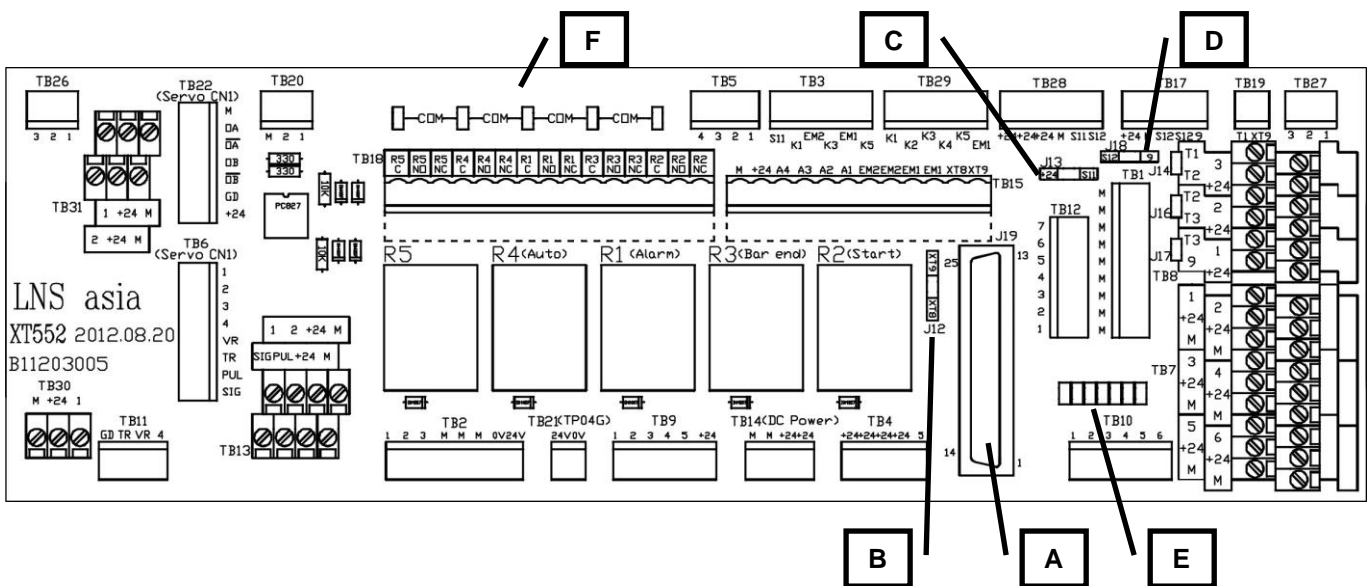

Terminal block designation	Contacts	Description
A	--	Remote control terminal
B	--	XT8, XT9 bridging terminal
C	--	S11, +24 bridging terminal
D	--	S12, 9 bridging terminal
E	--	Jumpers rest terminal
F		24V DC common contacts bridging terminal
R1	--	Alarm relay
R2	--	Start signal relay
R3	--	BAR END relay
R4	--	Bar feeder AUTO relay
R5	--	INCHING relay
TB1	9 sets M contact	Common joints terminal for Y04-Y06, Y10, Y13, Y14
TB2	1, 2, 3, M, M, M, 0V, 24V	Servo control signals.
TB3	S11, EM1, EM2, K1, K3, K5	Terminals of emergency stop buttons
TB4	4 sets +24V contact, 5	+24 common joints of C1-C4
TB5	1, 2, 3, 4	Signals from interface terminals A1, A2, A3, A4.
TB6	1, 2, 3, 4, VR, TR, PUL, SIG	Signal terminals of servo amplifier CN1 connector.
TB7	1, +24, M, 2, +24, M, 3, +24, M, 4, +24, M, 5, +24, M, 6, +24, M	Signal terminals of SQ3, SQ4, SQ6, SQ2, SP1, SQ1
TB8	2, +24, 3, +24	Signal terminals of SQ11, SQ10 T1, T2, T2, T3, T3, 9 bridging terminal
TB9	1, 2, 3, 4, 5, +24	PLC signals for energizing R1, R2, R3, R4, R5.
TB10	1, 2, 3, 4, 5, 6	Connect to PLC input contacts X14, X15, X17, X13, X12.
TB11	GD, TR, VR, 4	- GD, TR, VR signals from PLC - Connect to PLC input contacts X02
TB12	1, 2, 3, 4, 5, 6, 7	Signal terminals of remote control station button S1, S4, S6, S7, S5, S2 and S3
TB13	SIG, PUL, +24, M, 1, 2, +24, M	Synchronization device terminals.
TB14	M, M, +24, +24	DC power supply terminals.
TB15	M, +24, A4, A3, A2, A1, EM2, EM2, EM1, EM1, XT8, XT9	Interface signals input terminals
TB17	+24, M, S12, S12, 9	Connect to QM1 and K1
TB18	C, NO, NC for R5, R4, R1, R3, R2	Interface signal output terminals.
TB19	T1, XT9	Short circuit
TB20	M, 2, 1	Encoder signal terminals.
TB21	24V, 0V	Power supply for HMI
TB22	0A, /0A, 0B, /0B, GD, +24	Servo CN1 control signal terminals.
TB26	3, 2, 1	Connect to PLC input contacts X11
TB27	3, 2	Connect to PLC input contacts X20, X21
TB28	+24, +24, +24, M, S11, S12	Connect to K8 safety relay
TB29	K1, K2, K3, K4, K5, EM1	Short circuit
TB30	M, +24, 1	Connect to SP1 air pressure switch

4.2.8 Multi-voltage Transformer (Option)

If the power supplied to the bar feeder does not meet the required 220V AC, the optional multi-voltage transformer must be installed and wired according to the power voltage.

The incoming power must be connected to the primary terminal block. Use the contacts corresponding to the supplied power (346V AC to 440V AC, see drawing below).

The outgoing power is always connected to the 220V AC terminals of the secondary terminal Block.

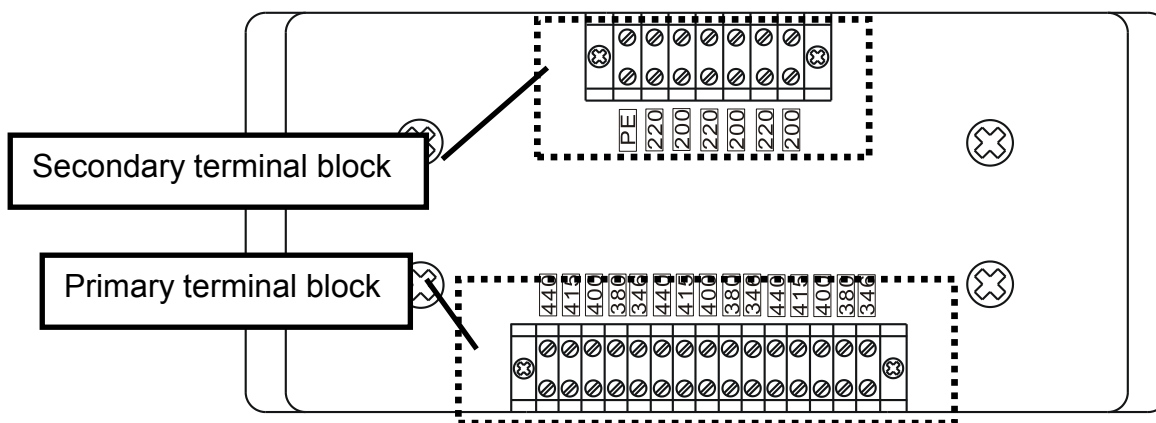

4.3 SYMBOLS

Index	Symbol	Description	Designation
1		Main circuit breaker	QM1
2		Circuit breaker	QF2
3		Diode	--
4		Main power switch	QS1
5		Emergency stop button	STP1, STP2
7		Hydraulic pump	M1
8		Light Emitting Diode	--
9		Electromagnetic switch	KM1 / K1
10		Pressure switch	SP1, SP2
11		Proximity switch	SQ1, SQ2, SQ3 SQ4, SQ6
12		Relay	KS, K7, R1 ~ R5
13		Remote control buttons	S1 ~ S7
14		Servo motor	M2
15		Solenoid valve	YV1, YV2A, YV2B, YV7, YV3, YV8, YV9, YV11

4.4 PLC I/O

DCS : Dual Channel Safety

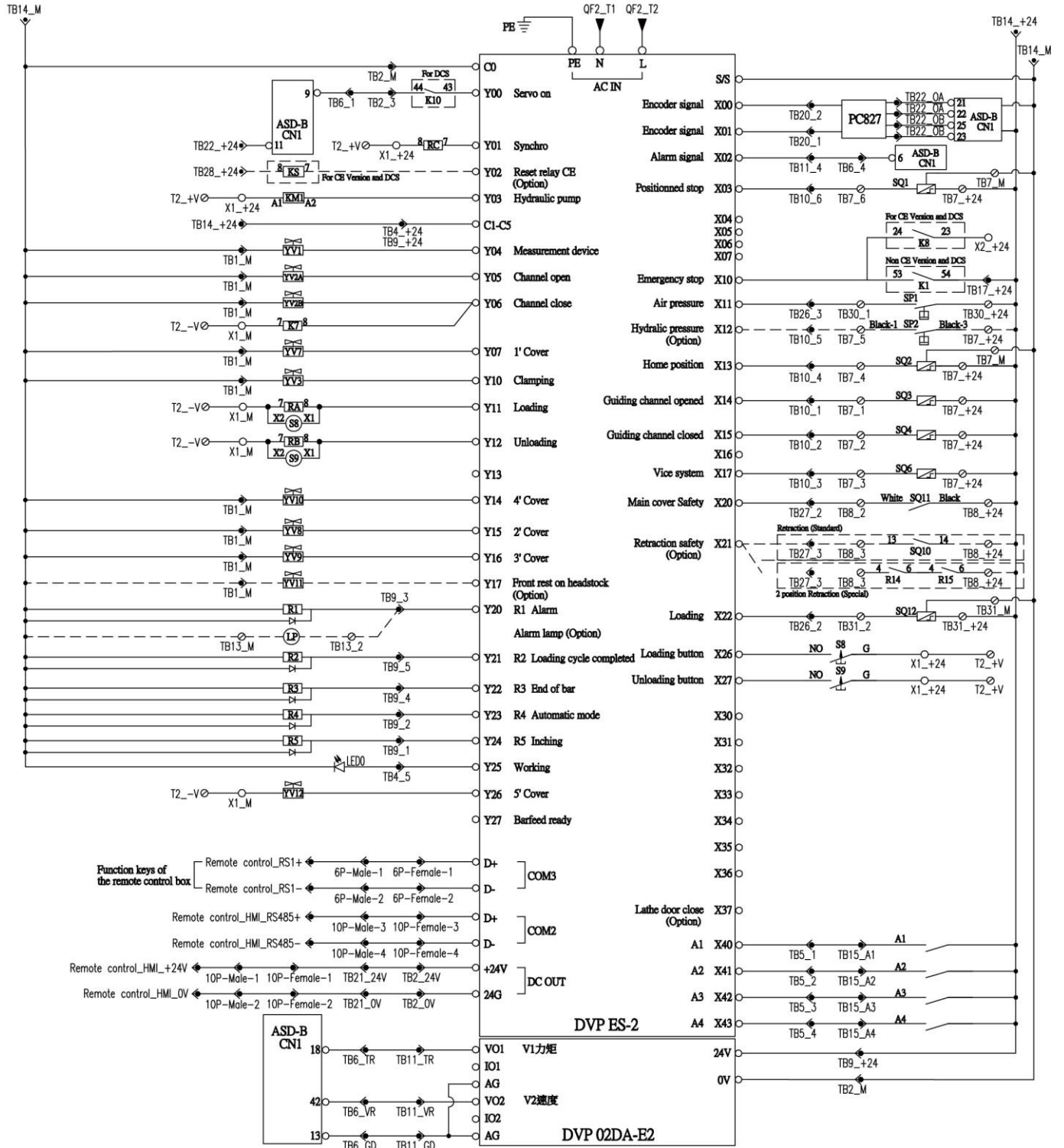

Circuit diagram: XM1.25.A001G

4.5 DIAGRAMS

4.5.1 AC circuit

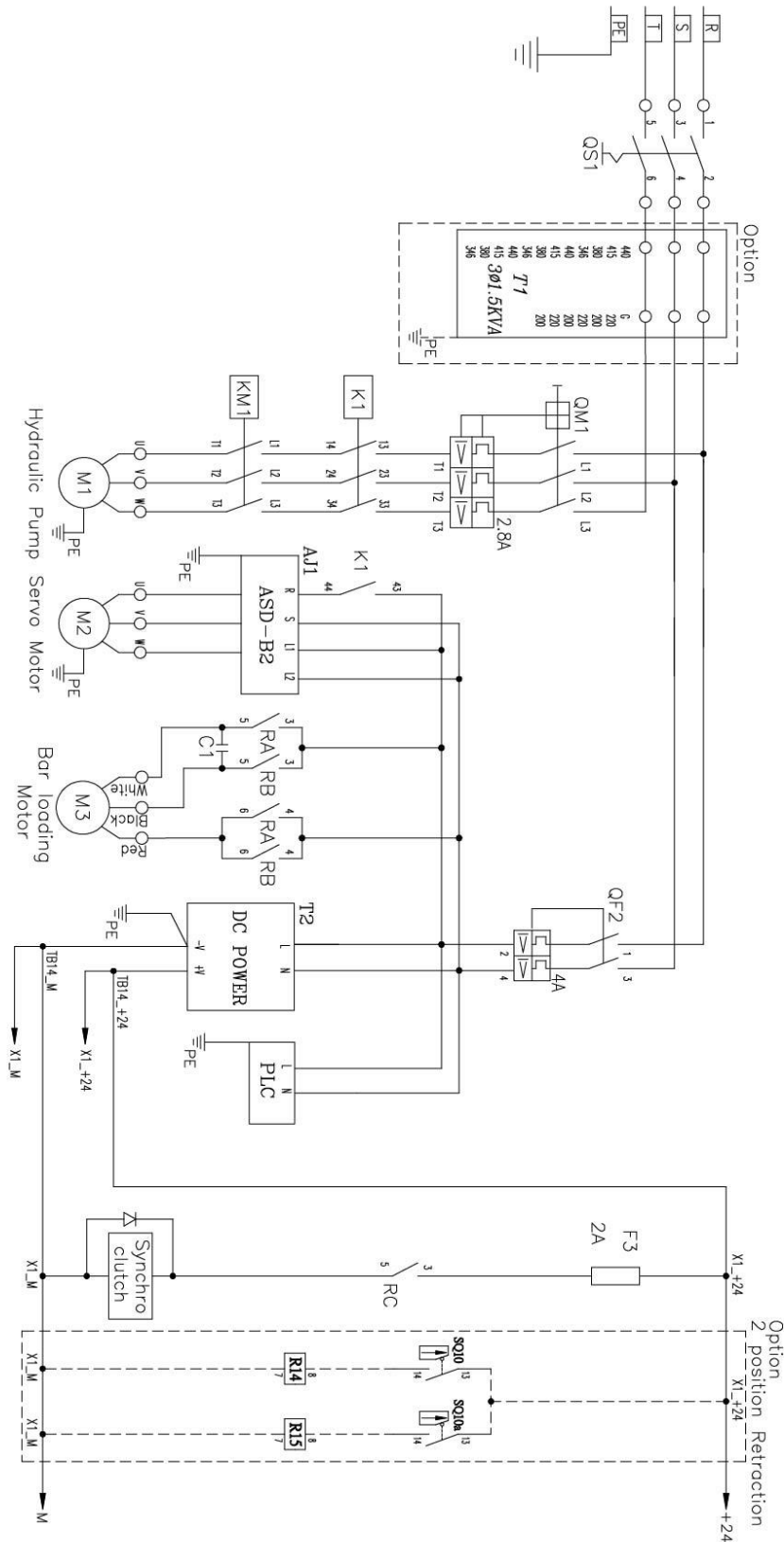

Circuit diagram: XM1.25.A001G

4.5.2 Emergency stop circuit

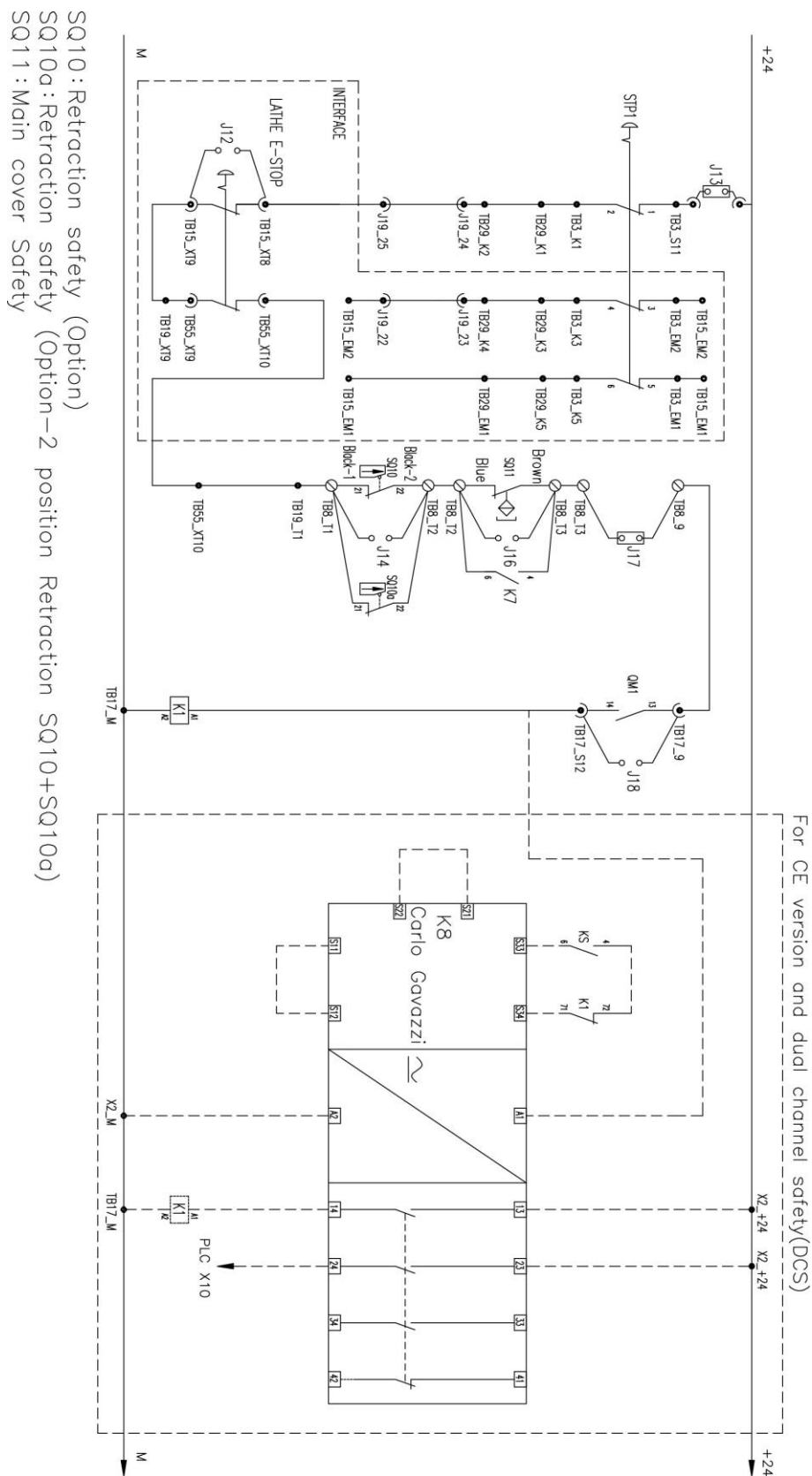

Circuit diagram: XM1.25.A001G

Interface

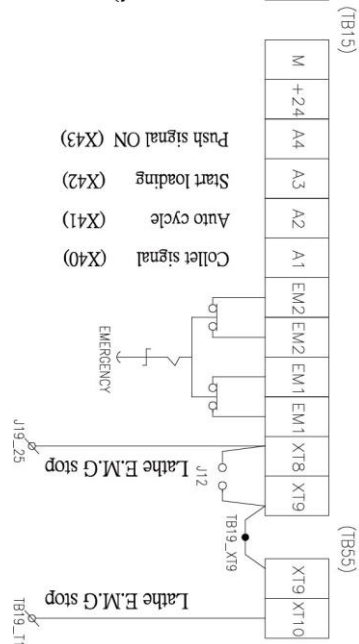
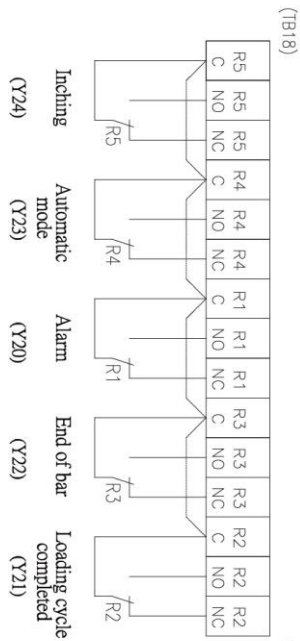

(Option)
dual channel safety(DCS) only

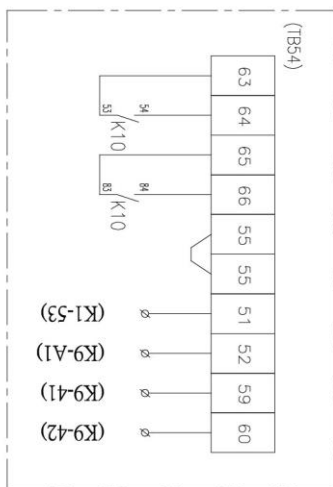

Circuit diagram: XM1.25.A001G

4.6 INTERFACE

Interface presents all the signals exchanged between the bar feeder and the lathe. The interface cables which serve to transmit the interface signals is/are provided by us.

There is a wide range of different interfaces available to meet the requirement of each lathe. The A diagram of the installed interface can be found in the electrical cabinet. Before connecting the bar feeder, make sure the installed interface is suitable for your lathe. If you have any question, please contact our technician for further information.

<NOTE> A correct connection between lathe and bar feeder is critical for safe and reliable operation. It is recommended to request a trained technician to install the bar feeder.

4.6.1 Universal interface diagram

The interface shown in the next page is called UNIVERSAL or STANDARD interface diagram. If the lathe model/type is not specified, this interface will be given with the bar feeder. The universal interface consist most signals which might be transmitted between the lathe and bar feeder. The later the user can change the wiring according to the lathe requirement or contact us for technical advisement.

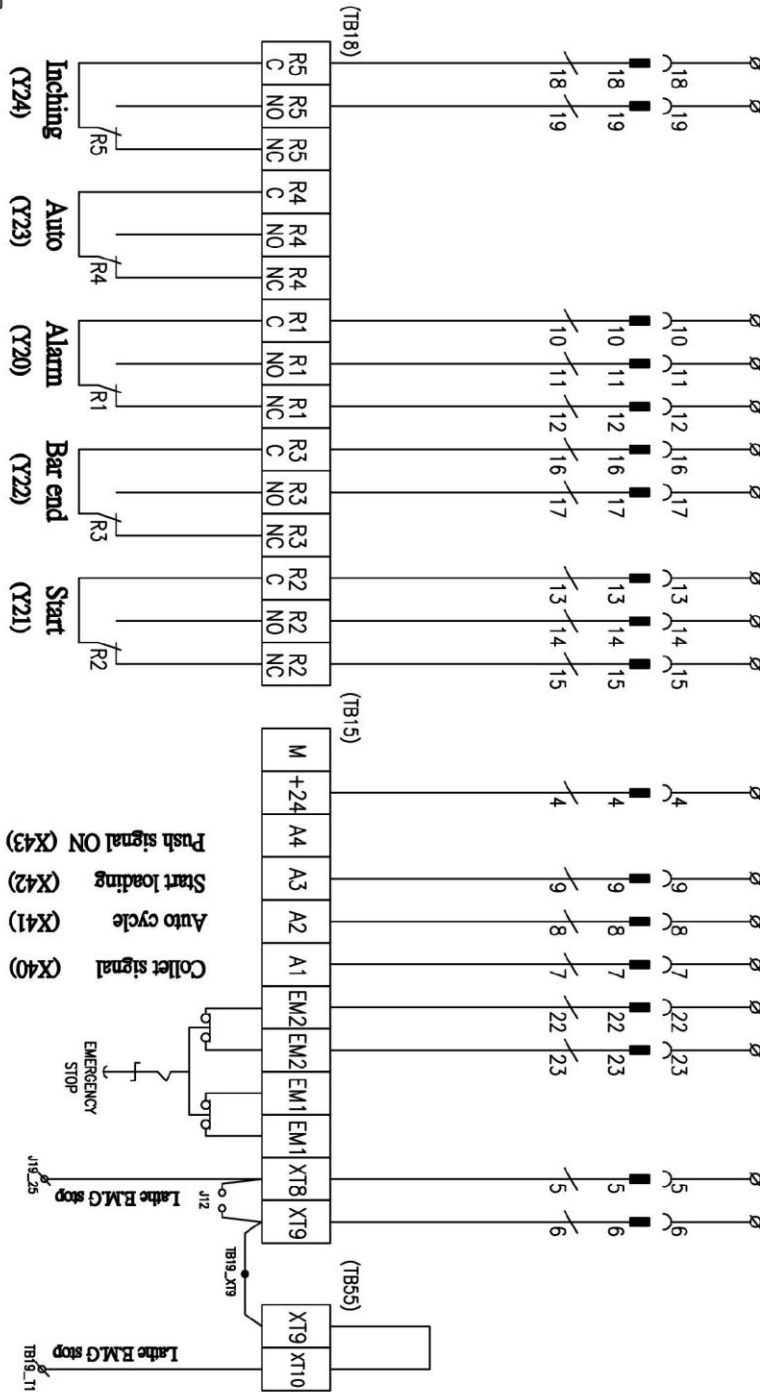
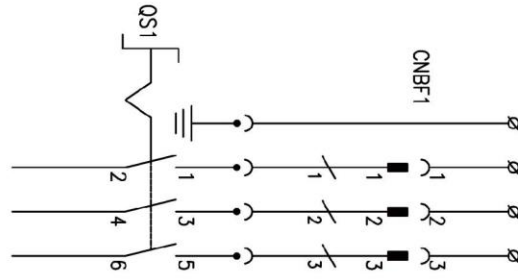

Interface Parameter:

MODE	MODE	MODE	MODE
P00 2	P12 1	P22 1	P46 1
P02 1	P13 1	P24 2	P47 -
P03 1	P14 1	P30 1	P48 -
P04 2	P15 2	P31 1	P49 -
P05 1	P16 1	P32 2	P50 -
P06 1	P17 1	P33 1	P51 -
P07 1	P18 1	P34 -	P52 -
P09 1	P19 2	P43 2	P53 -
P10 1	P20 1	P44 1	P54 -
P11 1	P21 1	P45 1	P74 0
			P75 0

P107 : 1 走刀 Fix type
2 走心, Swiss type

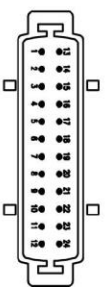

Interface diagram: BXA00001

4.6.2 Signals from the lathe to the bar feeder

The interface logic can be configured with service parameters. Only trained personnel should change these settings.

a) 24V DC power supply

All the signals from the lathe were powered by the 24V DC from the bar feeder. When the corresponding relay energized at the lathe, 24V DC travels through corresponding contact and return to PLC. The PLC hence receives lathe signals.

b) Emergency stop signals from the lathe

This contacts XT8 and XT9 are parts of the emergency stop loop of the bar feeder. When the emergency circuit is open between XT8 and XT9, the bar feeder goes to EMERGENCY STOP MODE and arise an e01 alarm and energize relay R1.

c) Lathe collet signal A1 (PLC input X40)

Collet signal is for confirming the status of lathe chuck (collet). This signal starts feeding and bar change process of bar feeder by itself or combination with other signals.

The signal logic will be handled according to PI00 setup.

d) Auto cycle signal A2 (PLC input X41)

This signal indicates that lathe is in automatic mode and lathe is executing the machining program cyclically. This signal is used for lathe to control pushing forward actions of bar feeders. Pushing forward actions includes First feed, feed into the lathe, feed when lathe chuck is open and lathe chuck is close in synchronization mode.

The signal logic will be handled according to PI10 setup.

e) Start loading signal A3 (PLC input X42)

This signal is used for lathe to decide the timing of pusher to return for changing a new bar stock after Bar end signal is sent from the bar feeder.

The signal logic will be handled according to PI04 setup.

f) Push signal A4 (PLC input X43)

Push signal is used for lathe to control pushing forward actions during machining. Pushing forward actions includes “feeding when lathe chuck is open” and “lathe chuck is close in machining”.

The signal logic will be handled according to PI11 setup.

g) Lathe door signal A7 (PLC input X37)

Door closed signal is used to control the speed of bar feeder in manual mode when lathe door is closed/open.

4.6.3 Signals from the bar feeder to the lathe

a) 24V DC power supply

All the signals from the bar feeder were powered by the 24V DC from the lathe. When the corresponding relay energized at the bar feeder, the 24V DC is passed through corresponding contact at bar feeder relay and return to lathe PLC. The lathe PLC hence receives bar feeder signals.

b) R1 alarm relay

When the bar feeder is in normal operation, the R1 relay is de-energized. In the event of an alarm or break in the emergency stop loop, this relay is energized and the signal will be sent out passing through the contact (NO or NC contact is used upon lathe requirement).

For safety reason, this signal should bring to a stop of the axis movements of the lathe as well as the rotation of the spindle.

c) R2 START signal relay

Relay R2 confirms the action of general part feed out or/and a new bar stock loading is finished. Refer to service parameter PI13, PI14, PI15 and PI16 for related set up.

d) R3 BAR END (end of bar) relay

When the pusher reaches BAR END position during feed out process, relay R3 energizes. This signal is used to indicate that the rest bar stock length is not long enough to machine a complete part according to part length set at P02.

Machining a workpiece which requires multiple chuck openings, this position must set according to the longest length of those different machining sections.

Refer to operation parameter P02, P10, P13 and service parameter PI17, PI18, PI19, PI20, PI32 and PI33 for further information.

e) R4 bar feeder in auto relay

This signal is present as soon as the bar feeder is switched into automatic mode (AUTO READY + AUTO START)

f) R5 INCHING relay

This relay energizes under circumstances described below during a bar change process:

1. The loading flag is moving forward for place the bar stock at FIRST FEED position (behind the vise jaws).
2. The pusher is moving forward for advancing the bar stock to TOP CUT position after insertion in the collet of the pusher.

For bar stocks without proper preparation or profiled material may struggle to enter the chuck. Generally the spindle rotates at slow speed when the new bar stock is passing through. For lathes not able to rotate the spindle with the chuck open this signal can be used as an external command to turn the spindle.

Refer to service parameter PI43 for more information.

4.7 SAFETY SWITCHES

The safety switches are used as reminders for user during operation and for safety reasons. They will impede any handling as long as the bar feeder is not in operational position.



Jumper on TB8 is removed when safety switches are wired.

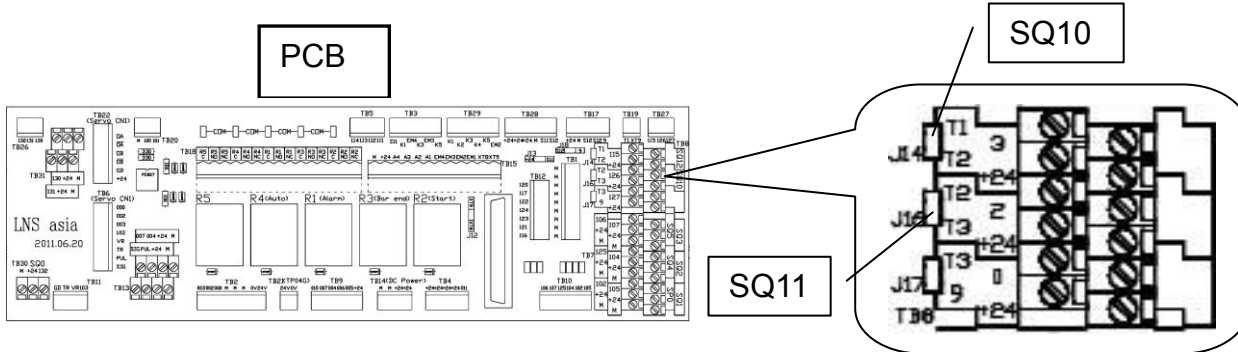

● **Main access cover safety switch (SQ11)**

The switch detects whether the main cover is closed or open. If the main access cover open the bar feeder will not start in AUTO mode.

When the cover is open, a signal will be sent to PLC input contact X20, An alarm message “Main cover is open” is displayed.

Please refer to 4.4 and 4.5 for wiring connection in the switch.

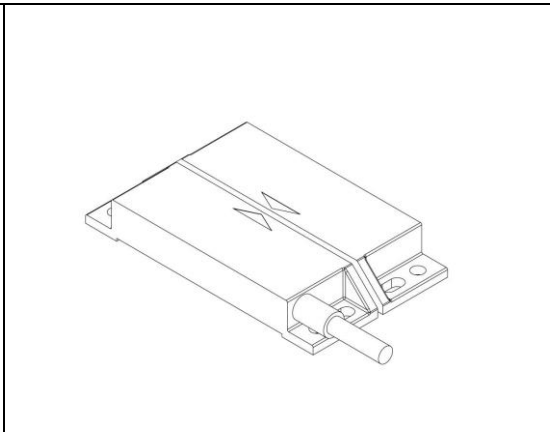

● **Optional Retraction safety switches (SQ10)**

The switches detect the position of bar feeder to ensure bar feeder is ready and the lathe can be put in production.

When bar feeder is ready, the safety switch SQ10 will operate as the figure A.

Following the procedures on 7.10.2, when bar feeder is moved, the safety switch SQ10 will operate as the figure B. A signal will be sent to PLC contact X21 and an alarm message “AL03” is displayed reminding the operator to move back bar feeder in the working position before starting the lathe in production.

Please refer to 4.4 and 4.5 for wire connection in the switch.

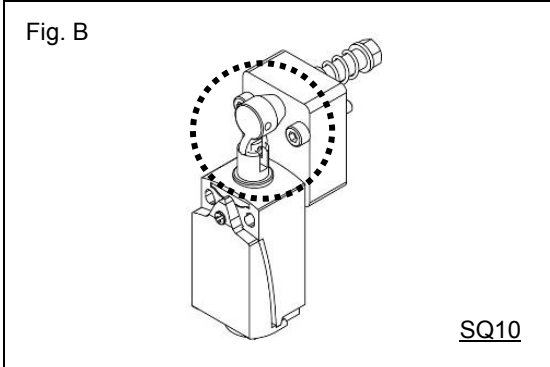
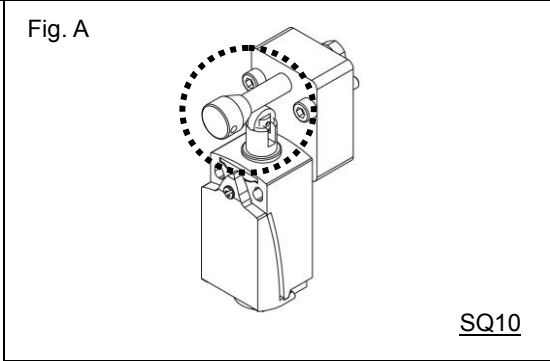

5 PNEUMATICS

5.1 GENERAL DESCRIPTION

The following automatic movements are activated by pneumatic system: channel opening or closing mechanism, vice (material clamping device), TOP CUT measurement device.

To guarantee an optimal operation of the bar feeder, a pressure of 5kgf/cm² is mandatory.

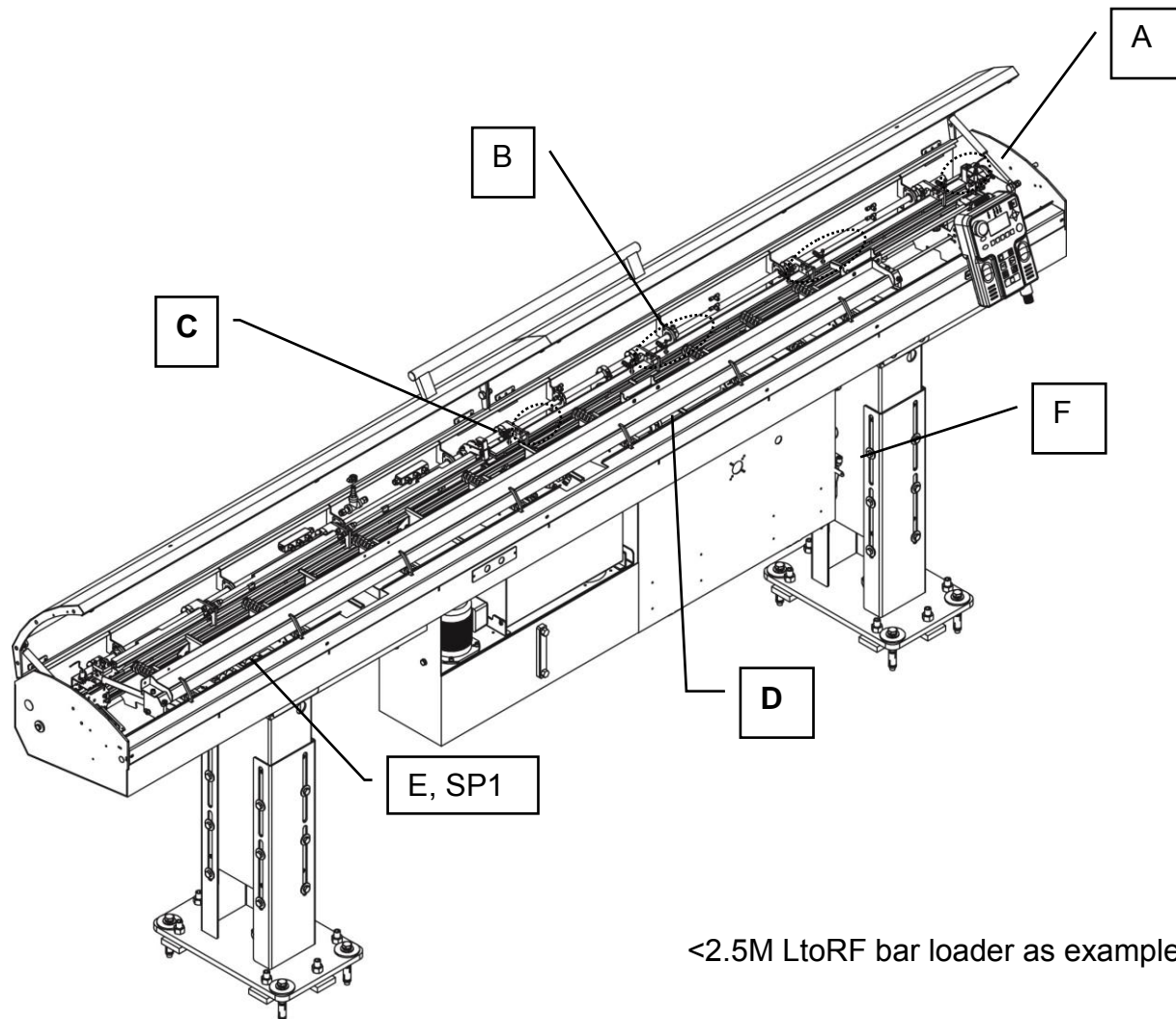

<2.5M LtoRF bar loader as example>

Designation	Part number	Description
A	C12115300	TOP CUT measurement device cylinder
B	C12115100	Sectional channel covers cylinder
C	C12110200	Material clamping device cylinder
D	C12115200	Channel opening/closing cylinder
E	LtoRF: XM1.27.A301A RtoLF: XM1.27.A302A	Air control unit (Invisible)
SP1	C11121400	Air pressure switch (Invisible)
F	RtoLF: XT032020210 LtoRF: XT032020220	Air filtering system

5.2 F.R.L. AIR FILTERING UNIT

The F.R.L. (Filtering-Regulation-Lubrication) combines air filtering, lubrication and regulation of the air pressure before it enters pneumatic system.

Air pressure required: 75-90 PSI (5-6bar) of shop air, preferably clean and dry.

5.2.1 Layout of the elements

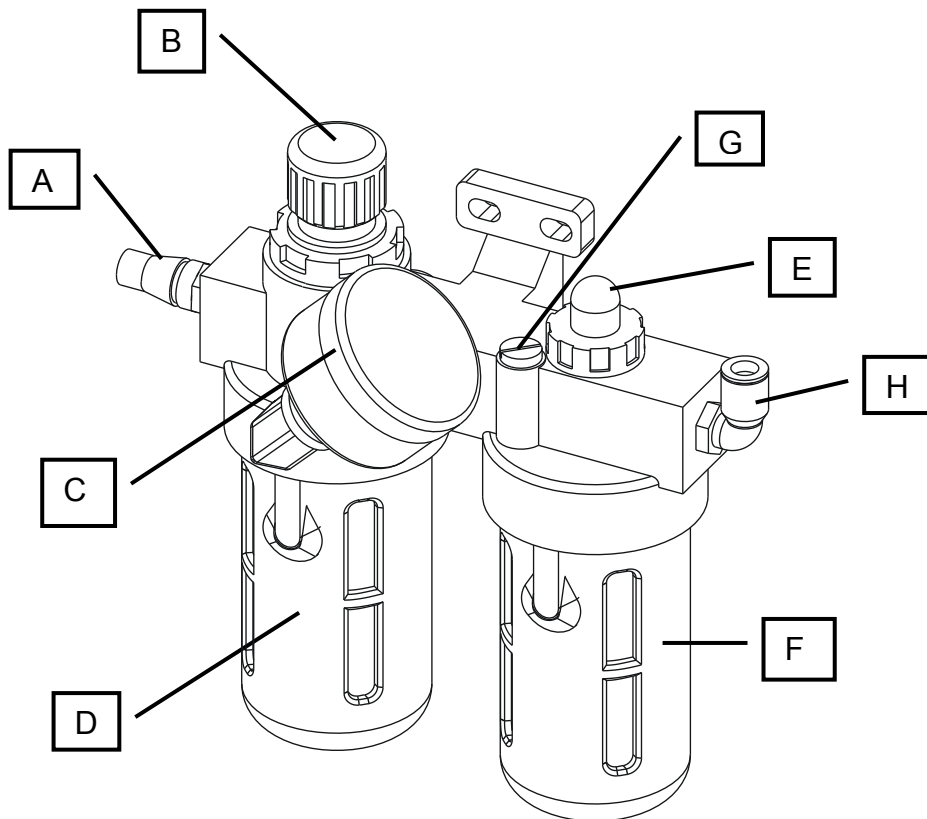

Designation	Part number	Description
A	C13120300	Air inlet
B	C11120100	Pressure regulator
C		Pressure gauge
D		Condensate collector
E		Lubricator
F		Oil cup
G		Oil refilling plug
H	C13110500	Regulated air outlet 8mm / G1/4 push-in fitting

5.2.2 Connection

Before connecting air to the bar feeder confirm the factory air pressure is not larger than 120 PSI (8 bar). Connect air hose to F.R.L.

The pneumatic connection (C) is located behind the control cabinet.

For the pneumatic connection of the bar feed, the customer must provide an air hose with an inside diameter of 3/8" (9.5 mm).

Provide an air hose long enough to allow the complete travel (500 mm) of the retraction system.

When the hose is connected, it should not lie on the ground for safety reasons and to prevent damaged to the hose.

1. Place clamp (A) around hose (B).
2. Insert fitting (C) into hose.
3. Tighten the collar (A) to make it airtight.

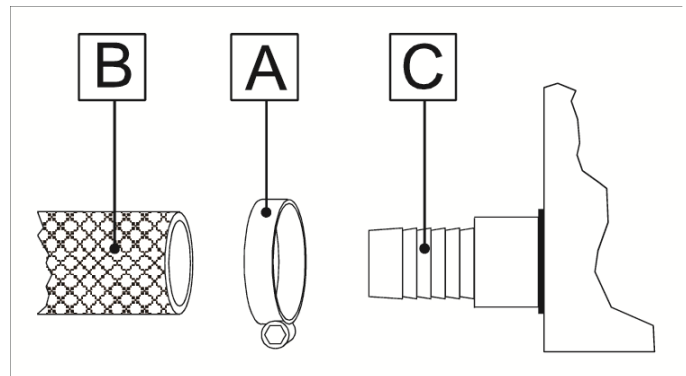

5.2.3 Settings

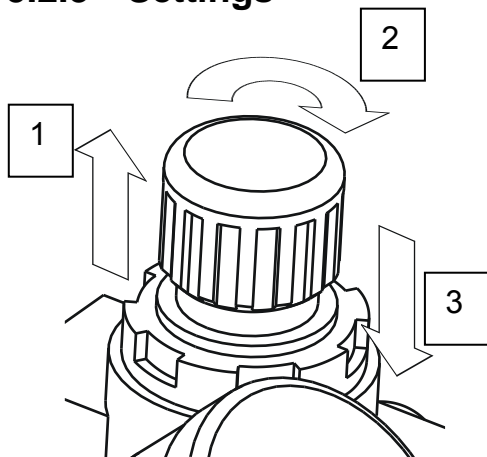

1. Unlocking the adjusting knob by pulling it upward.
2. To increase the pressure, turn the knob clockwise. To decrease the pressure, turn it counter clockwise. The operational pressure should be kept at 5 bar.
3. When the setting is finished, lock the knob by pressing it downward.

5.3 SOLENOID VALVE MANIFOLD

The solenoid valve manifold is mounted on the side of the electrical cabinet. It consists of a bank of electro-valves and an air pressure switch. To access the valves remove the protection cover. Valves can be activated manually.

5.3.1 Layout of the elements

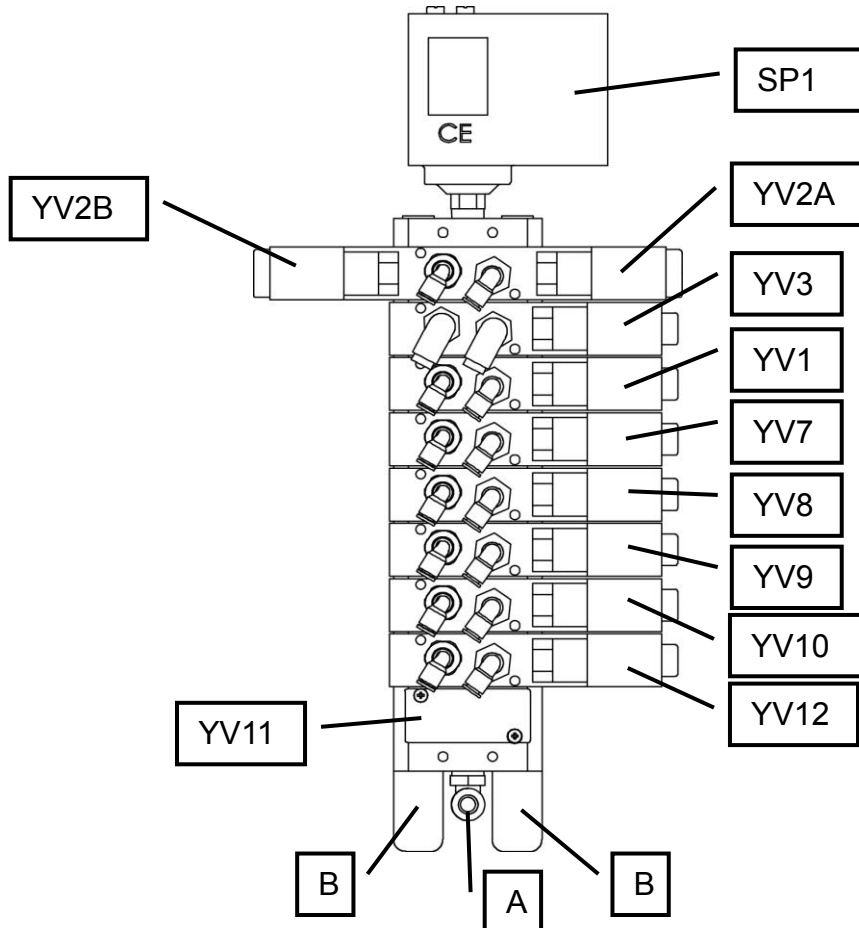

<12' LtoRF bar loader as example>

Designation	Output	Part no	Description
A		C13110500	φ8mm air inlet (from F.R.L. combination)
B		C14120200	Air outlet / silencers
SP1	X11	C11121400	Pressure switch (PE converter)
YV3	Y10	C1110100	Material clamping device (vice)
YV1	Y04		TOP CUT measuring device
YV7	Y07		1 st channel cover
YV8	Y15		2 nd channel cover
YV9	Y16		3 rd channel cover
YV10	Y14		4 th channel cover
YV11	Y17		2 nd front rest (Option)
YV12	Y26		5 th channel cover
YV2A	Y05		C11110200
YV2B	Y06		Guiding channel closing

5.3.2 Solenoid valve

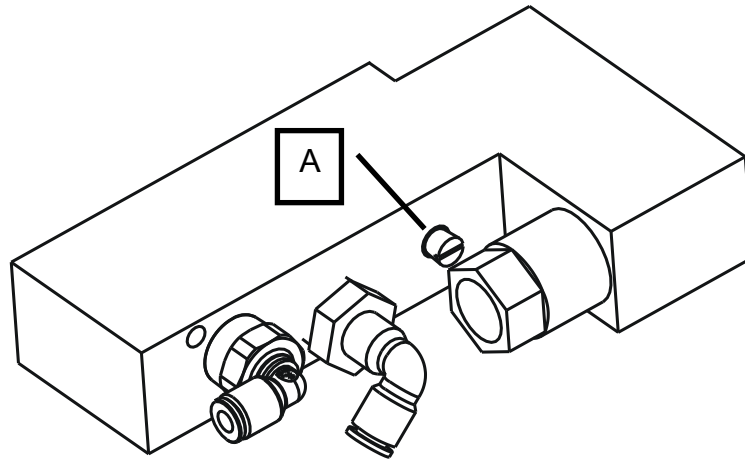

Directly controlled by the PLC, the solenoid valves activate the cylinders.
To manually activate the air valve press button A.

Attention!

Activating valves requires special attention to prevent bodily injury or components damage.

This button could be kept in the activation position by pressing it down and turning 90° clockwise. This position could be released by turning it 90° counter clockwise. This device is proved to be useful during testing or connection. Normal pneumatic cylinder returns to its original position when releasing the button (except for pneumatic cylinder activated by double-effect solenoid valve).

5.3.3 Air pressure switch, SP1

To guarantee the compressed air is supplied to the bar feeder the pressure switch confirms the pressure is sufficient.

The pressure switch engages when the pressure is larger than 60 PSI (4 bar). If the pressure is below 60 PSI, the switch will disengage and the emergency stop circuit will be interrupted. An alarm AL05 will be displayed on the HMI screen.

Settings of operating pressure range

1. Set the operating pressure at 60 PSI (4 bar) with screw A
The pressure switch will sense the operating pressure within a few seconds.
2. Set the lower pressure limit with screw B.

This setup will define when the pressure switch senses an abnormal pressure drop and generate a low pressure alarm.

Factory setup is: 43 PSI (3 bar).

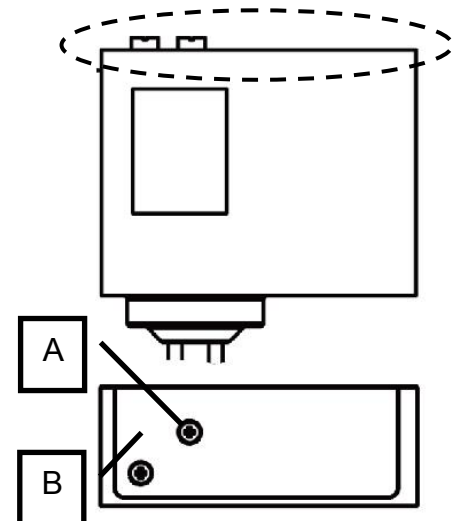

5.4 MAINTENANCE

The pneumatic system should be regularly maintained in order to ensure the system is powered by qualified compressed air. We recommend the user to check the F.R.L. combination once a week as instructed below.

1. Check the condensate collector:

The condensate collector monitors the compressed air quality. A qualified air should not produce any condensate inside the collector.

The collector has an automatic drain plug. When there is no pressure inside the F.R.L. system, the drain plug is activated by the spring and the condensate released.

Manual drainage: When condensate is found inside the collector drain the condensate by pushing up the plug to open the drain plug and drain.

2. Check the lubricator:

The oil consumption varies with the bar feeder applications. The oil level should not exceed half of the oil cup. It is recommended to use oil ISO VG 32. When the oil is less than 30%, follow the procedures below to refill it.

Steps:

1. Turn off air supply from the source
2. Disconnect the air inlet air hose.
3. Remove the plug and fill the oil up to the position shown on the figure (around 90ml).
4. For the best performance, the oil should drop every 10 cylinder operation. Set the amount of lubrication by using opening and closing the guiding channel of the bar feeder. In manual

mode press  and  on the remote control.

5. Connect the air inlet hose and turn air source back on.

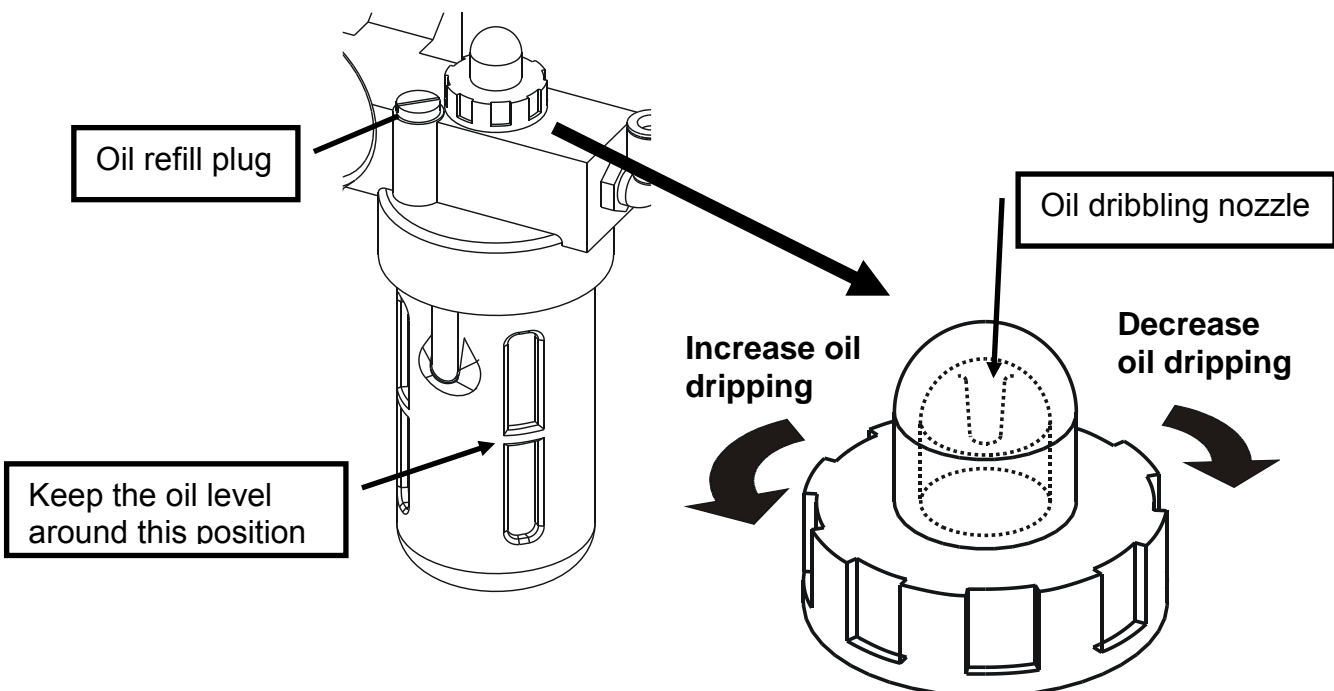

5.5 PNEUMATIC DIAGRAMS

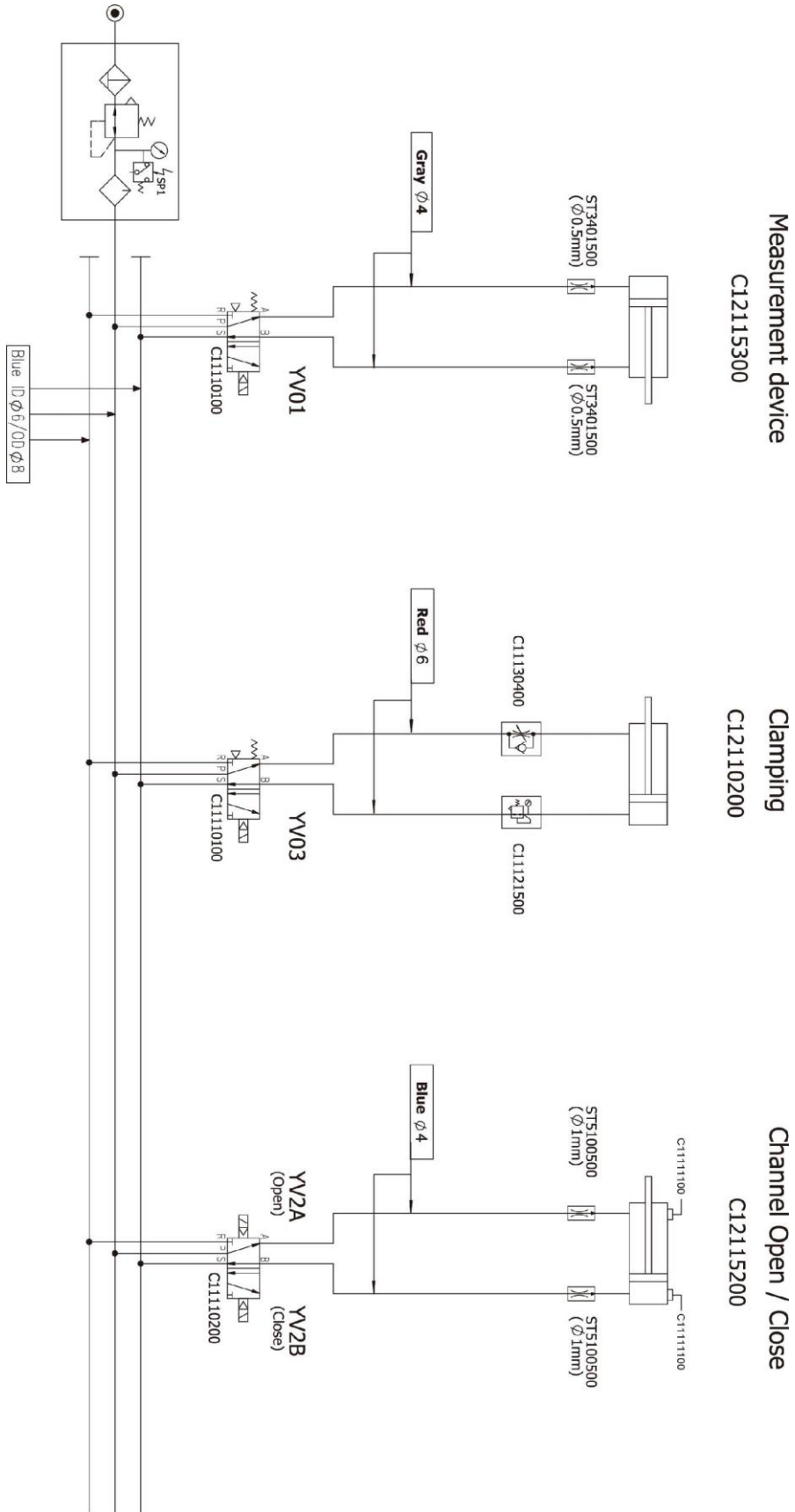

Pneumatic diagrams: XM1.27.P003A

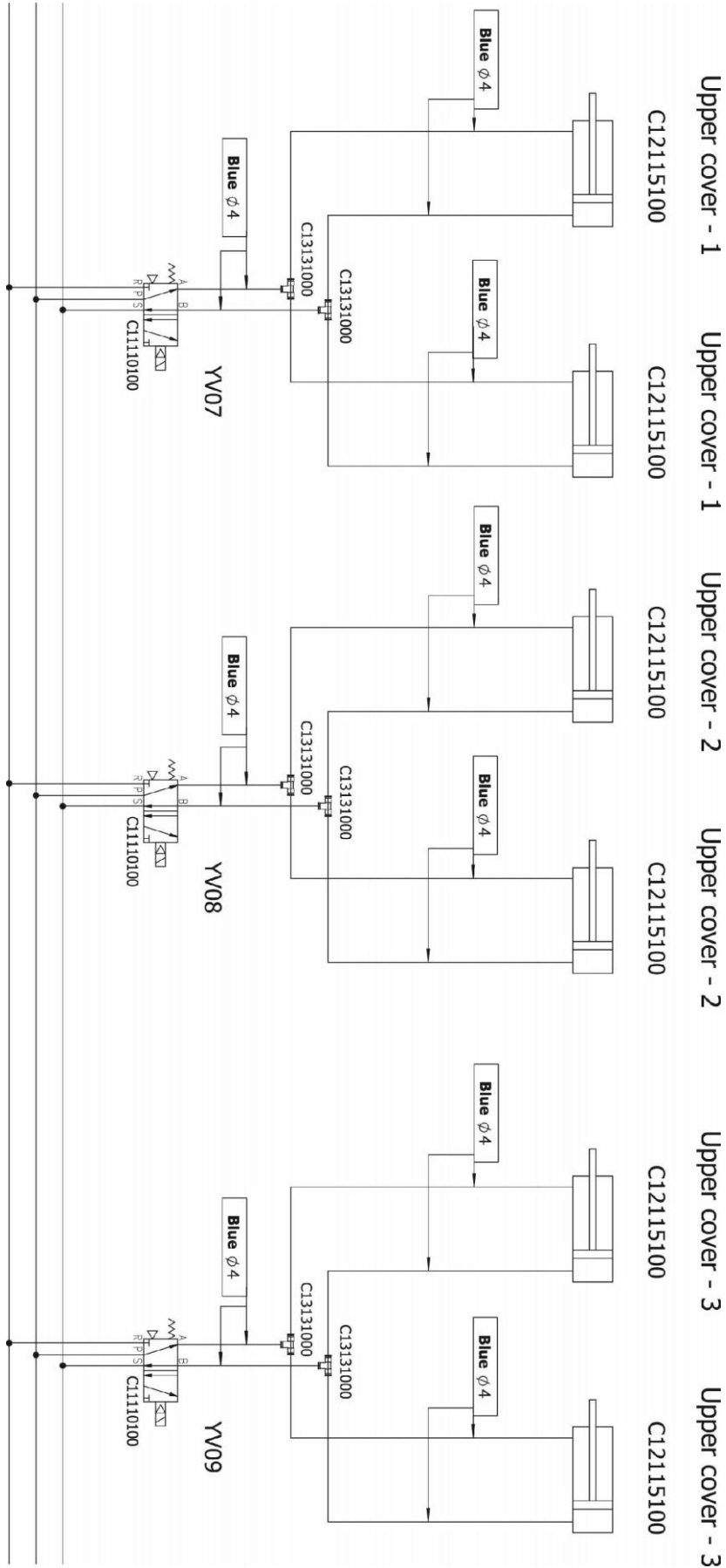

Pneumatic diagrams: XM1.27.P003A

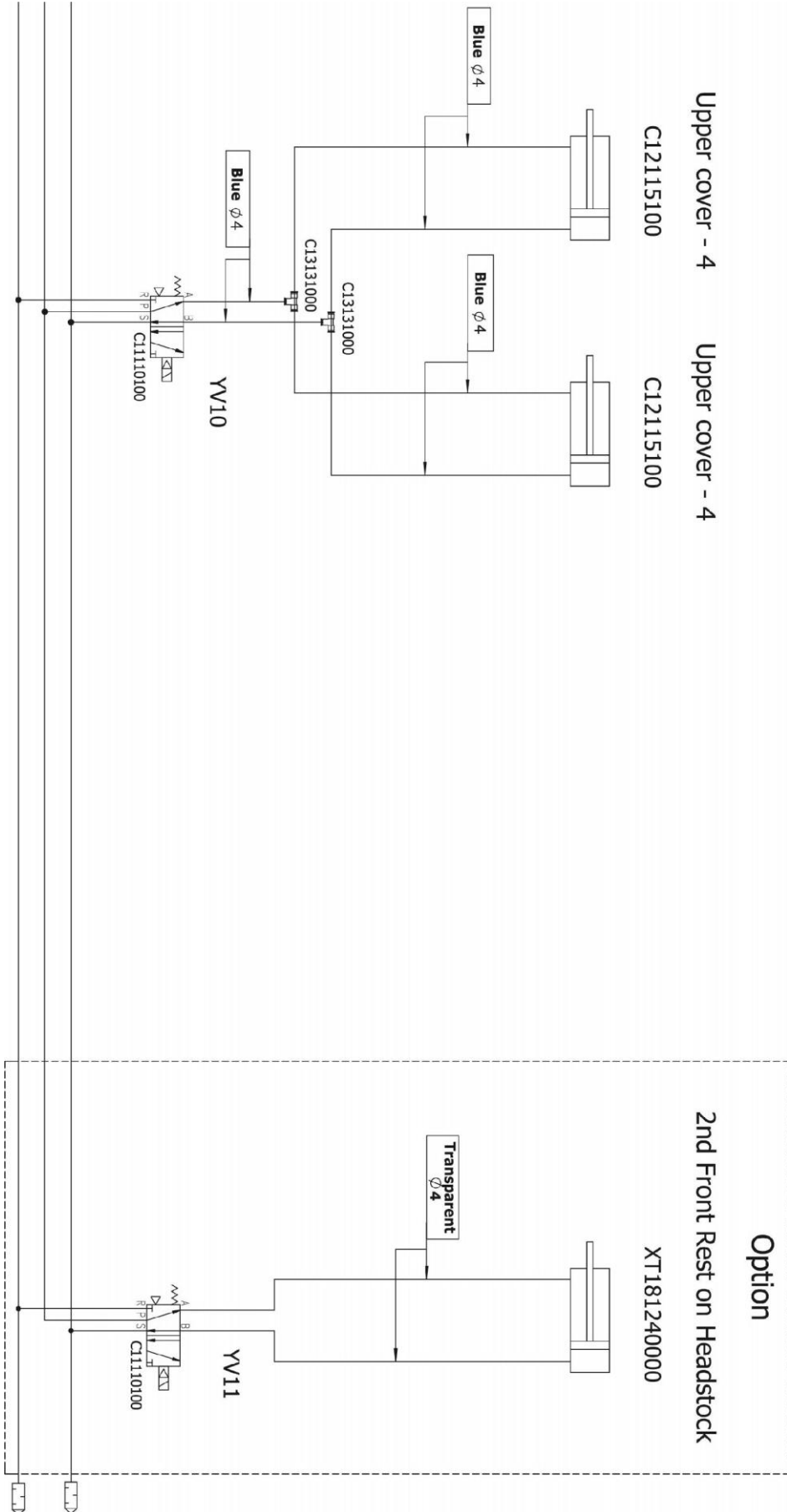

Pneumatic diagrams: XM1.27.P003A

6 HYDRAULICS

6.1 GENERAL DESCRIPTIONS

The hydraulic pump injects the oil into the guiding channels to provide the oil support necessary to obtain a hydrodynamic support of the bar in rotation.

This will allow:

1. Keeping the bar stock positioned at central of the channel.
2. Reducing friction between the bar in rotation and the guiding channel this not marking the surface of the bar.
3. To absorb the vibration created during high rpm machining.

6.2 LAYOUT OF THE ELEMENTS

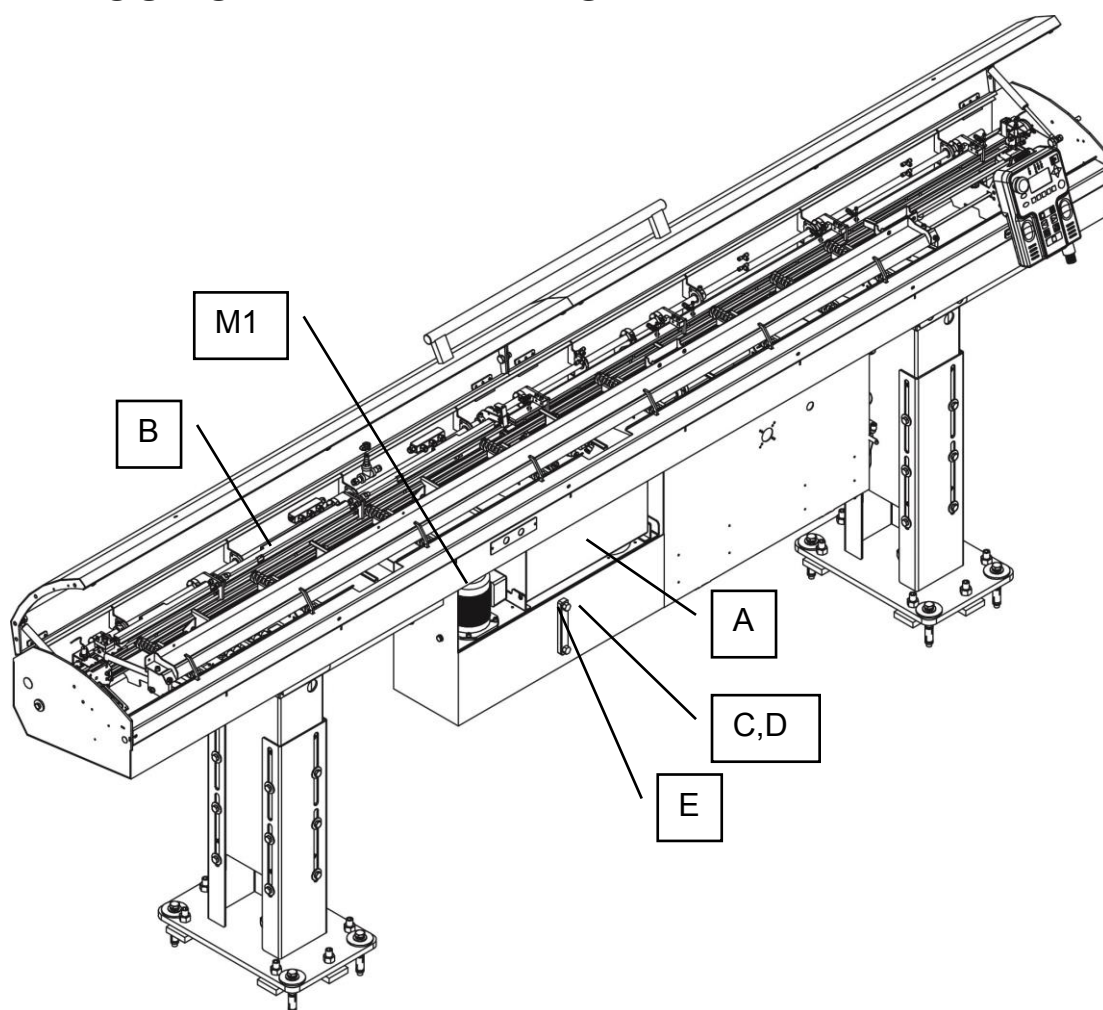

Designation	Part number	Description
A	X135010000xx	Remnant tray
B	-	Guiding channels
C	-	Hydraulic tank
D	C14110300	Drain plug (underneath the oil tank)
E	C17120400	Oil level indicator
M1	XT135050000	Hydraulic pump motor

6.3 DESCRIPTIONS OF THE ELEMENTS

6.3.1 Hydraulic pump motor, M1

The hydraulic pump is powered by 3 phases 220V AC. It powered on immediately when conditions below are satisfied:

1. Bar feeder is in automatic mode.
2. Guiding channel is closed.

If one of the following conditions is fulfilled, the hydraulic pump will immediately turn OFF:

1. Bar feeder is switched to manual mode.
2. Guiding channel is opened.
3. Emergency Stop line open or any other alarm condition occurs

6.3.2 Remnant tray

The tray collects remnants extracted from the pusher collet. It is located between the bar feeder body and oil tank. The maximum remnant length allowed is 380mm. The minimum is 50 mm.

The capacity of the tray depends on remnant diameter and length. The tray should be regularly checked and emptied to ensure the tray is not overfilled. An overfilled remnant tray might cause the following issues :

1. The oil draining out from the bar feeder to the tank may be interrupted and spill out.
2. The remnants might be lying between the material clamping device space and interfere with the next bar stock insertion or loading.
3. The tray may be too heavy to empty.

Remnants accumulation should remain below the cutout in the remnant tray.

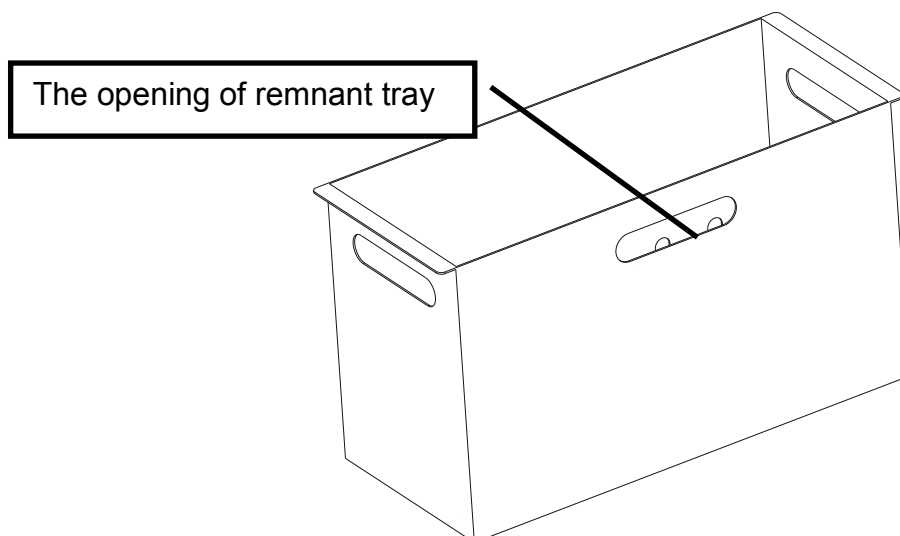

6.3.3 Oil filling and draining

The bar feeder is delivered without oil. Hydraulic oil of any brand name must be provided by the customer. The oil should be filled into bar feeder before running. Oil specifications see below.

Hydraulic oil capacity: 7.4 gallons (28 liters)

Filling the tank:

Slowly pour the oil into the oil tank directly as shown. The oil level should be kept around H mark on the level indicator when the hydraulic pump is not running.

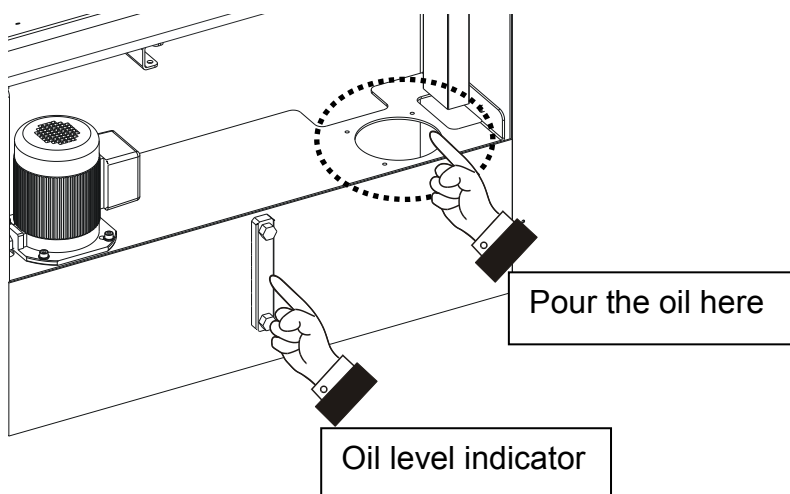

	Viscosity index (CST@ 40°C / 104°F)
ISO VG 68	61.2 ~ 74.8
ISO VG 100	90.0 ~ 110

6.4 MAINTENANCE

The hydraulic oil quality may deteriorate with the bar feeder running continuously. The cutting chips and sludge on bottom of the oil tank will be pumped into the hydraulic system thus causing eventual damage to the hydraulic pump. Dirty bar stock will accelerate oil contamination. Therefore depending on the cleanness of the bars it is recommended to drain and clean the oil tank at least once every 6 to 8 months.

Please follow the procedures below:

1. Power OFF the bar feeder system. Verify that most of the oil returned to oil tank.
2. Remove the remnant tray.
3. Place a container with sufficient capacity (minimum: 7.4 gallons [28 liters]) underneath the drain plug..
4. Remove the drain plug and drain the oil.
5. When the oil tank is empty, clean the sludge inside the tank and bar feeder.
6. Clean the drain plug. Apply the seal on the plug and screw the drain plug back in.
7. Refill the tank with new oil and according to chapter 6.3.4 until the level indicates oil level at H. Confirm there is no leaks from the drain plug.
8. Install the remnant tray back.

7 GENERAL DESCRIPTION

7.1 SCREW TYPE LOADING SYSTEM

The screw type loading system includes loading motor, loading screws and the axis of rotation and so forth. The loading screw is able to storage and move bars. This system is suitable for loading thinner material. Only one bar is allowed to put in each clearance and it should be put at the same position of each loading screw. The loading motor drives the rotation of loading screws so it allows one piece unloading per revolution.

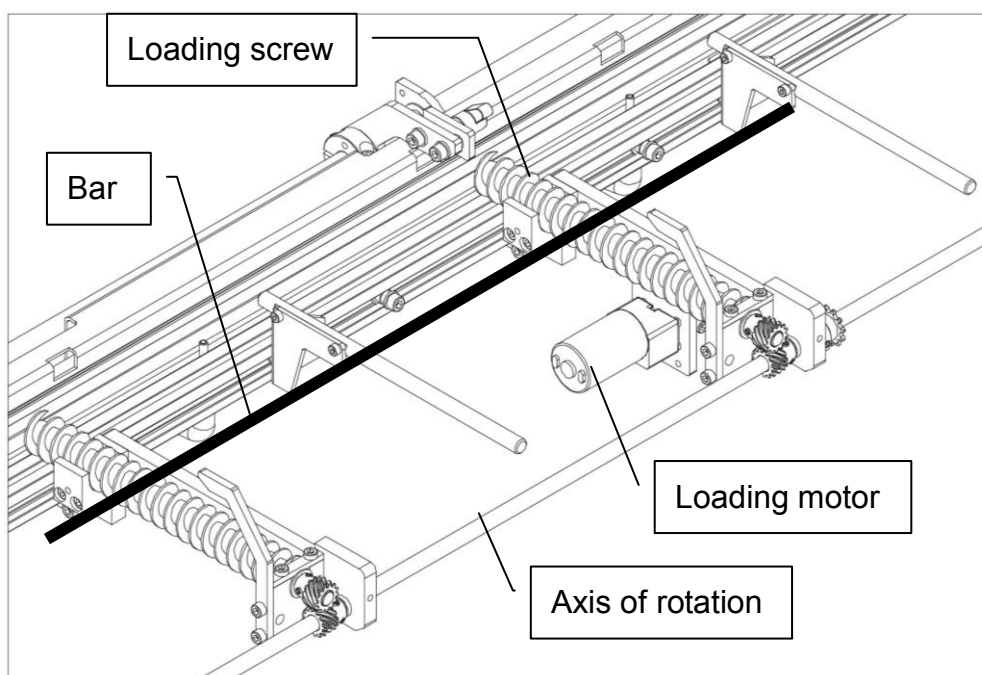

It's able to advance or reverse the loading screws. Normally, the screws go forward to guiding channel for bar loading. In response to operation required, it also offers a function to invert materials backward.

These two buttons are only available in **manual mode**. Use the button to load or unload bar stocks.

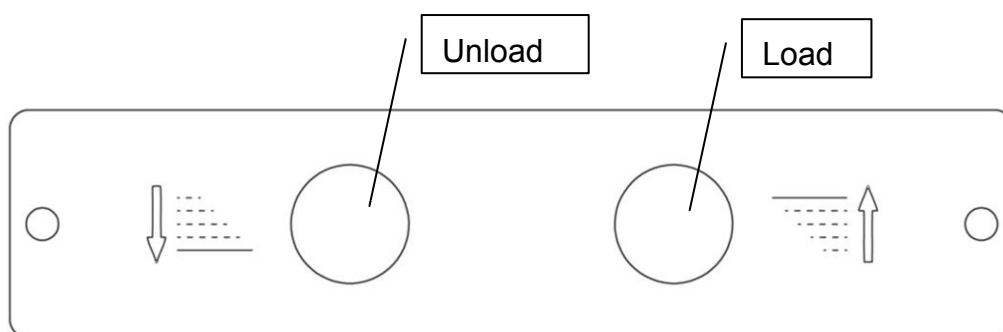

7.2 GUIDING SYSTEM

7.2.1 Channel and channel cover

The guiding system offers functions below:

1. To keep the pusher at the central of the guiding channel axis.
2. To house the moving/rotating components inside.
3. To seal the section of guiding channel with oil injected hence keep the hydraulic system working performance.

The unit will be installed with a dual size channel which combined two dimensions in one for different applications. The appropriate size of pusher sets will also come along with the specification of channel. Each dimension of channel caters for a range of bar diameters. For an optimum guiding and the best performance, it is recommended to keep 1mm clearance between bar stock and channel.

The channel cover is made of aluminum, formed in two long pieces and controlled by pneumatic system. It's designed to slightly open in sectional during feeding process. Depends on the model (2.0M, 2.5M, 3.2M, 12' or 4.0M), it's structured in two, three, four or five sections.

7.2.1.1 Channel set

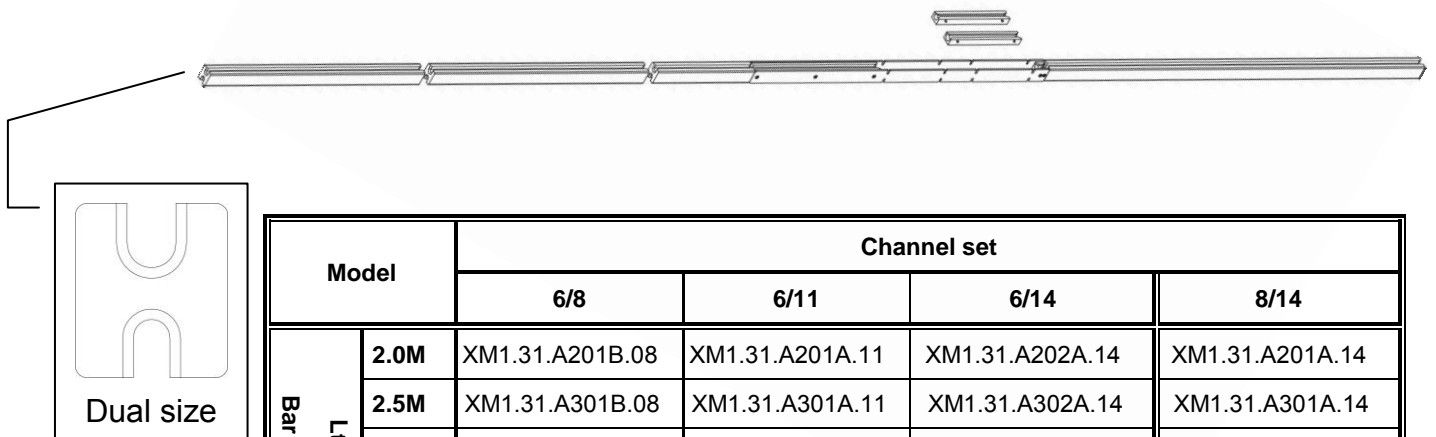

Model		Channel set				
		6/8	6/11	6/14	8/14	
Bar feeder	LtoRF	2.0M	XM1.31.A201B.08	XM1.31.A201A.11	XM1.31.A202A.14	XM1.31.A201A.14
		2.5M	XM1.31.A301B.08	XM1.31.A301A.11	XM1.31.A302A.14	XM1.31.A301A.14
		3.2M	XM1.31.A401B.08	XM1.31.A401A.11	XM1.31.A402A.14	XM1.31.A401A.14
		12'	XM1.31.A501A.08	XM1.31.A501A.11	XM1.31.A502A.14	XM1.31.A501A.14
		4.0M	XM1.31.A601A.08	XM1.31.A601A.11	XM1.31.A602A.14	XM1.31.A601A.14
Bar feeder	RtoLF	2.0M	XM1.31.A203A.08	XM1.31.A203A.11	XM1.31.A203A.14	XM1.31.A203A.14
		2.5M	XM1.31.A303A.08	XM1.31.A303A.11	XM1.31.A303A.14	XM1.31.A303A.14
		3.2M	XM1.31.A403A.08	XM1.31.A403A.11	XM1.31.A403A.14	XM1.31.A403A.14
		12'	XM1.31.A503A.08	XM1.31.A503A.11	XM1.31.A503A.14	XM1.31.A503A.14
		4.0M	XM1.31.A603A.08	XM1.31.A603A.11	XM1.31.A603A.14	XM1.31.A603A.14

7.2.1.2 Bridge channel

The bridge channel is used for smaller and soft material. During feeding process, the smaller material will bend easily when it pass through above the remnant box. To avoid the material getting bend, user can place a bridge channel at the entrance of the remnant box to shorten the distance which is no support.

The bridge channel is only used for Ø6 and Ø8 channel.

* Notice: The length of remnant would be limited if the bridge channel is installed on the machine.

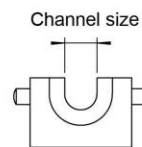
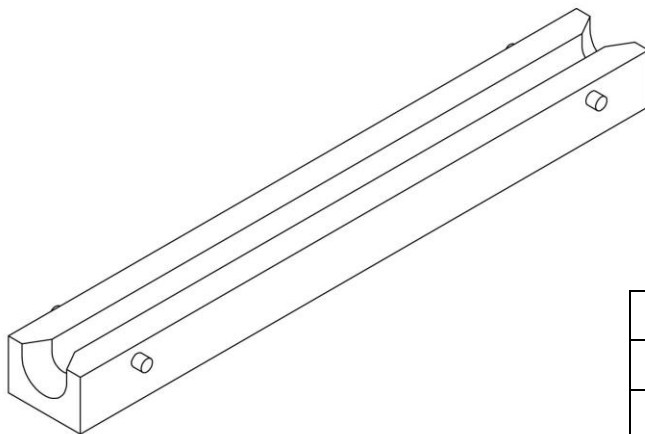

Bridge channel	Part no.
Ø6	XM1.31.A003A.06
Ø8	XM1.31.A003A.08

7.2.1.3 Auxiliary thin bar loading plate

This component is installed in home position. It is designed for vary small and thin material (about 1mm) to prevent it from getting stuck when loading.

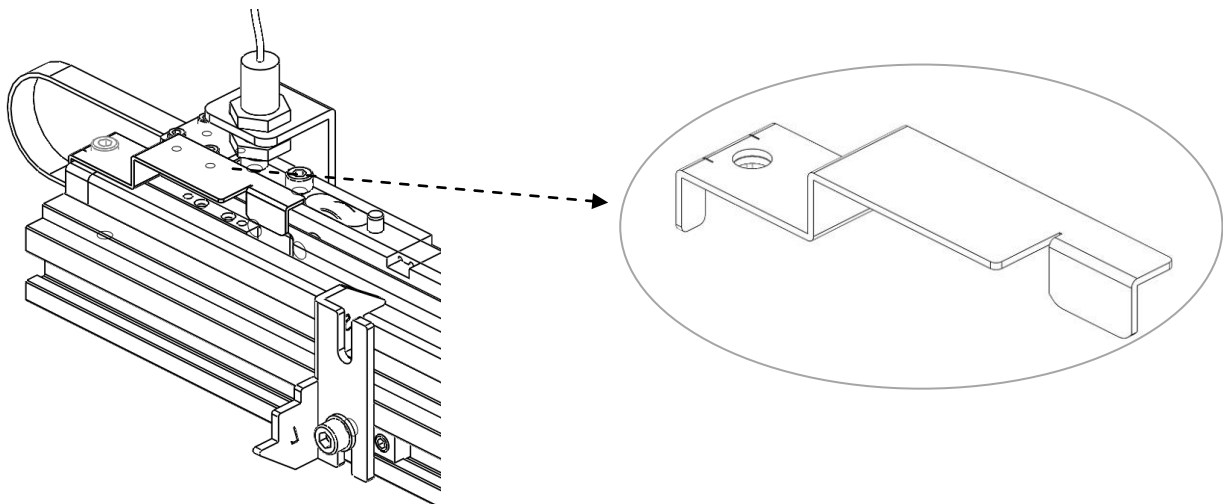

7.2.1.4 Sectional channel cover

The sectional channel cover will slightly open for pusher passing through when the pusher flag is detected by each of the sensor on cover. This design is specific to thin materials for an optimally closed guiding.

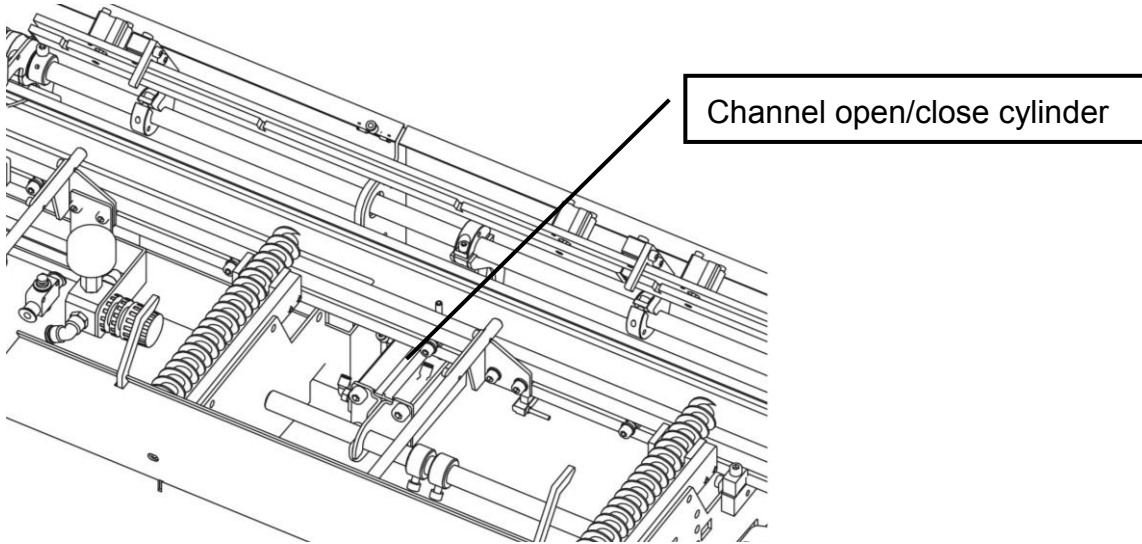

Take LtoR, 2.5M bar feeder with 3 sectional channel cover as an example:

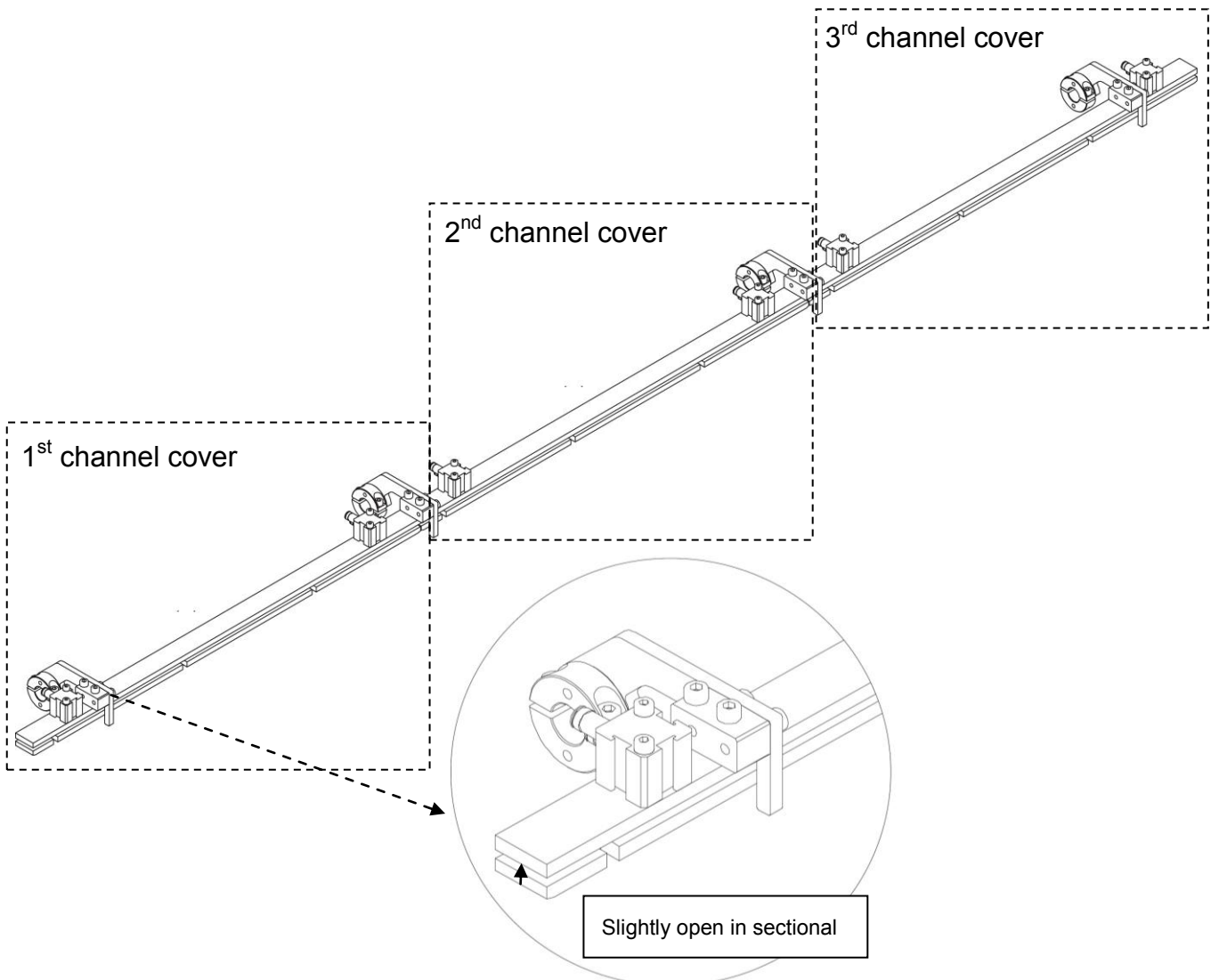

7.2.2 Tube

The front tube or telescopic tube functions as an extension of guiding channel. It performs the guiding between bar feeding system and lathe.

7.2.2.1 Joint pipe (Fixed)

The joint pipe is a tube with fixed length. It serves specifically for small spindle type lathes. Its inner is sized to match the guiding channel so it shall be replaced when the guiding elements are changed.

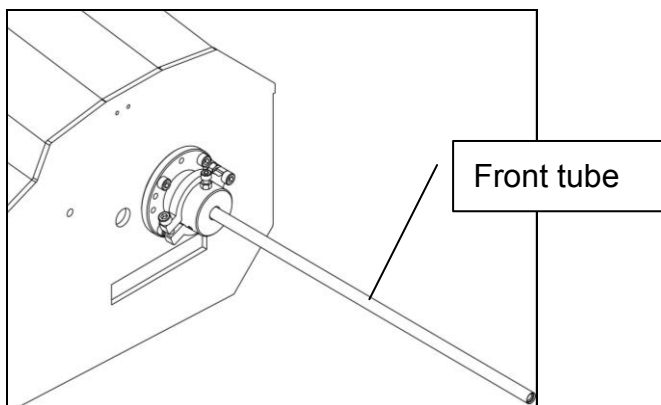

Front tube		Channel size (mm)	Pusher size (mm)
Part no.	ID x OD x L (mm)		
017.23.008/530	Ø6.4 x Ø8 L=530mm	Ø6	Ø5
112.03.634B	Ø7 x Ø12 L=1000mm	Ø6	Ø5
112.03.644B	Ø8 x Ø12 L=1000mm	Ø8	Ø7
112.03.454	Ø11 x Ø18 L=1000mm	Ø11	Ø10
112.03.464	Ø14 x Ø18 L=1000mm	Ø14	Ø13

7.3 PUSHER ASSEMBLY

The pusher assembly includes the loading flag, the long pusher (feeding pusher), the collet and collet adapter (depending on the collet type).

The loading flag is always connected to the belt drive whether the channel is open or closed. When the channel is closed, it follows the movement of the long pusher. When the channel is open, it mainly serves to position a bar stock to the insertion position.

The long pusher serves to control the bar stock movement either in the bar feeder or lathe spindle. When the channel is open, the long pusher is disengaged from the drive belt and lifted by the pusher hooks. When the channel is closed, the long pusher is connected to the drive belt.

Part of the long pusher is able to extend outside of bar feeder. During installation, it must be confirmed that the tip of long pusher is able to reach the back of the lathe chuck (end of bar).

Two pusher lengths are available:

Specification	Available length of pusher
Short pusher	830mm
Long pusher	1080mm (<i>Standard for USA</i>)

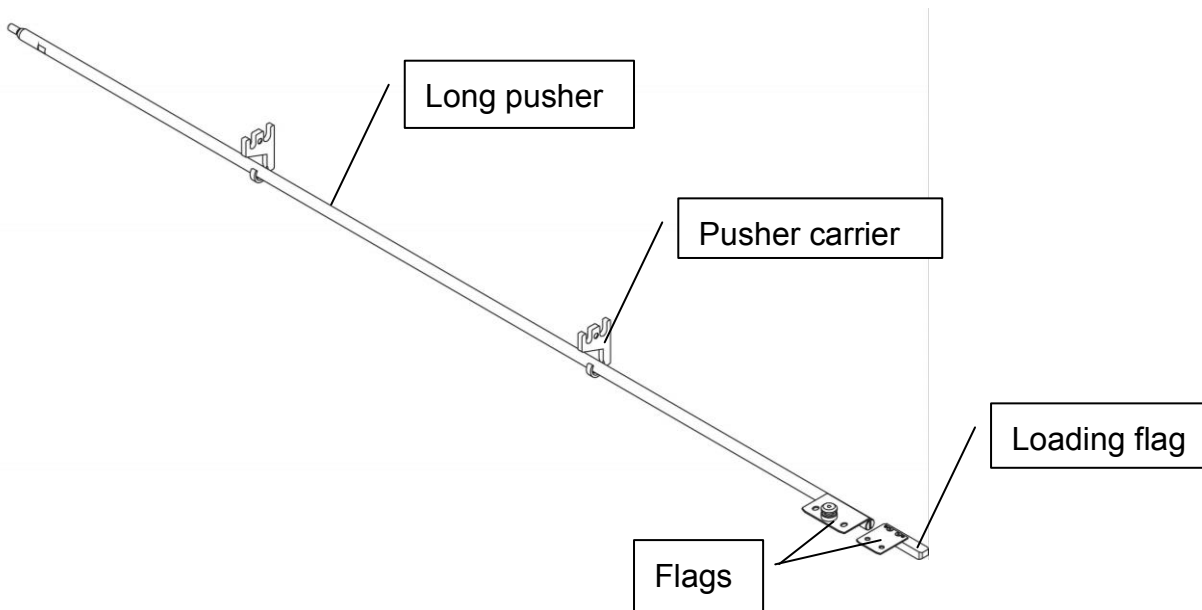

7.3.1 Pusher set selection guide



Note: The pusher diameter is 1 mm smaller than the diameter of the guiding channel.

Channel size

Pusher diameter

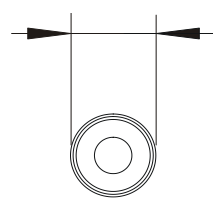
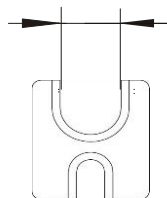

Ø (mm)	Pusher set			
	LtoRF Bar feeder		RtoLF Bar feeder	
	Short pusher	Long pusher (USA)	Short pusher	Long pusher (USA)
5	XM1.15.A051B.05	XM1.15.A005B.05	XM1.15.A052B.05	XM1.15.A006A.05
7	XM1.15.A051B.07	XM1.15.A005B.07	XM1.15.A052B.07	XM1.15.A006A.07
10	XM1.15.A051B.10	XM1.15.A005B.10	XM1.15.A052B.10	XM1.15.A006A.10
13	XM1.15.A051A.13	XM1.15.A005B.13	XM1.15.A052A.12	XM1.15.A006A.13



LtoRF Bar Feeder

RtoLF Bar Feeder

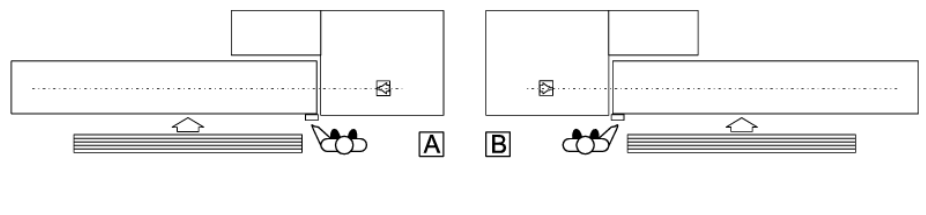

7.4 ROTATING SLEEVE

The rotating sleeve is mounted between the pusher body and the collet of the pusher.

This part is critical for the bar feed performance. A defective rotating sleeve could result in bar vibrations and noise. The user is strongly recommended to inspect its status regularly in order to keep the bar feeder running at the best performance. The rotating sleeve is a wear item, and LNS recommends keeping a spare on hand.

Part Number	Size
1.440	Ø 5.5
015.15.1064	Ø 7
015.031.013/100	Ø 10

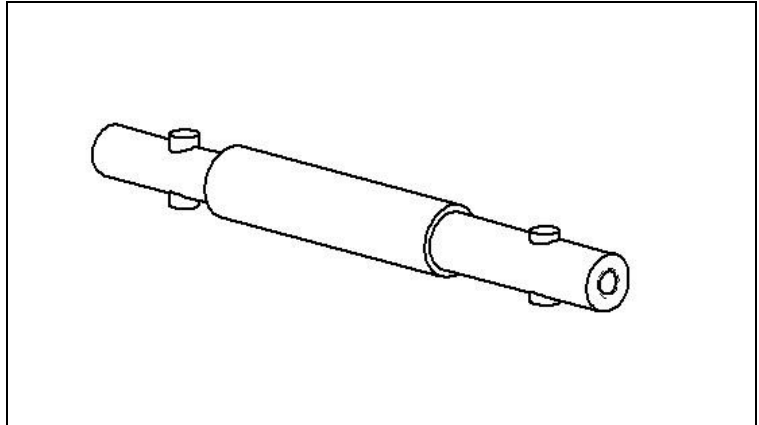

7.5 COLLET

The collet is link between the bar stock and the pusher. When the lathe spindle is turning, the bar clamped in the chuck of the lathe rotates at the same speed. The collet must be properly selected according to the bar stock diameter and shape.

The standard type collet is a cylinder with flexible jaws that are a friction fit to the bar stock. Each collet matches a specific bar stock dimension. For profiled bar stock, the collet inside diameter must be selected according to the diameter across the corners, unless the end of the bar is turned down to a round diameter (ideal). Refer to table paragraph 2.3 of the manual for diameter conversion.

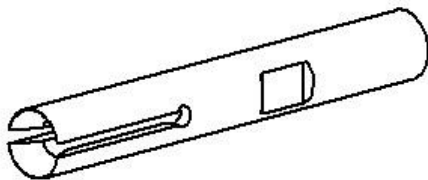

Collet part number	Channel size, mm	Rotating sleeve / collet adapter	Barstock dimension	
			Minimum diameter, mm	Maximum diameter, mm
1.648/05-xx.xx	6	1.440	0.80	4.00
15053/07-xx.xx	8	015.15.1064	2.00	5.55
15053/10-xx.xx	11	028.031.024	3.00	8.33
15053/12-xx.xx	14	028.031.044	5.00	11.11
15053/13-xx.xx	14	028.031.044	11.00	12.00

7.6 DIAMETER CHANGEOVER

The channel system is composed of the guiding channel set (chapter 7.2) and pusher set (chapter 7.3). Once the bar stock diameter is out of the guiding channel range a complete changeover is required that includes the guiding channel set, the pusher assembly and the hooks.



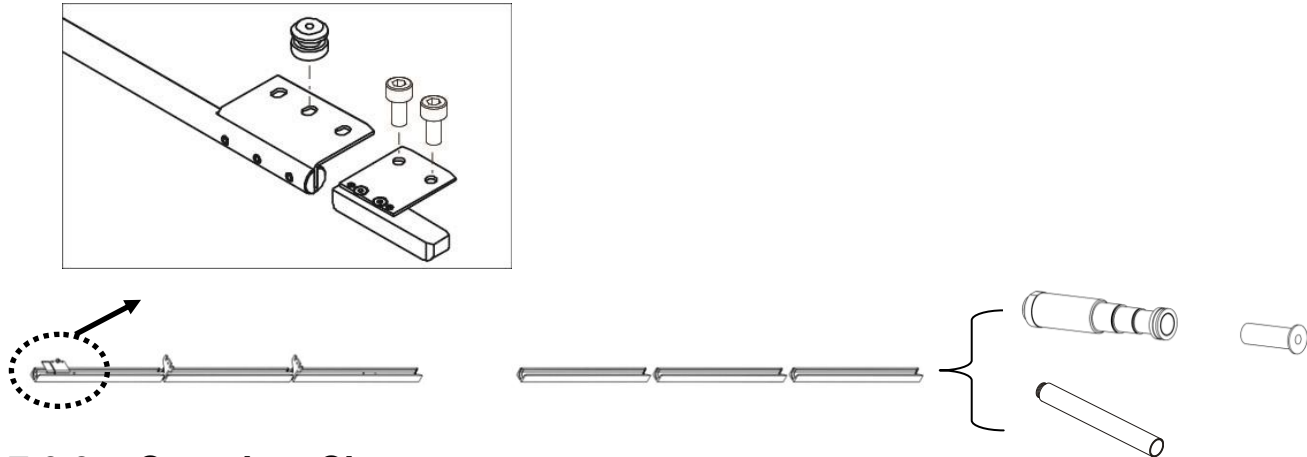

7.6.1 Layout of the elements



7.6.2 Complete Changeover



Please do not turn the power off of the bar feeder during a changeover to ensure the pusher position is read correctly and make sure there is no bar stock in the collet or inside the guiding channels.



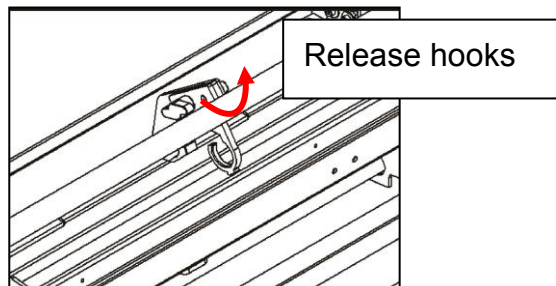
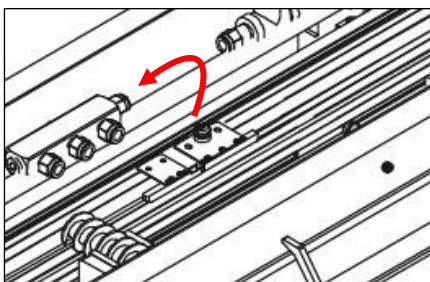

1. Press  to switch bar feeder into manual mode.
2. Press  to close channel and press  to advance the pusher through the vise.
3. Press  to open the guiding channel.
4. Press  Emergency Stop button to disable all functions and movements of the bar feeder.
5. Take out pusher, loading flag and remove pusher hooks.



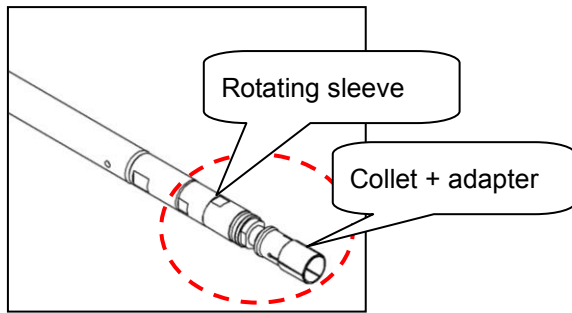



6. Remove the guiding channels, store in a clean location and install newly selected channels.

7. Install the appropriate rotating sleeve and collet with collet adapter (if necessary) on the pusher.



8. Install the loading flag and install the pusher corresponding to the guiding channel diameter. Lay the pusher back into the guiding channels (pusher diameter is 1mm smaller than the guiding channel diameter).
9. Install appropriate pusher hooks.
10. Release the Emergency Stop button  and press  to exit the emergency stop.
11. Press  to close the guiding channels and press  to move pusher back to its home position.
12. Using the HMI enter the channel size setup with parameter" GUIDING ELEMENT".
13. Install the corresponding spindle liner in the lathe and the tube described on chapter 7.2.2.
14. Adjust front rest to the new bar diameter.
15. The changeover is completed

Partial diameter changeover:

1. Follow the above steps 1 to 4.
2. Take out the pusher.
3. Replace the collet and collet adapter if required.
4. Put the pusher back into the guiding channels and lock the pusher in secure position.
5. Release the Emergency Stop button  and press  to exit the emergency stop.
6. Press  to close the guiding channels and press  to move pusher back to its home position.
7. Adjust 2'nd front rest to the new bar diameter (If there is equipped with the option).
8. Partial diameter changeover is complete.

7.7 BELT

7.7.1 Adjustment of the belt tension

The belt tension may require adjustment after running in production for extended period of time.

Check tension once every 6 months.

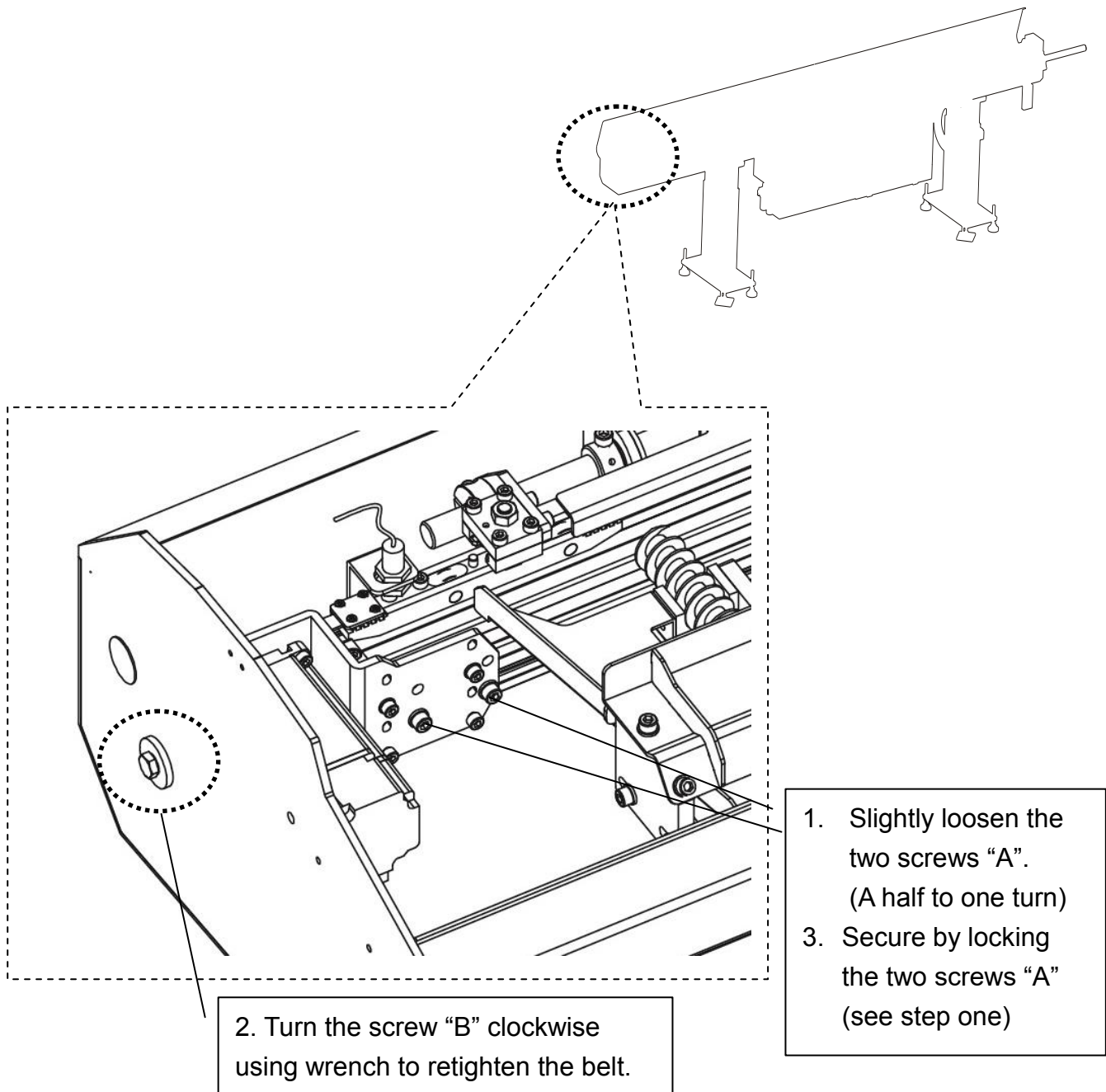

7.8 VISE (self-centering)

Vise (material clamping device) is used to hold the bar stock for insertion of the bar or extraction of the remnant. Independently of bar diameter or bar profile, the clamping system is self-centering. No adjustment is required. However for very small diameter or thin wall tubing the clamping pressure can be optimized.

7.8.1 Layout of the elements

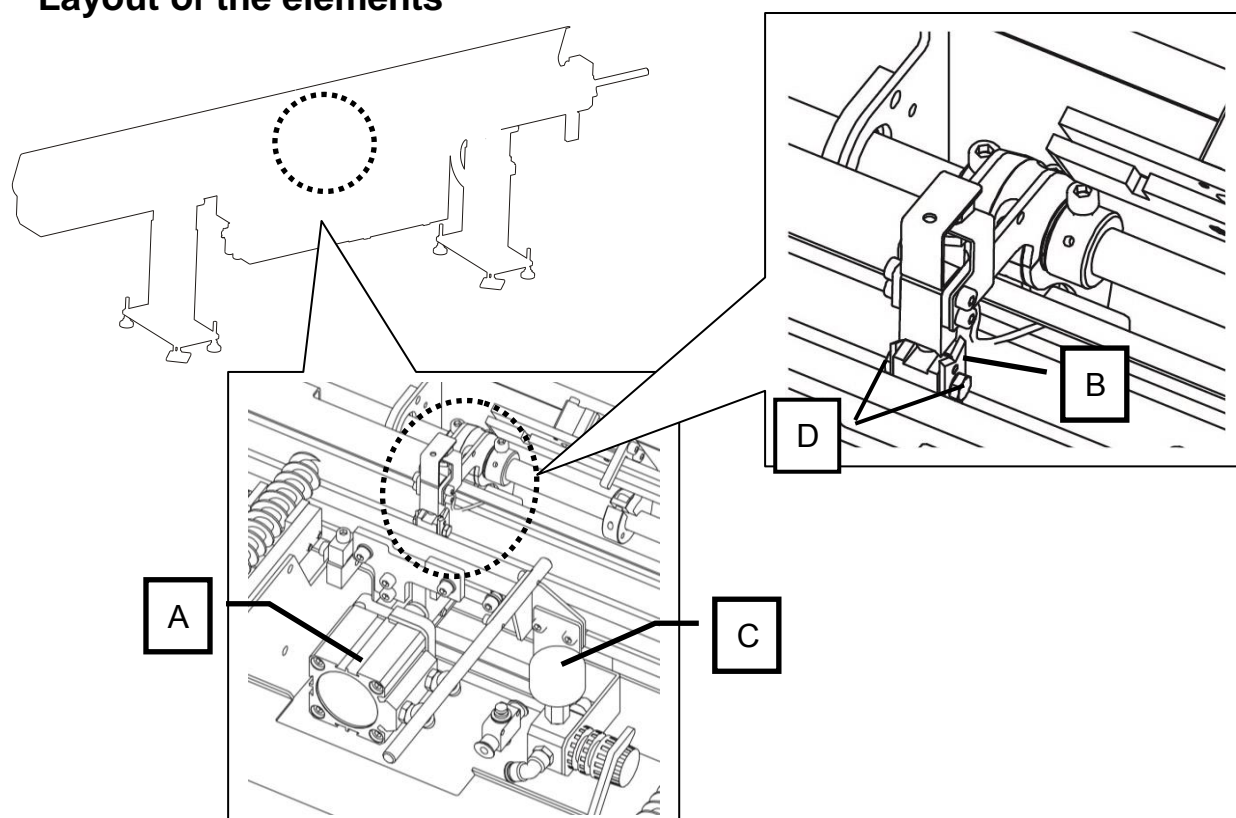

Designation	Part no.	Description
A	C12110200	Clamping device cylinder
B	XM1.22.P005C	Vise blades
C	LtoRF: XM1.22.A004A	Air regulator
	RtoLF: XM1.22.A005A	

7.8.2 Replacement of the blades

Attention: Use caution when replacing the blades. They are sharp and can cause harmful cuts. Wearing protective gloves is recommended.

The clamping blades must be replaced when worn out. Proceed as follows:

1. Unscrew the two screws (D) and remove the blades (B).
2. Install the new blades and lock the screws.

7.9 BAR MEASURING DEVICE

The term TOP CUT presents both the action and the position of the bar front end machining process for a newly loaded bar into the lathe. The purpose is to remove the unqualified surface at the end of the newly loaded bar to start machining a good part and as a correct reference for positioning the bar stock during machining. Generally this process will take place after a bar change sub-program. Depending on the tooling layout of the lathe this position could be adjusted to any position outside the lathe chuck. Generally 20 to 30 mm outside from the face of the chuck.

The bar feeder is designed to allow the loading of random length bars without any adjustment. The bar measuring device serves to receive the front end of the newly loaded bar. In automatic operation via a mechanism and a sensor it will detect the presence of the bar and the servo motor will automatically advance the front end of the bar to Top Cut position outside the face of the chuck. When the bar end reaches the pre-adjusted TOP CUT position (parameter P05), a confirmation signal (R2) is sent to the CNC lathe to resume the CNC program.

Since the bar measuring sensor is only activated by the front end of the newly loaded bar note that the TOP CUT distance is not dictated by the bar stock length. Once the bar feeder position is fixed (via parameter), the TOP CUT position is only related to the distance from the bar feeder to the face of the lathe chuck.

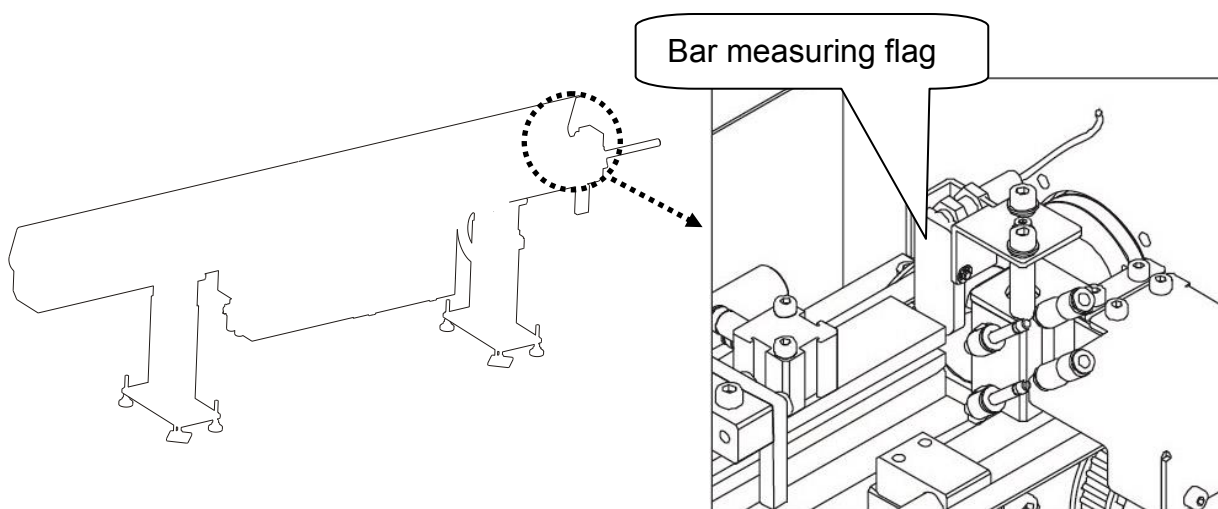

7.10 HEADSTOCK SYNCHRONIZATION DEVICE

Note: This device is required when the bar feeder is installed on **sliding headstock** (Swiss style) only. Its purpose is to detect any movement of the headstock and to prevent small diameter bars to buckle, bend or disconnect from the collet of pusher while the headstock is moving back and forth.

The synchronization device is mechanically connected to the machine headstock and has a built-in sensor to reading the movement of the sliding headstock. The pusher/bar stock movement is synchronized with the headstock movements during automatic mode.

During automatic mode, there are 2 conditions for the feeding system:

Headstock Synchronization:

When the collet of the lathe is closed the feeding system (pusher/bar stock) movement is synchronized with the headstock movements. When the collet is open the synchronization system is disabled while the servo drive maintains a reduced torque to keep the bar in contact with the cut-off tool and preventing short parts. This mode applies to Swiss type lathes only.

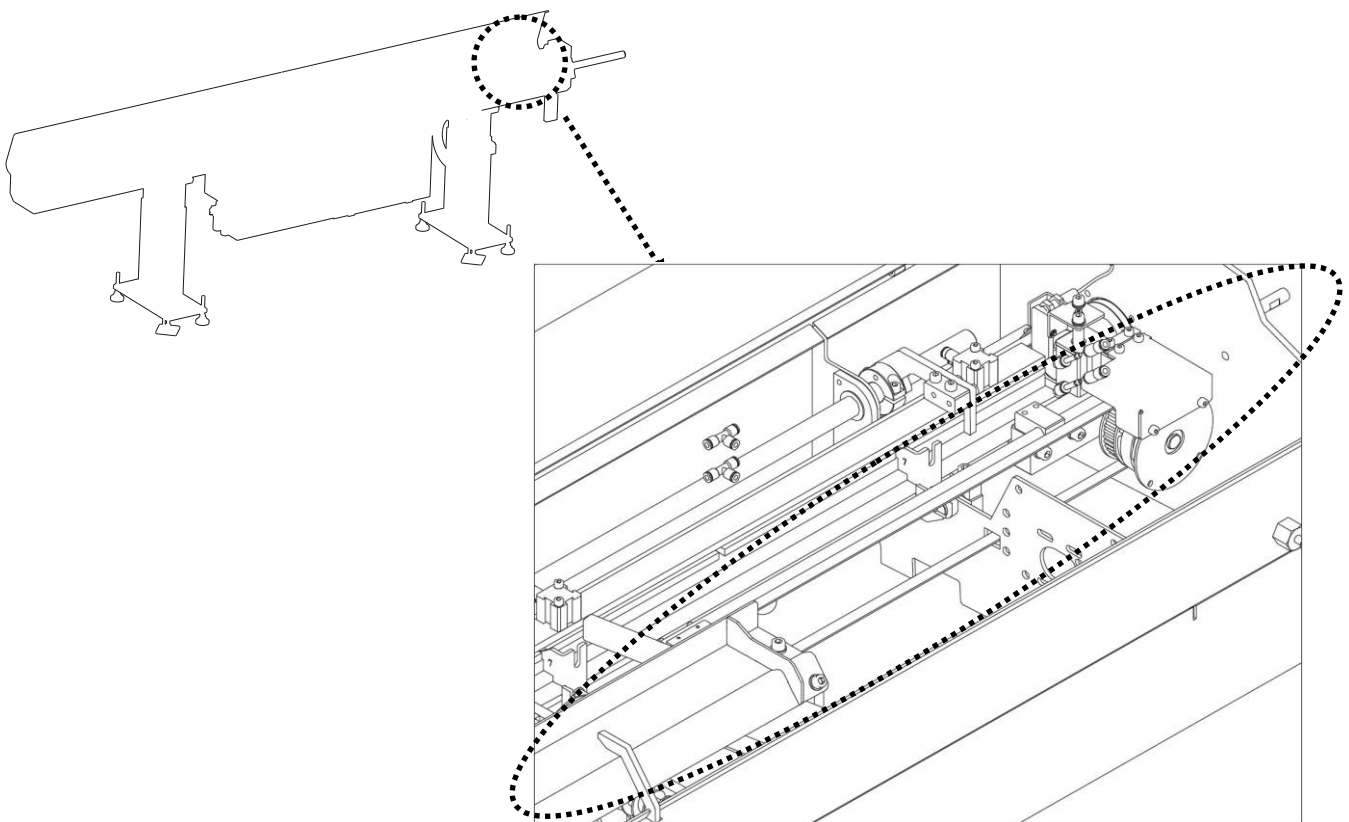

7.11 LATHE CONNECTING PARTS

Depending on the bar feed/machine configuration, various mechanical parts could be mounted between the bar feeder and the machine. Safety joint pipes or telescopic tubes for sliding headstock machines, additional support, covers, etc. are part of this mechanical interface. Please contact our office for further information.

Example:

The LNS joint pipe safety connection maintains a continuous connection between the GT 112-E and the machine sliding headstock. This feature allows the headstock to move forward to make parts without the danger of exposed bar stock. The inside diameters of these joint pipes match those of the bar feed's guide channels. They act as a combination spindle liner to reduce the gap inside the spindle, and additionally a safety connection that fully contains the rotating parts. The result is reduced vibration and bar oscillation within a critical and traditionally under-supported area. This GT 112-E feature improves part diameter tolerances, increases RPM, enhances surface finish and extends tool life.

7.12 RETRACTION DEVICE (Option)



It is strictly prohibited to use the retraction system before the bar feeder is anchored to the ground. Please read the safety instructions provided at the beginning of this manual before handling the following devices.



Before handling the retraction mechanism, make sure the interface cables between the spindle and the bar feeder have enough slack.

7.12.1 Description

When a lathe is equipped with a bar feeder, certain elements (motors, spindle reduction tubes, etc.) become inaccessible, and sometimes it is difficult, or even impossible, to proceed with their maintenance. Changing spindle liners on fixed headstock machines could also be a challenge. To facilitate these tasks, the bar feeder can be equipped with a retraction system, which allows the operator to move it away from the lathe. The rigidity of the system guarantees a perfect alignment when the bar feeder is in working position. Safety switches impede any handling as long as the bar feeder is not in operational position.

7.12.2 Operation

Conditions:

- Bar feeder in MANUAL or STOP mode.
- No bar between the bar feeder and the lathe
- Pusher inside the bar feeder
- The area around the bar feeder must be clear

Procedure:

1. Loosen the 8 lock bolts (A) on the two stands. 4 bolts on each side of the bar feeder.
2. Loosen and remove the 4 lock screws (B) behind the two stands.
3. Pull the bar feeder back by hand as the upper part of the bar feeder slides easily on the roller bearings. The safety switch SQ10 will engage (Refer to chapter 4.6)
4. After completing the maintenance operations, bring the bar feeder back in the forward working position, secure with lock screw (B) and tighten the side screws (A) (max. 75 Nm).

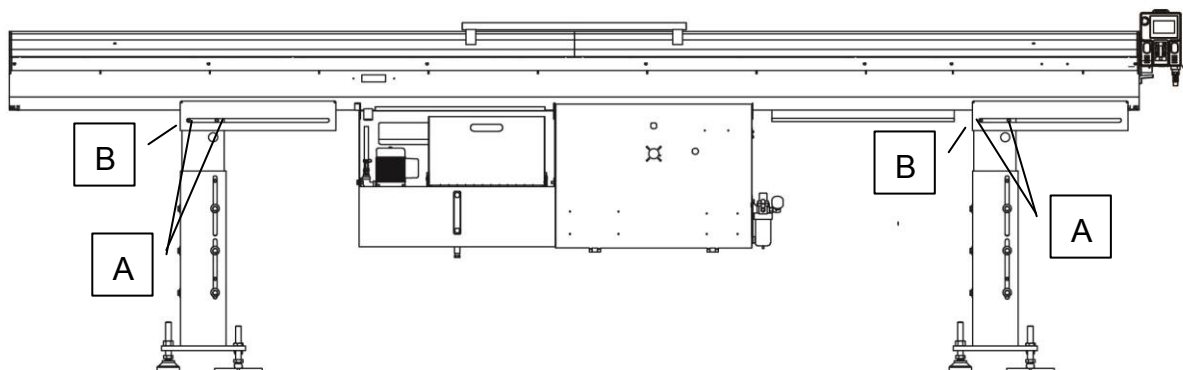

7.13 BAR PREPARATION

Bar preparation is the machining process which changes the shape of bar tip. It aims to get an improved insertion process during automatic process. The bar preparation must be selected according to the finger component the user chose. We recommend customers proceed bar preparation in advance for best machining performance.

● Chamfering

The very basic and necessary preparation. It's strongly recommended to apply this machining on each bar stock when a collet is selected.

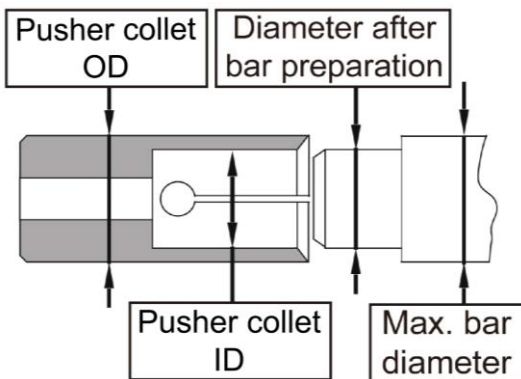
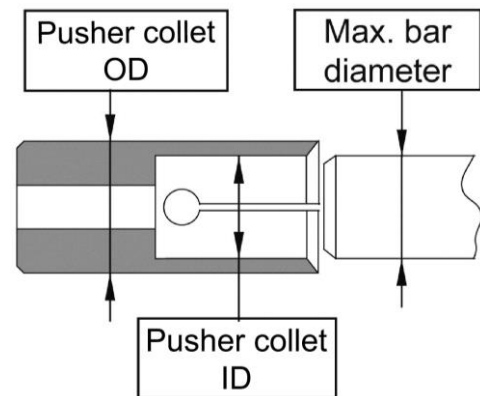

● Turning down

Due to strength concern, the maximum collet size within a guiding channel range is limited by its own wall thickness and therefore the maximum bar diameter is limited. To maximize the bar stock diameter, the user is recommended to turn down the bar tip as shown. The maximum bar stock diameter should be kept 1mm below the guiding channel.

Bar Preparation for pusher with cone head.

When the optional remnant disposal is selected to push the remnant through the chuck of the lathe by the newly loaded bar instead of being retracted in the bar feeder a cone must be installed on the pusher instead of a collet. For safety and performance reasons the bar end must be chamfered at a 60 degree angle.

Please contact our office for further details.

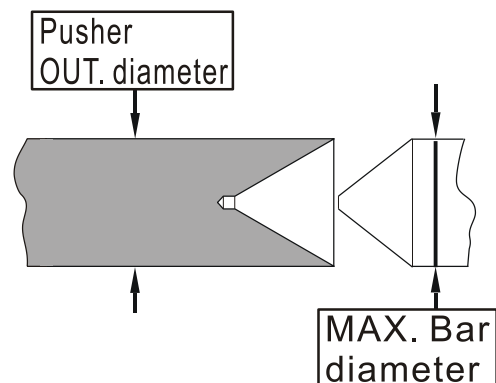

7.14 SPINDLE REDUCTION TUBES

The efficiency of the bar guiding while in rotation in the lathe is determined by the clearance between the spindle reduction tube and the rotating bar. The greater the clearance is, the more frequent the vibrations are.

Using reduction tubes helps to decrease this clearance. Guiding is thus improved, but, in addition, the insertion of the bar into the clamping device of the lathe is made much easier. The inside diameter of the reduction tubes should be chosen in terms of the diameter of the bar (diameter of the bar + 1 mm), but should always be larger than that of the diameter of the feeding pusher.

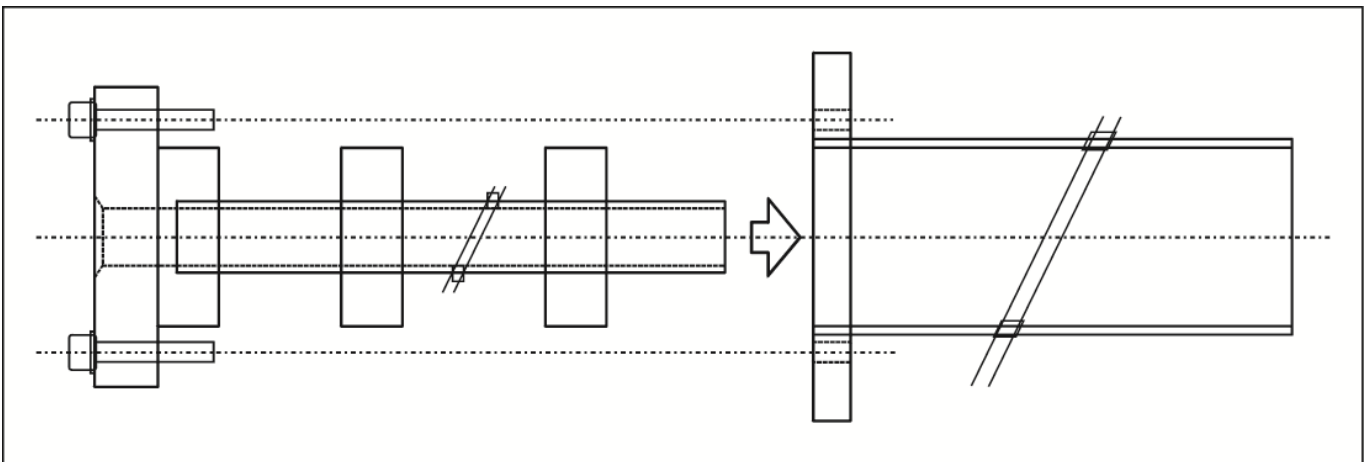

For inserting and removing the spindle reductions, move the bar feed system using the retraction device (Chapter 7/ Point 8) or slide the spindle liner through the bar feeder if design permits.



8 OPERATIONS



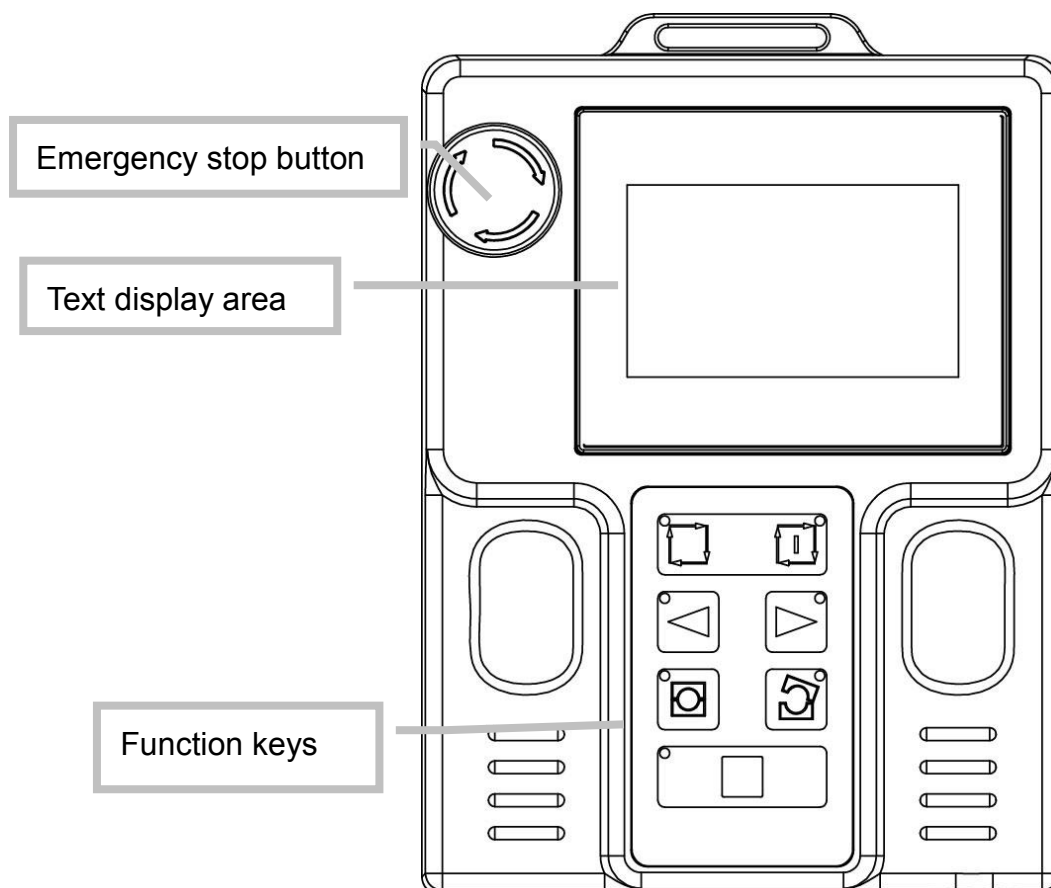





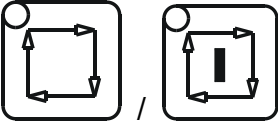

8.1 REMOTE CONTROL OPERATION

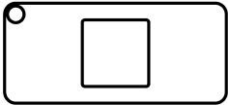

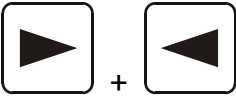
The remote control offers interface signal indicating LEDs and buttons for operating bar feeding system when it's in MANUAL mode.



8.1.1 Function keys

	<p>Emergency stop</p> <p>When a dangerous situation arises, pressing the emergency stop button immediately interrupts all functions of the bar feeder. The bar feeder will send alarm signal to the lathe and interrupt the lathe if interface is wired accordingly. Error message e01 will be shown on the HMI display.</p> <p>To cancel the alarm, release the button by rotating it clockwise</p> <p>Pressing the Manual key  will then reset the Emergency stop alarm-condition.</p>
---	---

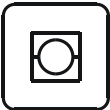
	<p>Auto ready/ Auto start</p> <p>To switch the bar feeder to AUTOMATIC mode, press "Auto ready"  (PLC X31)" then "Auto start"  (PLC X32)" key for 3 seconds, both LED in the keys are ON if all conditions are met. The bar feeder is now in AUTOMATIC mode.</p> <p>To switch to AUTOMATIC mode, one of the following conditions must be fulfilled :</p> <ul style="list-style-type: none"> • Main guiding channel closed. - OR - • Main guiding channel open and the pusher is at home position (SQ2 ON) and the bar measurement device is ready.
	<p>Manual</p> <p>This key offers two functions :</p> <ul style="list-style-type: none"> • To switch the bar feeder to MANUAL mode. When the bar feeder is in MANUAL mode, the LED in the key is ON and the user can operate the bar feeder by function keys. • To reset the bar feeder from an emergency stop.
	<p>Rightward</p> <p>Move pusher rightward. Only available when the bar feeder is in MANUAL mode.</p>
	<p>Slow Rightward</p> <p>Press  then press .</p> <p>Move the pusher rightward with 2% of the general speed. Only available when the bar feeder is in MANUAL mode.</p>
	<p>Leftward</p> <p>Move the pusher leftward. Only available when bar feeder is in MANUAL mode.</p>
	<p>Slow Leftward</p> <p>Press  then press .</p> <p>Move the pusher leftward with 2% of the general speed. Only available when the bar feeder is in MANUAL mode.</p>

	<p>Open Channel</p> <p>The key offers three functions :</p> <ol style="list-style-type: none"> 1. When pusher is at home position and bar feeder is in MANUAL mode, pressing this key will automatically start the following sequencing: <ul style="list-style-type: none"> • The long pusher moves forward to extraction position (behind the vise). • The vise closes to check remnant disposal. Then after the long pusher returns to its home position. • The guiding channel opens. 2. If the pusher exceeds the position “1ST FEED LOADING FLAG POSITION+ 150mm”, the channel will open when pressing this key. 3. Loading a bar from the magazine into the channel When the channel is open, pressing this key again the bar measuring device will set in the ready position (up).
	<p>Close Guiding Channel</p> <p>This key offers two functions :</p> <ol style="list-style-type: none"> 1. When the pusher is at a position shorter than the First Feed position and the bar feeder is in MANUAL mode, pressing this key will automatically start the following sequencing: <ul style="list-style-type: none"> • The loading flag moves forward to the First Feed position. • The short pusher returns to its home position. • The guiding channel closes and the long pusher advances for bar insertion. (If there's no bar, the bar feeder will not cycle an insertion.) 1. If the channel is opened by pressing  when the long pusher is at a position exceeding “1ST FEED LOADING FLAG POSITION+ 150mm” and the chuck of the lathe open the guiding channel will close when pressing .

8.1.2 Text display area

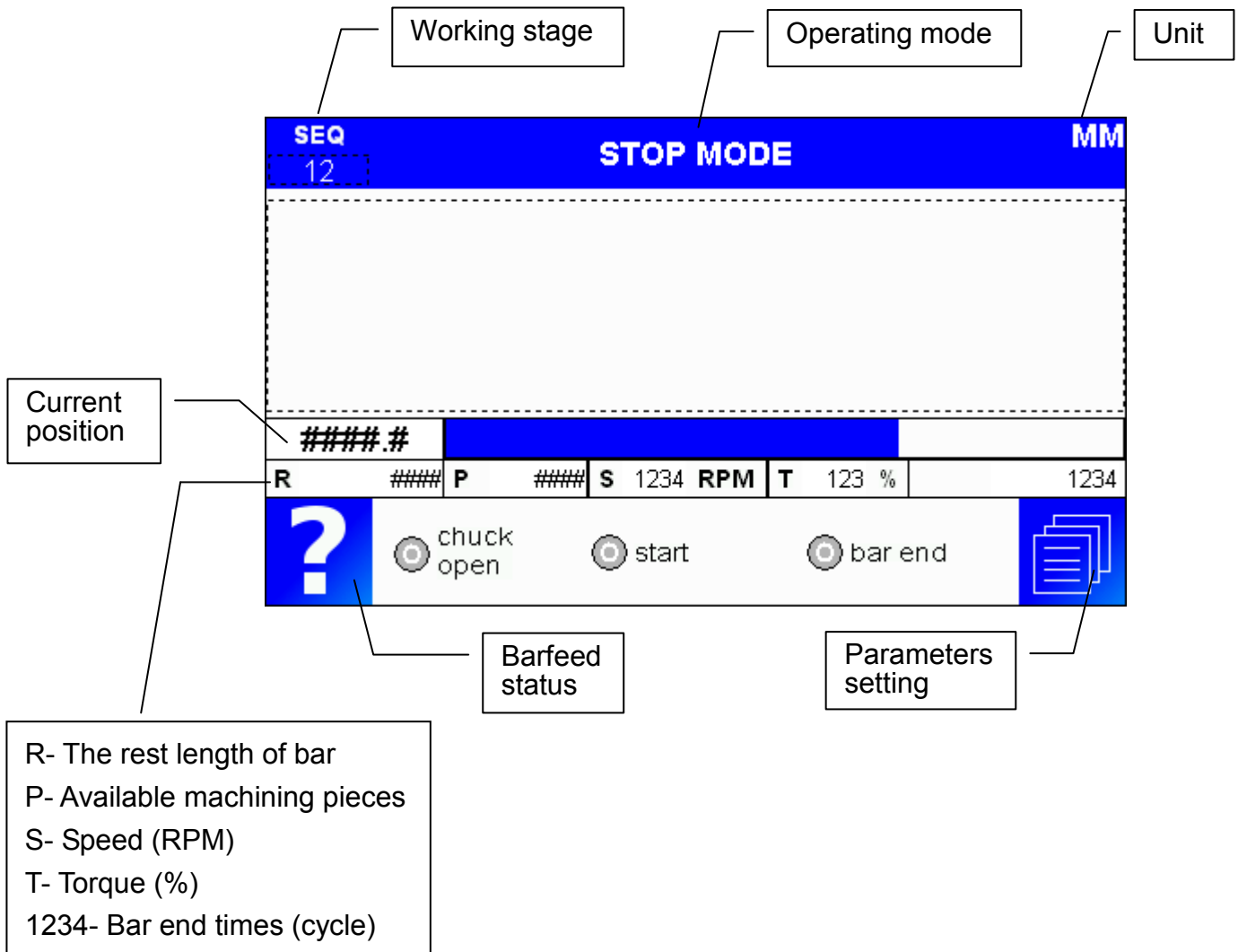

8.2 POWERING AND EMERGENCY STOP

8.2.1 Powering up

The main power is supplied by the interface cable. Before connecting the interface cable to the lathe, make sure the power supply meets the interface specifications.

Depending on the power supplied by the lathe a Transformer (optional) may be needed.

The power supplied to the bar feeder should be protected by a circuit-breaker (6A max) located in the lathe.

The servo motor of bar feeder is equipped with a built-in absolute encoder that continuously controls the position of the carrier. When the bar feeder is powered down or there is a power failure, this position is kept in the memory by the PLC.

When powering up, the pusher position value saved is immediately taken into account. The PLC reads signals from sensors and gives the operator allowable operations only.

Main disconnect switch QS1

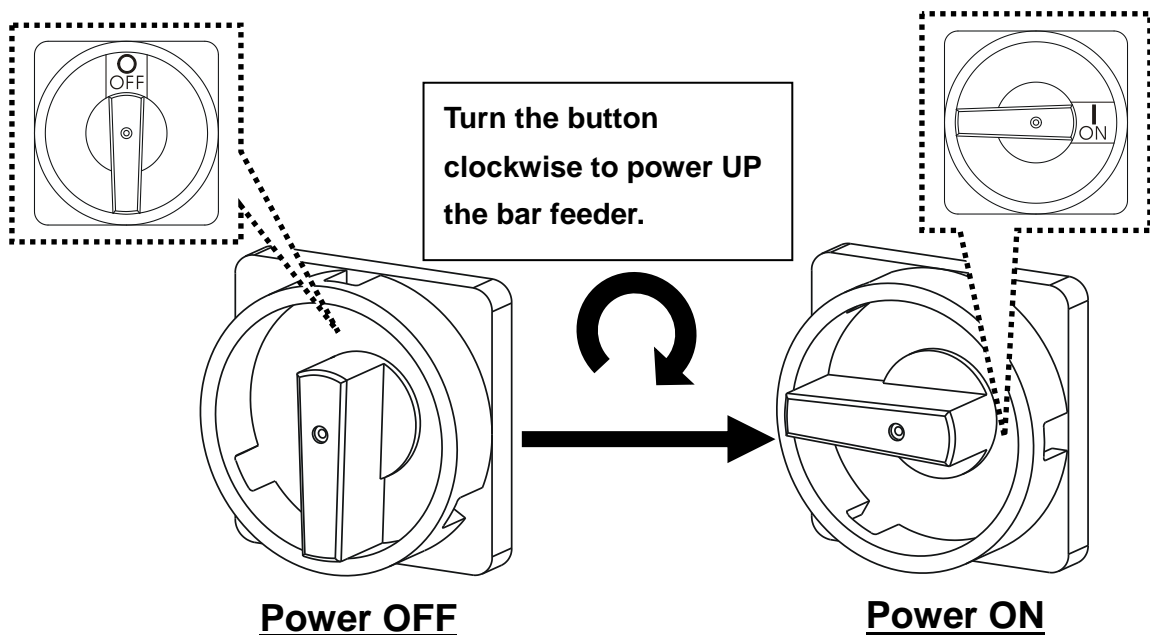

- Make sure it is turned OFF before opening the electrical cabinet.
- Do not move or change the pusher position by hand when bar feeder is powered OFF.

In case the pusher was accidentally moved before powering down move the pusher back to its home position. Turn the bar feeder OFF and power back up.

8.2.2 Emergency Stop button

When there is a dangerous situation arising. Pressing the emergency stop buttons to interrupt the bar feeder. The following procedures will be carried out.

1. The 3 phases 220V AC to servo amplifier is interrupted.
2. All the output signals of PLC are interrupted except Y20 (input signal of relay R1).
3. An alarm AL01 is arising at HMI.

When the emergency is removed, release the emergency stop button and press the manual key on remote control to restart the bar feeder.

Emergency stop button on the remote control

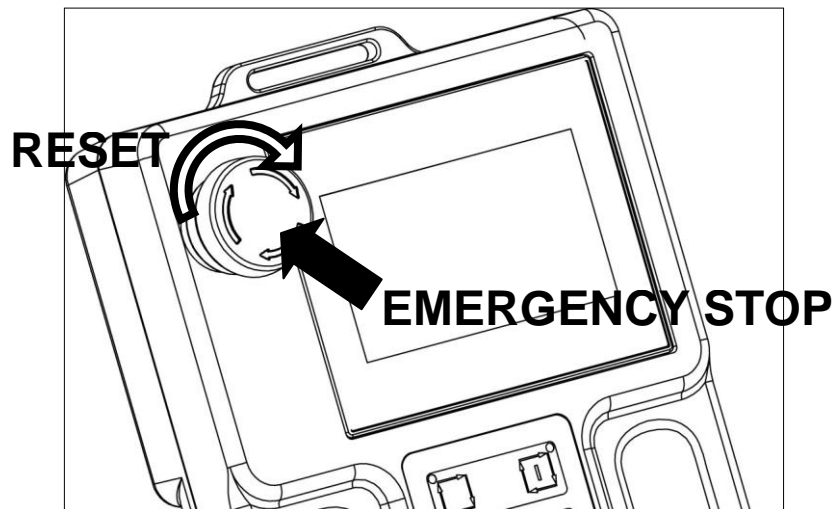

8.3 AUTOMATIC / MANUAL SEQUENCE

The bar feeder can be switched into AUTOMATIC mode from two starting conditions.









8.3.1 Start a new machining



Conditions must be fulfilled :

1. The lathe is not in **AUTOMATIC** mode.
2. The lathe chuck is open.
3. The lathe stopper must be positioned at the **TOP CUT** position

Before proceeding automatic sequence, make sure the bar feeder has been properly setup on pneumatics, hydraulics, electrics and mechanics according to bar stock dimension and machining conditions.

Step	Description	
1	Move the pusher to its home position and confirm the current pusher position is 0.	
2	Open the guiding channel by pressing 	
3	Press  to load a bar into channel. The bar measuring device will set ready (up).	
4	There are two methods to switch the bar feeder to auto mode: A: Start the lathe in AUTOMATIC sequence by accessing the sub-program and proceeding with the Top Cut cycle. Let the lathe start machining cycle by the program. B: In manual mode advance the bar to the Top Cut position. Start the lathe AUTOMATIC sequence from main program.	
	A	B
4	Press  and  to switch the bar feeder to AUTOMATIC mode, it will proceed step 5 and 6 automatically.	
5	The loading flag advances the bar to the First Feed position and then returns to its home position. The guiding channel is closed as well so insertion is completed.	Press  . The loading flag will feed the bar to the First Feed position then return to its home position. The guiding channel is closed as well so insertion is completed.
6	Position the bar to Top Cut position and send Start signal from the lathe.	Push forward by pressing  or  until the bar reaches the TOP CUT position.
7	Close lathe chuck, switch lathe to auto mode.	Close the chuck of lathe. Manually advance the bar to Top Cut.
8		Open the chuck of the lathe. Move the bar stopper of the lathe to the desired part length. Manually advance the bar until it touches the bar stopper in the lathe. Then close the chuck of the lathe and retract the bar stopper.
9	Press  and  to switch bar feeder	

	to AUTOMATIC mode. Then switch the lathe to AUTOMATIC mode.
--	---

**Method B:**

If parameter "Top cut positioning"=With turret, never switch the bar feeder into **AUTOMATIC** mode if the chuck of the lathe is open but no stopper in front of the chuck.



Do not switch lathe to **AUTO** mode before bar feeder is in **AUTO** mode.

8.3.2 Continue an interrupted machining



Conditions below must be fulfilled :

1. The lathe is not in **AUTOMATIC** mode.
2. The chuck of the lathe is open.
3. The bar stopper in lathe is positioned at part length position.
4. The bar feeder guiding channel is closed and pusher is not at home position.

Step	Description
1	Manually advance the pusher until the bar is against the bar stopper in the lathe.
2	Close the chuck of the lathe.
3	Press  and  to switch the bar feeder to AUTOMATIC mode. Then switch the lathe to AUTOMATIC mode.



1. If "Top cut positioning"=Without turret, never switch the bar feeder into **AUTOMATIC** mode if the chuck of the lathe is open with no bar stopper in front of the face of the chuck of the lathe to receive the front of the bar.
2. Never switch the lathe into **AUTOMATIC** mode before switching the bar feeder into **AUTOMATIC** mode.

8.3.3 Switch the bar feeder and lathe from Automatic to Manual mode

When the lathe finishes a machining cycle and the last part is cut-off with chuck closed, switch the bar feeder and lathe to manual mode as follows:

Step	Description
1	Switch the bar feeder to manual mode first.
2	Switch the lathe to manual mode and open the chuck of lathe last.



Never open the chuck of the lathe when the lathe is in manual mode and the bar feeder is in **AUTOMATIC** mode.

8.4 OPERATION PARAMETERS

The operation parameters are parameters that can be changed while the bar feeder is in AUTOMATIC mode. To obtain optimum performance, the operator is strongly recommended to read this chapter before making any changes to the parameters.

8.4.1 Accessing

After selecting the operation parameters by pressing F0, the following screen will be displayed

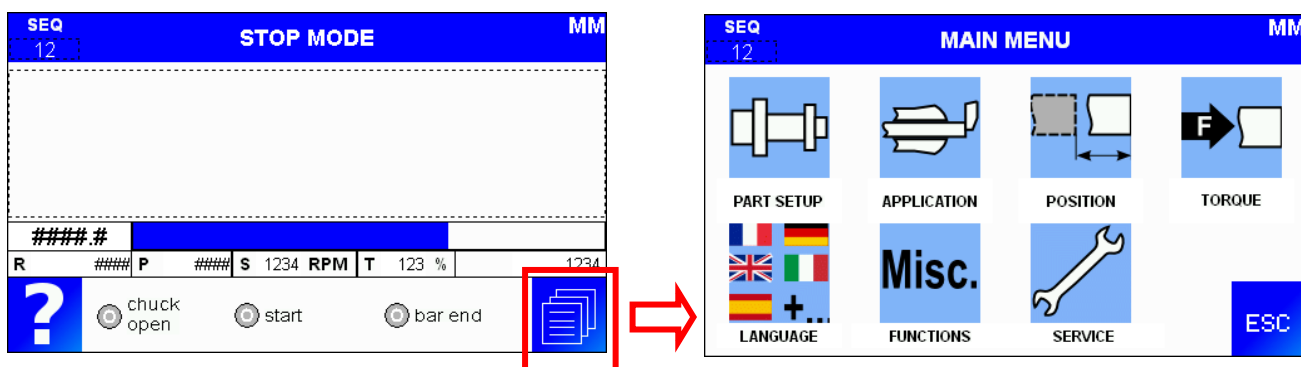

8.4.2 Quick preview

Designation	Description	Default Value				
PART SETUP						
Diameter & length	Bar diameter	Subject to actual use				
	Part length	100mm				
Guiding element	Guiding element	Subject to actual use				
Number of clamping device openings	Collect openings	1 times				
Part setup	Too short	0				
	Too long-collet closed	510mm				
	Too long- collet open	510mm				
APPLICATION						
Feeding type		Turret parked in position				
Application	M-code for part feed out	NO				
	Deceleration distance	20mm				
	Bar loading rear limiter position	0				
	Loading screw 2 turns for bar	7.0				
POSITION						
End of bar		2.0M	2.5M	3.0M	12'	4.0M
		2350	2850	3350	4050	4350
Top cut	Top cut position	200mm				
Auxiliary end of bar	Auxiliary end of bar position	1000mm	1500mm	2000mm	2700mm	3000mm
External stabilizer (option)	External stabilizer opening position	0	0	0	0	0
Hydraulic pump OFF	Hydraulic pump OFF at pusher position	1300mm	1800mm	2300mm	3000mm	3300mm
Position	Insertion travel distance	43mm				
	Extraction travel distance	45mm				
TORQUE						
Pusher torque rate	During feeding	Depend on "PART SETUP"				
	With clamping device closed (For fixed headstock machine)					
	To compensate the pusher friction (For sliding headstock machine)					
	Against the cut-off tool (For sliding headstock machine)					
LANGUAGE						
Language	Subject to actual use					
Unit of measure	Subject to actual use					
Functions						
Dry run						

8.4.3 Description

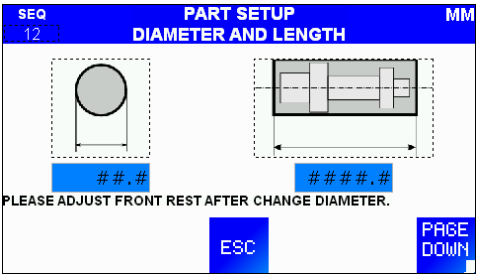
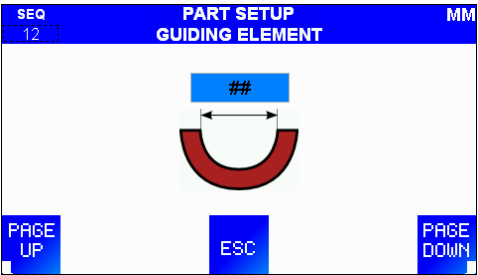
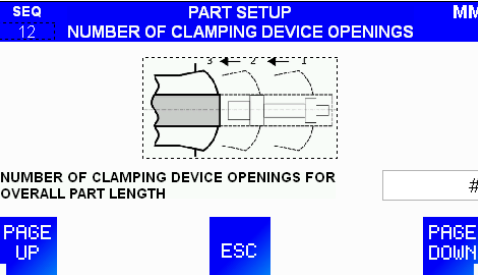
PART SETUP	
DIAMETER & LENGTH	<i>This parameter should be modified if bar stock dimension changed.</i>
<p>BAR DIAMETER This parameter sets the basic pushing force. Enter the bar stock diameter currently loaded inside the channel.</p> <p>PART LENGTH Overall feeding length needed for making a part. Part length plus cut off tool width.</p> <p>This value is for calculation of BAR END position and timing of sending CYCLE START signal. The bar feeder will not stop at this distance during feeding. The lathe must place a stopper inside the lathe for positioning.</p> <p><i>Example: If the part is 100mm and the cut off tool width is 3mm. The value entered here is 100+3=103.</i></p>	
GUIDING ELEMENT	<i>This parameter should be modified if the guide channel size is changed.</i>
<p>GUIDING ELEMENT SIZE The diameter of the guiding elements is always proposed for change after the pusher changeover cycle.</p>	
NUMBER OF CLAMPING DEVICE OPENINGS	
<p>Number of lathe clamping openings during the machining of one part. Used to prevent undesired part feed out during clamping opening.</p>	

PART SETUP

The maximum/minimum acceptable feeding length for machining a part.

TOO SHORT

The minimum allowable bar feeding distance.

TOO LONG –COLLET CLOSED

The maximum allowable feeding distance when chuck is closed.

TOO LONG –COLLET OPEN

The maximum allowable bar feeding distance when chuck is open.

The setup varies depend on lathe type.

Lathe type	Fixed type	Swiss type
Too short	Part length -15mm	
Too long collet closed	Less than part length	(Max spindle movement of machining a part)+15mm
Too long collet open	Part length +15mm	Less than part length



PART SETUP

LOADING SCREW 2 TURNS FOR 1 BAR

1. When bar diameter is smaller than the setting value, the screw will load 1 bar by 1 turn.
2. When bar diameter is larger than or equal to the setting value, the screw will load 1 bar by 2 turns.
3. When this setting value is equal to zero, the screw will only load 1 bar by 1 turn.

(By default for USA, this value should always be set to 7.0)



APPLICATION**FEEDING TYPE**

Defines if the lathe turret waits in position or follows the barstock displacement during feeding operation.

TURRET PARKED IN POSITION

Turret moves forward for a part length and waits till barstock touches it.

TURRET MOVES TO POSITION

Turret moves backward to touch the front tip of barstock and follows it to the part length position.

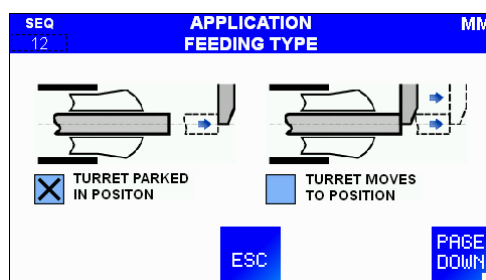
**APPLICATION****M-CODE FOR PART FEED OUT**

During production time, the lathe issues an M-code signal (A4). The bar feed will push the bar into position and emit a signal over the R2 relay to reset the M-code and the lathe will then be able to continue working.

DECELERATION DISTANCE FOR FEED OUT

Distance in which the pusher has to slow down before the stopper.

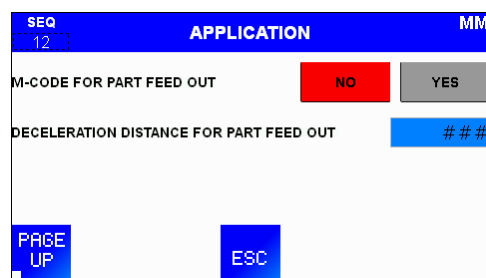
**APPLICATION**

It defines the position of first feeder when a new bar is loaded. This setup can shorten the time of FIRST FEED. Move first feeder forward to loading flag position manually then insert the value according to the current pusher position.

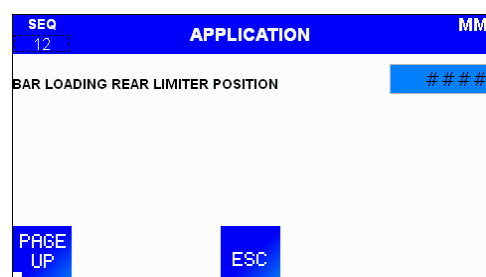

POSITION

END OF BAR

This parameter should be modified if the bar feeder is re-installed or moved.

END OF BAR

Limit position set to prevent the pusher to reach inside the chuck of the lathe. It is set at about 10 mm behind the chuck jaws of collet pads of the lathe. In automatic cycle a new bar will be loaded in the guiding channel.

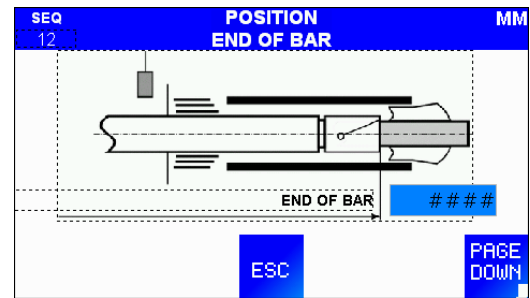

TOP CUT

This parameter should be modified if the bar feeder is re-installed or moved.

- Position of the newly loaded bar outside the front of the chuck of the lathe. The term Top Cut is a face off or cut off operation before starting a new production part after a new bar is loaded.
- This position is measured by the sensor SQ1 (bar measuring device.). The value is independent from bar length. It will not change unless the bar feeder is moved.
- During automatic cycle, the bar measuring device flag is activated while the new bar is loading.

TOP CUT REFERENCE (read only)

The position measured automatically from bar measuring device (SQ1) for TOP CUT value reference.

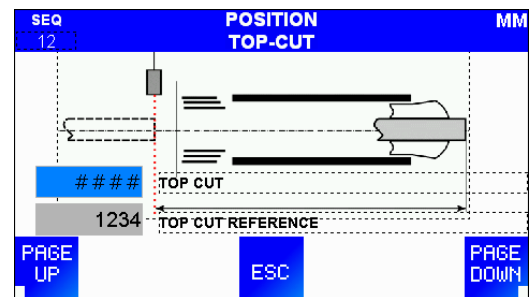

AUXILIARY END OF BAR

Depending on the lathe and its options, the auxiliary end of bar may be used in several ways, for example for the opening of an external rest.

The procedure is the same as this for the end of bar setting.

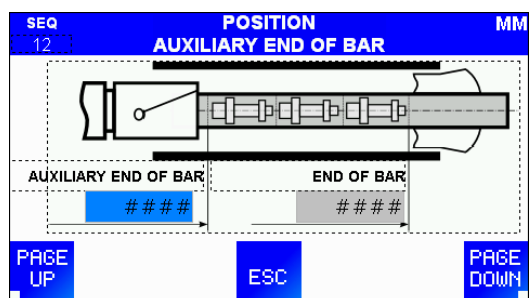

EXTERNAL STABILIZER (OPTION)	
<p>EXTERNAL STABILIZER (second anti-vibration) Define the pusher position where the external stabilizer opens.</p>	

HYDRAULIC PUMP OFF	
<p>HYDRAULIC PUMP OFF AT PUSHER POSITION When the pusher reaches this position, the oil bath is not necessary anymore, and the hydraulic pump is deactivated.</p>	

POSITION	
<p>INSERTION TRAVEL DISTANCE Specifies the stroke of the pusher for the insertion of the bar into the pusher collet.</p>	
<p>EXTRACTION TRAVEL DISTANCE Specifies the stroke of the pusher for the extraction of the bar from the pusher collet.</p>	

TORQUE

PUSHER TORQUE RATE

Torque values as described.

DURING FEEDING

Part setup will influence the torque of bar feeding including during the FIRST FEED, feeding into lathe, manual forward and feed on fixed headstock type lathe with chuck opened.

WITH CLAMPING DEVICE CLOSED (For fixed headstock machine)

Torque applied during machining operations.

Part setup will influence the torque when the chuck of the lathe is closed. User can also use this parameter to adjust the torque.

TO COMPENSATE THE PUSHER FRICTION (For sliding headstock machine)

The torque applied during machining operations.

AGAINST THE CUT-OFF TOOL (For sliding headstock machine)

This setup defines the torque applied when the bar stock pushes against the tool.

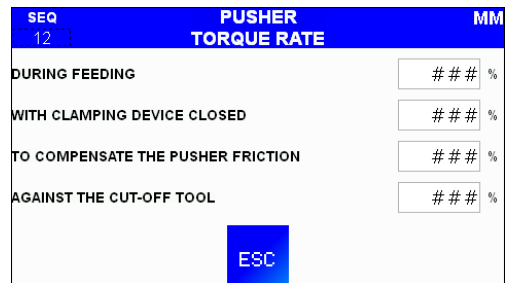

Language

LANGUAGE

Allows the user to choose the barfeed HMI language.

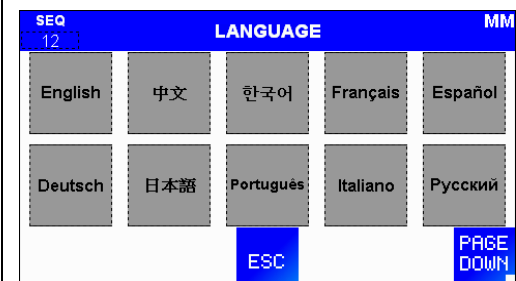

UNIT OF MEASURE

Allows choosing the unit of measure.

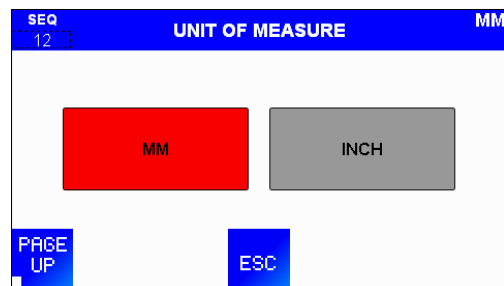
**Functions****FUNCTIONS**

Dry run and external stabilizer setup functions are available on this screen.

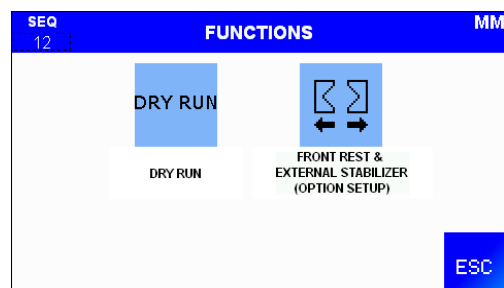
**DRY RUN**

This state allow the lathe to run without the bar feeder. Conditions: Bar feeder in manual or stop mode, channel open (SQ3 ON) and pusher at home position (SQ2 ON) and bar measuring device ready (SQ1 ON)”; Press “DRY RUN”, the bar feeder will switch to DRY RUN mode. Interface output signal (R4) will automatically turn on and interface signals from the lathe will be ignored.

Press “STOP” to exit.



8.5 SERVICE PARAMETERS

Service parameters must only be modified by trained technicians or personnel authorized by LNS representative. Incorrect setup might cause safety hazards and/or unexpected malfunction or damage on either bar feeder or lathe. Accessing these parameters is password protected. Please contact LNS or one of its representatives for assistance.

8.5.1 Accessing

After selecting the service parameters by pressing F1 as shown, the following screen will be displayed:

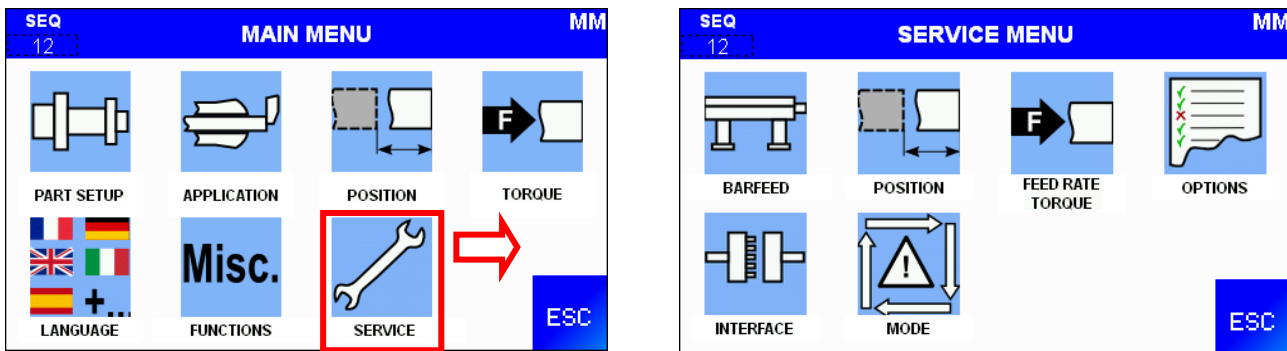

8.5.2 Quick preview

Parameter designation	Description	Default value					
BARFEED							
Barfeed length	2.0M	Subject to actual use					
	3M						
	12'						
	4M						
Barfeed location	Left/ Right	Left					
1 st feed loading flag position	Standard pusher	2M	2.5M	3M	12'	4M	
	Extended pusher (STD USA)	1101mm					
Pusher type	With collet/ With cone	1348mm					
Pusher type	With collet/ With cone	Subject to actual use					
Loading cycle enable while clamping device	Open/ Closed	Open					
Automatic halt push forward at end of bar	No/ Yes	Yes					
Bar check after extraction (manual mode)	Activate check/ Deactivate check	Activate					
Close front rest & external stabilizer on the pusher when clamping device is closed	No/ Yes	No					
Barfeeder auto safety	No/ Yes	No					
POSITION							
Pusher retracts dist. For spindle inching		50mm					
Cover setup	Standard pusher		2M	2.5M	3M	12'	4M
		Active cover 1	1000				
		Active cover 2	1550				
		Active cover 3	0	1750	1750	1950	1950
		Active cover 4	0	0	2050	2350	2350
	Active cover 5	0	0	0	2650	2650	
	Extended pusher (STD USA)	Active cover 1	1250				
		Active cover 2	1450	1800			
		Active cover 3	0	2400	2400	2400	2500
		Active cover 4	0	0	3000	3000	3100
		Active cover 5	0	0	0	2900	3700
FEED RATE/ TORQUE							
Torque rate	During insertion	250%					
	During extraction	250%					
Feed rate	During part feed out	350RPM					
	During barstock measuring	300RPM					
	Without barstock	940RPM					
	Manual forward	400RPM					
	Manual reverse	400RPM					
	With clamping closed (fixed headstock)	45RPM					
Torque rate	Torque setting- Asia/ Western	Subject to actual use					
OPTIONS							
Headstock synchronization device	No/ Yes	Subject to actual use					
External stabilizer operation	Keep closed/ With chuck open/close	Keep closed					

Booster type	Servo/ Mechanical	Servo
Top cut positioning	With turret/ Without turret	Without turret
Bar insertion check	No/ Yes	No

SERVICE PARAMETERS

(Password protected, only for trained technician)

SERVICE MENU	
Main screen	

BARFEED

BARFEED SETUP	
Defines the Bar feeder length and position is Left/ Right of machine.	

BARFEED SETUP	
<p>1ST FEED LOADING FLAG POSITION</p> <ul style="list-style-type: none"> The bar stock first movement right after it's loaded into the bar feeder. First Feed by Loading Flag. This movement is called FIRST FEED. It is used to locate the bar rear tip at the insertion position. The FIRST FEED must be correctly set so that the gap between the bar rear tip and collet of the pusher is within 5mm. 	
<p>PUSHER TYPE</p> <p>Allow to choose pusher with collet or pusher with cone.</p>	
<p>LOADING CYCLE ENABLE WHILE CLAMPING DEVICE</p> <p>Defines at End of Bar the loading cycle will initiate when receiving the chuck signal open or close.</p>	

<p>BARFEED SETUP</p>	
<p><u>AUTOMATIC HALT PUSHER FORWARD AT EOB</u> If this parameter is set to YES, the bar feeder don't push forward at end of bar (Only with Swiss type lathe).</p> <p><u>BAR CHECK AFTER EXTRACTION (MANUAL MODE)</u> Defines if cancel detection of bar extraction in manual mode.</p> <p><u>CLOSE FRONT REST & EXTERNAL STABILIZER ON THE PUSHER WHEN CLAMPING DEVICE IS CLOSED</u> Defines if the front rest and external stabilizer clamp while the pusher is passing through during automatic mode.</p>	

<p>BARFEED SETUP</p>	
<p><u>BARFEEDER AUTO SAFETY</u> This parameter checks if the bar feeder is already in AUTOMATIC mode when the chuck signal is turned ON/OFF for 3 cycles without receiving the Auto signal from the lathe.</p>	

POSITION

<p>POSITION</p>	
<p>Defines the retraction distance of the pusher for spindle inching during loading of profiled bars.</p>	

POSITION	
Define each open position of the sectional covers. Set the value according to the pusher position for the pusher flag to pass through the channel.	
<u>ACTIVE COVER 1</u>	
The pusher position where the first channel must open when the pusher passes it.	
<u>ACTIVE COVER 2</u>	
The pusher position where the second channel must open when the pusher passes it.	
<u>ACTIVE COVER 3</u>	
The pusher position where the third channel must open when the pusher passes it.	
<u>ACTIVE COVER 4</u>	
The pusher position where the fourth channel must open when the pusher passes it	

	<table border="1"> <tr> <td style="width: 15%;">SEQ</td> <td style="width: 65%;">SERVICE MENU</td> <td style="width: 20%;">MM</td> </tr> <tr> <td>12</td> <td>BARFEED SETUP</td> <td></td> </tr> <tr> <td>ACTIVE COVER 1</td> <td></td> <td>####</td> </tr> <tr> <td>ACTIVE COVER 2</td> <td></td> <td>####</td> </tr> <tr> <td>ACTIVE COVER 3</td> <td></td> <td>####</td> </tr> <tr> <td>ACTIVE COVER 4</td> <td></td> <td>####</td> </tr> <tr> <td>PAGE UP</td> <td>ESC</td> <td>PAGE DOWN</td> </tr> </table>	SEQ	SERVICE MENU	MM	12	BARFEED SETUP		ACTIVE COVER 1		####	ACTIVE COVER 2		####	ACTIVE COVER 3		####	ACTIVE COVER 4		####	PAGE UP	ESC	PAGE DOWN
SEQ	SERVICE MENU	MM																				
12	BARFEED SETUP																					
ACTIVE COVER 1		####																				
ACTIVE COVER 2		####																				
ACTIVE COVER 3		####																				
ACTIVE COVER 4		####																				
PAGE UP	ESC	PAGE DOWN																				

POSITION	
<u>ACTIVE COVER 5</u>	
The pusher position where the fifth channel must open when the pusher passes it	

	<table border="1"> <tr> <td style="width: 15%;">SEQ</td> <td style="width: 65%;">SERVICE MENU</td> <td style="width: 20%;">MM</td> </tr> <tr> <td>12</td> <td>BARFEED SETUP</td> <td></td> </tr> <tr> <td>ACTIVE COVER 5</td> <td></td> <td>####</td> </tr> <tr> <td>PAGE UP</td> <td>ESC</td> <td></td> </tr> </table>	SEQ	SERVICE MENU	MM	12	BARFEED SETUP		ACTIVE COVER 5		####	PAGE UP	ESC	
SEQ	SERVICE MENU	MM											
12	BARFEED SETUP												
ACTIVE COVER 5		####											
PAGE UP	ESC												

FEED RATE/ TORQUE

TORQUE RATE	
Sets the torque of servo motor to define the pushing force for bar insertion and extraction.	
<u>DURING INSERTION</u>	
The default value of torque: 250%	
<u>DURING EXTRACTION</u>	
The default value of torque: 250%	

	<table border="1"> <tr> <td style="width: 15%;">SEQ</td> <td style="width: 65%;">SERVICE MENU</td> <td style="width: 20%;">MM</td> </tr> <tr> <td>12</td> <td>TORQUE RATE</td> <td></td> </tr> <tr> <td>DURING INSERTION</td> <td></td> <td>### %</td> </tr> <tr> <td>DURING EXTRACTION</td> <td></td> <td>### %</td> </tr> <tr> <td></td> <td>ESC</td> <td>PAGE DOWN</td> </tr> </table>	SEQ	SERVICE MENU	MM	12	TORQUE RATE		DURING INSERTION		### %	DURING EXTRACTION		### %		ESC	PAGE DOWN
SEQ	SERVICE MENU	MM														
12	TORQUE RATE															
DURING INSERTION		### %														
DURING EXTRACTION		### %														
	ESC	PAGE DOWN														

FEED RATE	
Defines the feed rate of the pusher movement during these three situations.	

FEED RATE	
Defines the feed rate of the pusher movement during these three situations.	

TORQUE RATE	
Allow to choose torque setting with Asia or Western style.	

OPTIONS

OPTIONS SETUP	
HEADSTOCK SYNCHRONIZATION DEVICE	
Defines if using the headstock synchronization device.	
EXTERNAL STABILIZER OPERATION	
Defines the action of optional external stabilizer before the pusher reaches the position set on second anti-vibration.	
<ul style="list-style-type: none"> - Keep closed - Follow the chuck moving open and close 	
BOOSTER TYPE	

Allow to choose booster type for SERVO or MECHANICAL.

OPTIONS SETUP

TOP CUT POSITIONING

Defines Top Cut positioning with or without turret help.

BAR INSERTION CHECK

When bar insertion is completed the pusher will move back and forth. During this cycle the vise with close to verify if the bar is inserted.

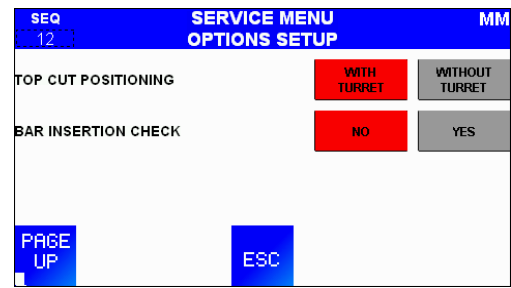

INTERFACE

INTERFACE

Shows several interface parameter status. Please refer to the INTERFACE PARAMETER NUMBERS description as following or click on the parameter number on the touch screen to show more information.

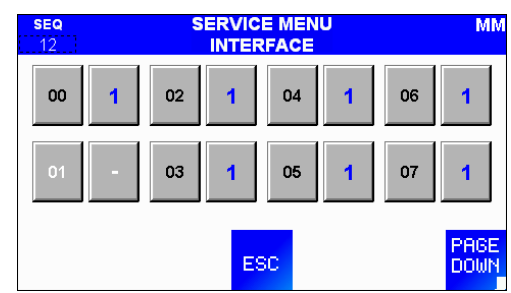

00- Clamping signal (A1) logic setup

- 1 Clamping signal on HMI (A1) lit, the lathe chuck is closed.
- 2 Clamping signal on HMI (A1) lit, the lathe chuck is open.

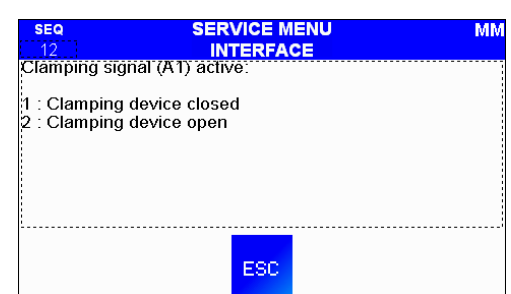

02- Pusher motion setup

Defines whether the pusher motion is allowed with the chuck of the lathe closed during bar feeder in manual mode.

- 1 When the lathe chuck is closed, no manual motion of the pusher is allowed.
- 2 When the lathe chuck is closed, manual motion of the pusher is allowed.

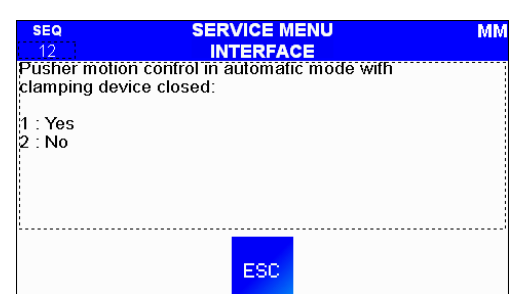

03- Loading interrupt if A2 or A4 signal de-energizes

Defines during a bar change cycle, the condition for pushing the bar when the chuck of the lathe opens.

- Neither A2 nor A4 signal is checked. During a bar change cycle, when the chuck of the lathe opens, the pusher will advance the bar to Top Cut position.
- Either A2 or A4 signal is checked. During a bar change cycle, either one of the signals is required for pushing bar stock to Top Cut position when the chuck of the lathe opens.

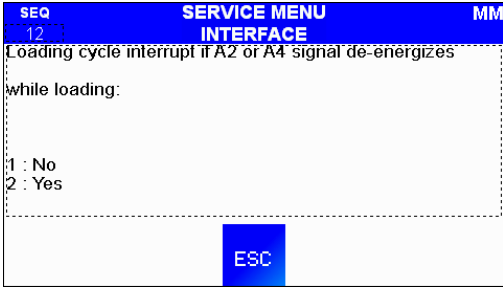

04- (A3) Priority load command from lathe (Refer to INTERFACE05 for related setup)

Defines if A3 signal initiates the bar change cycle.

- The bar change cycle initiates when the chuck of the lathe opens at end of bar.
- The bar change cycle initiates depending on INTERFACE05 setup (End of Bar).

* Refer to the timing chart <1> on 8.6.2.1

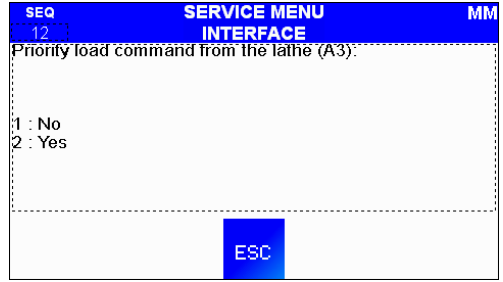

05- EOB signal required by the lathe (Refer to INTERFACE04 for related setup)

Defines when the new bar change cycle is initiated by A3 signal.

- Bar change cycle initiates when receiving A3 signal after the End of Bar signal arises.
- Bar change cycle initiates at any time when A3 signal is received.

* Refer to the timing chart <1> on 8.6.2.1

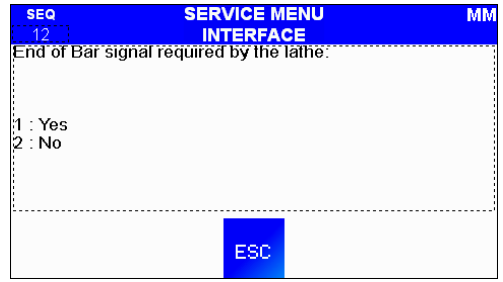

06- Loading cycle enable

Defines when the new bar change cycle is enabled.
(This applied only if INTERFACE04=1)

- 1 At End of Bar the loading cycle will initiate when receiving the chuck signal open.
- 2 At End of Bar the loading cycle will initiate after receiving the chuck close signal (pusher with cone)

SEQ	SERVICE MENU	MM
12	INTERFACE	
Loading cycle enable:		
1 : While clamping device open		
2 : While clamping device closed		
ESC		

07- Lathe type setup

- 1 Fixed headstock lathe
- 2 Sliding headstock lathe
- 3 Camshaft lathe

SEQ	SERVICE MENU	MM
12	INTERFACE	
Machine type:		
1 : Fixed headstock		
2 : Sliding headstock		
3 : Camshaft		
ESC		

09- Push signal from the lathe (Refer to INTERFACE24 for related setup)

- 1 Chuck signal A1 and AUTO signal A2 enables the pusher to advance the bar stock.
- 2 Chuck signal A1 and M-Code Push A4 enables the pusher to advance the bar stock.

* Refer to the timing chart <2> on 8.6.2.1

SEQ	SERVICE MENU	MM
12	INTERFACE	
Push signal from the lathe:		
1 : (A2) Lathe in automatic cycle		
2 : (A4) M-Code advance		
ESC		

10- AUTO signal (A2) setup

When the lathe is switched to automatic mode, AUTO signal A2 turns ON. This parameter defines the type of A2 signal-

- 4 A2 signal is a latched signal.
- 2 A2 signal is a pulsed signal.

SEQ	SERVICE MENU	MM
12	INTERFACE	
PLC input A2 is:		
1 : Latched		
2 : Pulsed		
ESC		

11- PUSH signal (A4) setup

Defines the type of the A4 signal for bar feeding.

- 1 A4 signal is a latched signal. The pusher will advance the bar stock while receiving A4 signal.
- 2 A4 signal is a pulsed signal. The pusher will advance the bar stock once A4 signal is sent

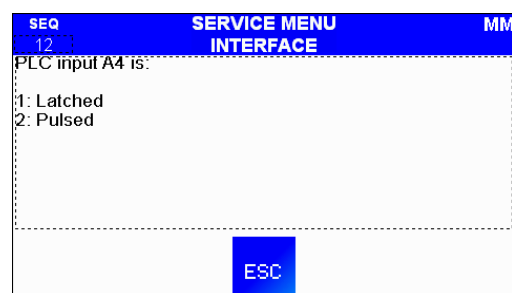

12- Pushing force setup with sliding headstock

Defines the pushing force for sliding lathe with chuck opened.

- 1 When the lathe chuck opens, the pushing force is according to "PUSHER TORQUE RATE": TO COMPENSATE THE PUSHER FRICTION.
- 2 When the lathe chuck opens, the pushing force is according to "PUSHER TORQUE RATE": AGAINST THE CUT-OFF TOOL.

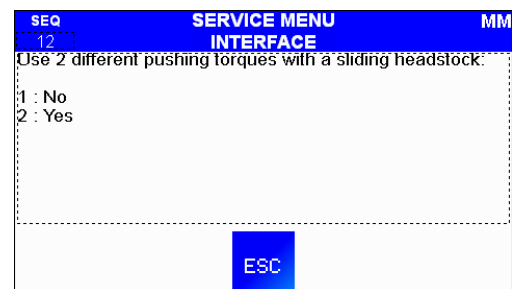

13- R2 while in production cycle (Refer to INTERFACE14, 15, 16 for related setup)

Defines if R2 signal is On or Off during production cycle

- 1 R2 signal output according to INTERFACE14, 15, 16 and 34 setup.
- 2 R2 signal is ON after the newly loaded bar reaches the Top Cut position and turns OFF when bar feeder starts a new loading cycle.
This output indicates the bar feeder is in working mode.

* Refer to the timing chart <3> on 8.6.2.1

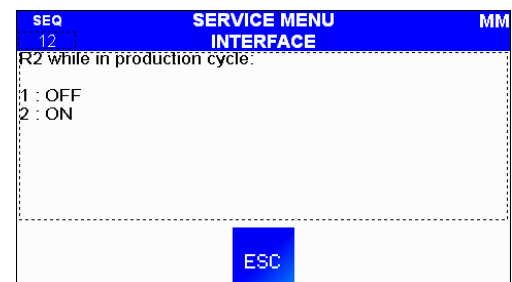

14 R2 during End of Bar (Refer to INTERFACE13, 15, 16 for related setup)

Defines the condition of R2 signal at End of Bar.

- 1 R2 signal will be OFF during End of Bar condition.
- 2 R2 signal will be ON during End of Bar condition.

* Refer to the timing chart <3> on 8.6.2.1

SEQ	SERVICE MENU	MM
12	INTERFACE	
R2 during End of Bar:		
1 : OFF		
2 : ON		
ESC		

15 R2 ON at top cut position (Refer to INTERFACE13, 14, 16 for related setup)

Defines how long R2 signal remains On from the time the new bar stock reached the Top Cut position.

- 1 R2 signal remains ON until the chuck of the lathe closes.
- 2 R2 signal is pulsed for 2 seconds.

* Refer to the timing chart <3> on 8.6.2.1

SEQ	SERVICE MENU	MM
12	INTERFACE	
R2 on at Top-Cut position:		
1 : Until the clamping device is closed		
2 : Pulsed for 2 seconds		
ESC		

16 R2 to confirm (Refer to INTERFACE13, 14, 15 for related setup)

Defines R2 signal functionality.

- 1 R2 signal turns ON to confirm the newly loaded bar reaches Top Cut position.
- 2 R2 signal turns ON to confirm the newly loaded bar reaches the Top Cut position and also to confirm part feedout when M-code is connected.

* Refer to the timing chart <3> on 8.6.2.1

SEQ	SERVICE MENU	MM
12	INTERFACE	
R2 signal to confirm:		
1 : Top-Cut only		
2 : Top-Cut and Part Feed		
ESC		

17 R3 signal latches at End of Bar

(Refer to INTERFACE18, 19, 20, 31, 32, 33 for related setup)

Defines the type of R3 signal output.

- 1 R3 signal turns ON when the pusher reaches the End of Bar position and remains ON. It turns OFF according to INTERFACE18, 19, 20 or 33 setup.
- 2 R3 signal turns ON only while the pusher is in the End Of Bar position.

SEQ	SERVICE MENU	MM
12	INTERFACE	
R3 signal latches at End of Bar:		
1 : Yes		
2 : No		
ESC		

* Refer to the timing chart <4> on 8.6.2.1

18 R3 turns on at EOB and turns off
(Refer to INTERFACE17, 19, 20, 31, 32, 33 for related setup)

Defines when R3 signal turns OFF.

- 1 R3 signal turns OFF when A3 signal is activated and the pusher retracts back to home position.
- 2 R3 signal turns OFF when the last machining is finished and the lathe chuck opens.

* Refer to the timing chart <4> on 8.6.2.1

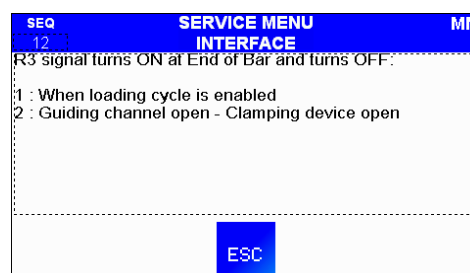

19 R3 turns ON at EOB and turns OFF
(Refer to INTERFACE17, 18, 20, 31, 32, 33 for related setup)

Defines when R3 signal turns OFF.

- 1 R3 signal turns OFF when A3 signal is activated and the pusher retracts back to home position.
- 2 R3 signal turns OFF when the new bar reaches Top Cut position

* Refer to the timing chart <4> on 8.6.2.1

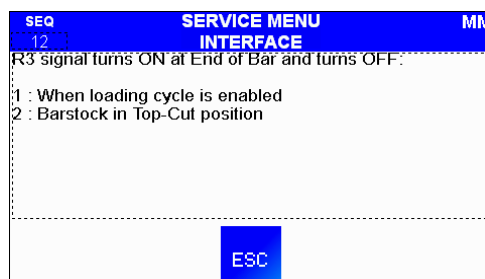

20 R3 pulses for 2 sec. at End of Bar
(Refer to INTERFACE17, 18, 19, 31, 32, 33 for related setup)

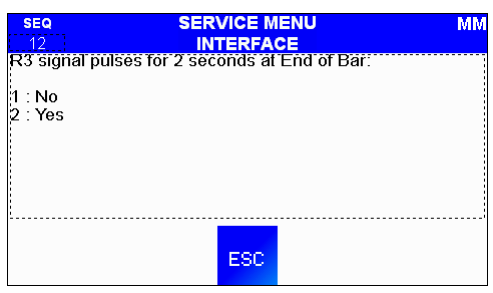
<p>Defines if R3 signal pulses for 2 seconds or not.</p> <ol style="list-style-type: none"> R3 signal is not a pulse signal. Refer to INTERFACE18, 19 or 33 for related setup on to turning OFF. R3 signal is a 2 seconds pulses signal. <p>* Refer to the timing chart <4> on 8.6.2.1</p>	
--	--

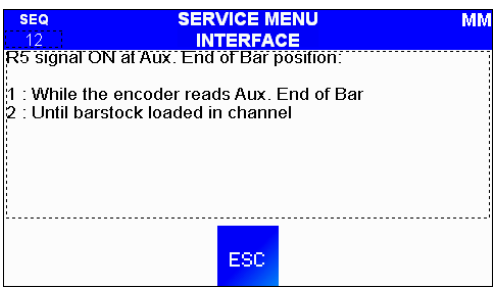
<p>21 R5 ON at Aux. EOB position (Refer to INTERFACE43 for related setup)</p>	
<p>When the pusher arrives at “AUXILIARY END OF BAR” position, R5 signal turns ON. This parameter defines the output type of R5 signal.</p> <ol style="list-style-type: none"> R5 signal turns ON when pusher passes the Aux. EOB position. R5 remains ON when the pusher exceeds the Aux. EOB position until the bar feeder loads a new bar stock. <p>This parameter is only applied if INTERFACE43 set 1.</p>	

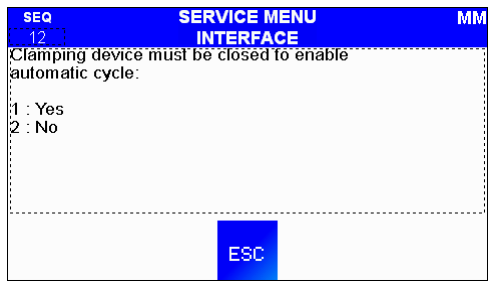
<p>22 Clamping device closed to start AUTO</p>	
<p>Defines if the chuck of the lathe must be closed at Auto Start of the bar feeder.</p> <ol style="list-style-type: none"> Safety setup. The chuck of the lathe must be closed before switching to automatic mode. The chuck condition of the lathe does not matter to switch the bar feeder to automatic mode. 	

24 Automatic signal connected to (A2) (Refer to INTERFACE09 for related setup)

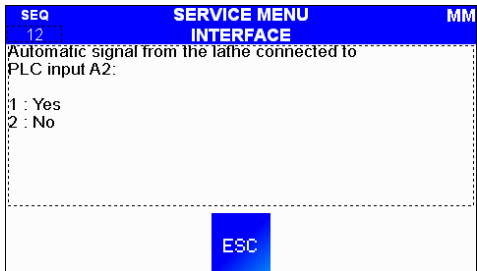
<p>Defines if A2 signal (lathe in auto mode) is connected.</p> <ol style="list-style-type: none"> 1 If INTERFACE09=1, Chuck signal A1 and Auto signal A2 enables the feeding process. If INTERFACE09=2, Chuck signal A1, Auto signal A2 and Push signal A4 enables feeding process. 2 If INTERFACE09=1, Chuck signal A1 only enables feeding process. If INTERFACE09=2, Chuck signal A1 and Push signal A4 enables feeding process. <p>* Refer to the timing chart <2> on 8.6.2.1</p>	
---	---

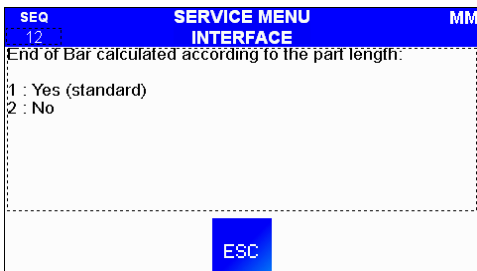
<p>31 EOB calculated according to part length (Refer to INTERFACE17, 18, 19, 20, 32, 33 for related setup)</p>	
<p>Defines how the End of Bar position is calculated.</p> <ol style="list-style-type: none"> 1 The End of Bar position is calculated by “DIAMETER & LENGTH: PART LENGTH” setup. 2 The End of Bar position is calculated by “END OF BAR” setup and pusher position. <p>* Refer to the timing chart <4> on 8.6.2.1</p>	

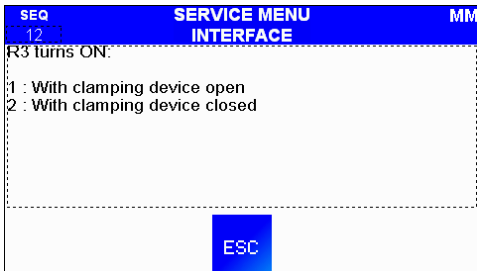
<p>32 R3 turns ON (Refer to INTERFACE17, 18, 19, 20, 31, 33 for related setup)</p>	
<p>Defines when the End of Bar signal R3 turns ON.</p> <ol style="list-style-type: none"> 1 R3 signal turns ON when the pusher reaches the End of Bar position during chuck opened. 2 R3 signal turns ON when the last part is machined with chuck closed after the End of Bar. 	

* Refer to the timing chart <4> on 8.6.2.1

33 R3 turns ON at EOB and turns OFF

(Refer to INTERFACE17, 18, 19, 20, 31, 32 for related setup)

Defines when R3 turns OFF.

- 1 R3 signal turns OFF during end of Bar when A3 signal is activated and the pusher retracts back to home position.
- 2 R3 signal turns OFF when the new bar is loaded into the channel.

* Refer to the timing chart <4> on 8.6.2.1

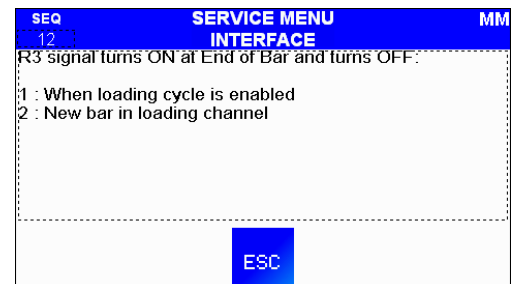

34 R2 While In Synchronization Ready

Defines if R2 signal turns ON when headstock synchronization is enabled.

1. R2 signal is OFF.
2. R2 signal is pulsed for 1 second to confirm M-code for headstock synchronization enabled.

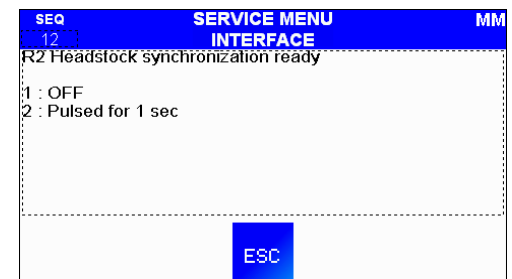

43 R5 is

Defines function of R5 signal

- 1 Used for Auxiliary End of Bar signal.
- 2 Used for spindle Inching signal
- 3 Used for Magazine Empty

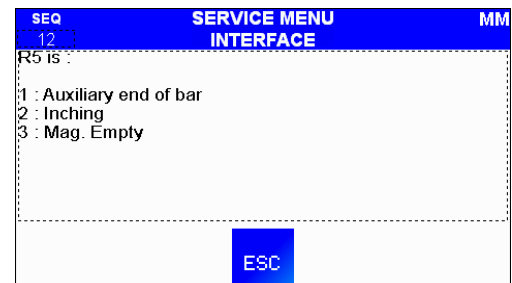

44 Lathe door signal logic setup

- 1 Lathe door signal lit, the door is open.
- 2 Lathe door signal lit, the door is closed.

SEQ	SERVICE MENU	MM
12	INTERFACE	
Lathe door signal (X37) is active:		
1 : With door open		
2 : With door closed		
ESC		

45 A2 signal logic setup

- 1 A2 signal lit, the lathe is in automatic mode.
- 2 A2 signals lit, the lathe is not in automatic mode.

SEQ	SERVICE MENU	MM
12	INTERFACE	
A2 is :		
1 : NO		
2 : NC		
ESC		

46 PUSH signal (A4) logic setup

PUSH signal is used to control pusher pushing forward during machining. Pushing while chuck opens for feeding and closed for machining are included.

- 1 A4 Push signal lit, the lathe commands pushing.
- 2 A4 Push signal lit, the lathe commands not pushing.

SEQ	SERVICE MENU	MM
12	INTERFACE	
A4 is :		
1 : NO		
2 : NC		
ESC		

47 Alarm signal (R1) logic setup

Defines the situation when R1 is ON

1. No alarm
2. Alarm

SEQ	SERVICE MENU	MM
12	INTERFACE	
R1 is ON when		
1 : No alarm		
2 : Alarm		
ESC		

49 A2 Signal definition

1. A2 signal lit, the lathe is in automatic mode.
 2. A2 signals lit, the lathe is abnormal.

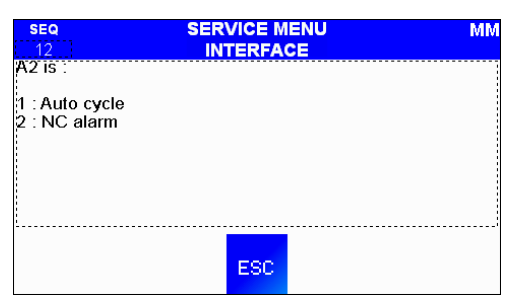

50 Retraction safety logic setup

Retraction safety switches are to confirm the bar feeder is either retracted or in a safe position.

1. Retraction safety switch lit, the retraction system is not safely positioned.
 2. Retraction safety switch lit, the retraction system is safely positioned.

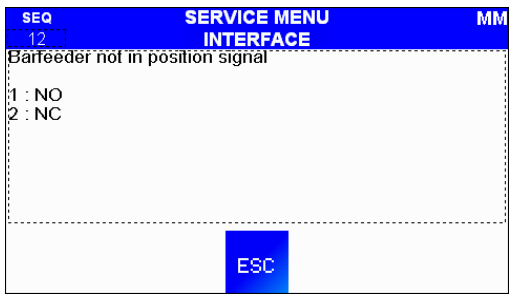

74 & 75 Time for clamping (sec.)

Defines the time it takes for the chuck of the lathe to be physically closed or open.

74 TIME FOR CLAMPING DEVICE TO CLOSE (SEC)
 Time for the chuck to close.

75 TIME OFR CLAMPING DEVICE TO OPEN (SEC)
 Time for chuck to open.

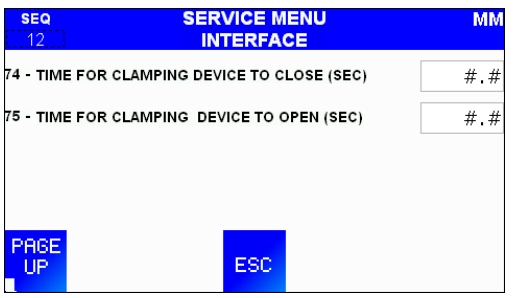

F3: Mode

NORMAL OPERATION

SIMULATION MODE
 Attention! This mode is used for simulation purpose only. It allows to test run the bar feeder without taking the lathe interface into consideration. No bar stock should be present on the magazine or in the bar feeder

TEST INTERFACE MODE
 This mode is selected for test purpose only. It allows testing the interface signals (Input/Outputs) of the PLC.

RUN OFF
 LNS factory test only. It's only used for special test.

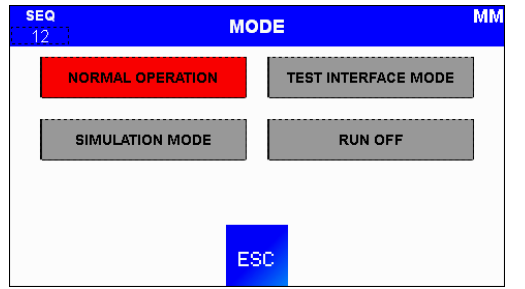

8.5.2.1 Timing chart reference

<1> Start loading signal A3

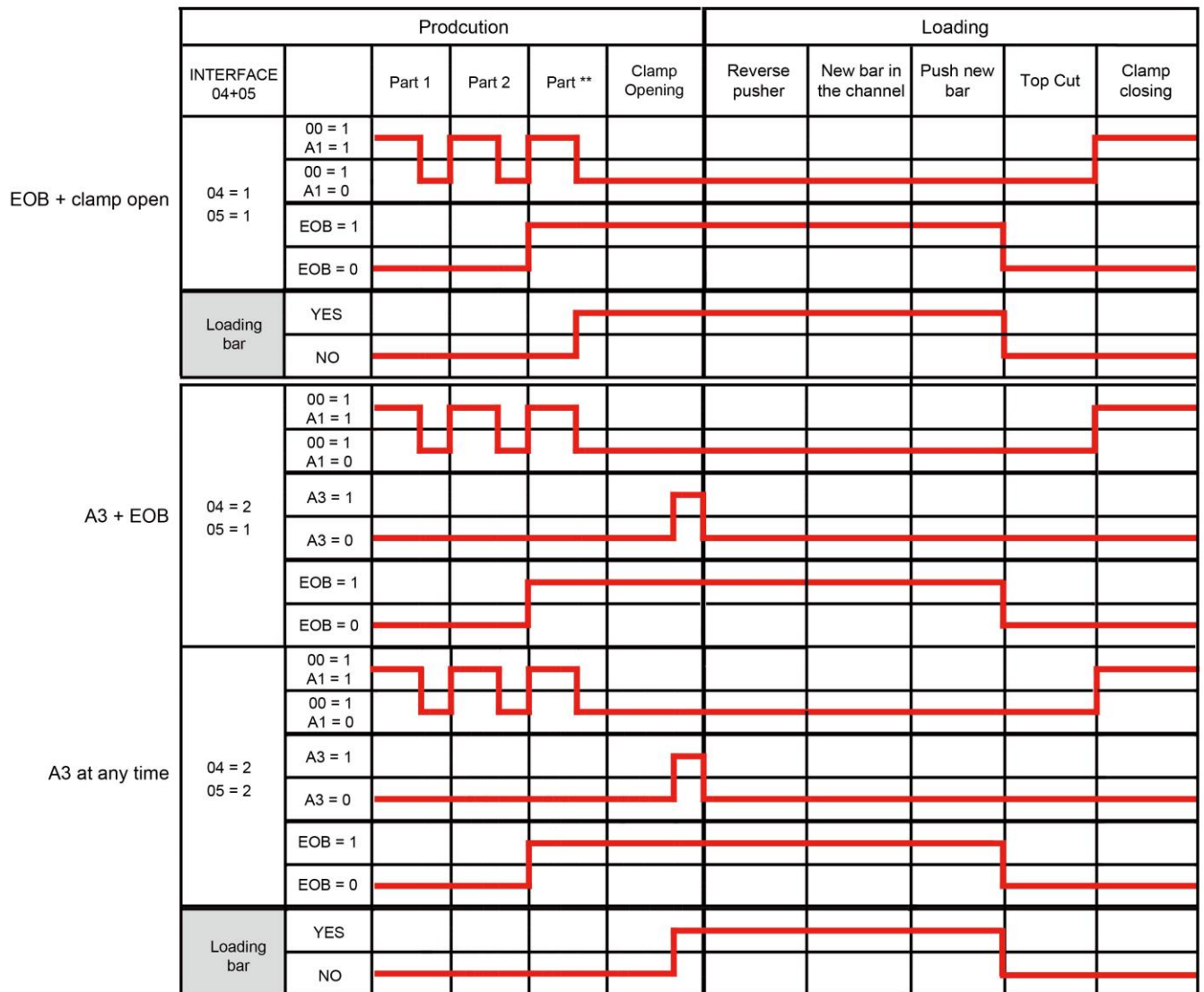

<2> Push signal A4

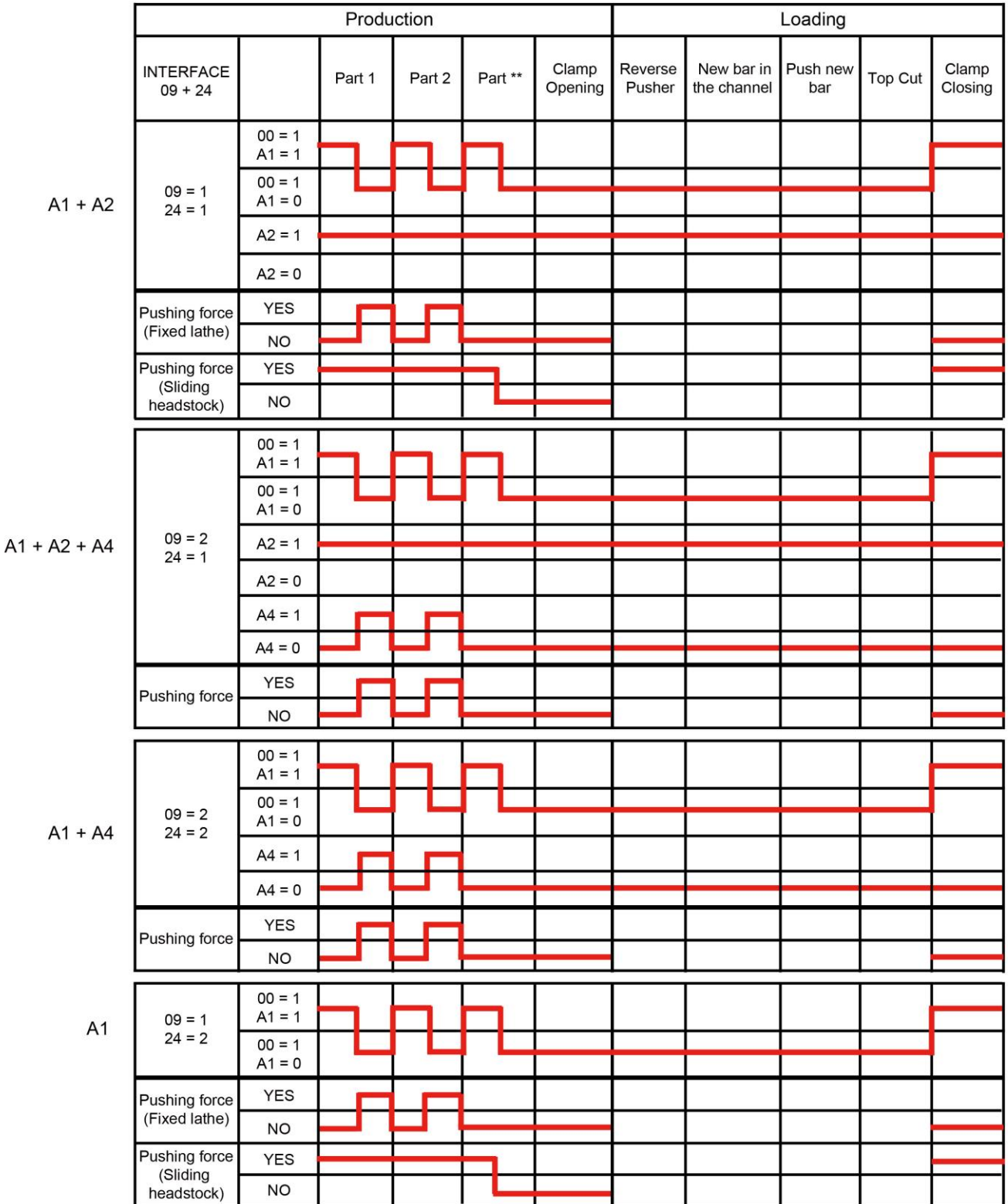

<3> Start signal R2

INTERFACE13			INTERFACE14			INTERFACE15		
SEQ	SERVICE MENU	MM	SEQ	SERVICE MENU	MM	SEQ	SERVICE MENU	MM
12	INTERFACE		12	INTERFACE		12	INTERFACE	
R2 while in production cycle:			R2 during End of Bar:			R2 on at Top-Cut position:		
1 : OFF 2 : ON			1 : OFF 2 : ON			1 : Until the clamping device is closed 2 : Pulsed for 2 seconds		
ESC			ESC			ESC		

Production						Loading				
INTERFACE 13/14/15	R2	Part 1	Part 2	Part **	Clamp Opening	Reverse Pusher	New bar in the channel	Push new bar	Top Cut	Clamp Closing
13 = 1 14 = 1 15 = 1	R2 ON									
	R2 OFF	-----								-----
13 = 2 14 = 1 15 = 1	R2 ON	-----								
	R2 OFF		-----	-----						
13 = 1 14 = 2 15 = 1	R2 ON			-----						
	R2 OFF	-----			-----					
13 = 1 14 = 1 15 = 2	R2 ON								-----	
	R2 OFF	-----								-----

INTERFACE16

SEQ	SERVICE MENU	MM
12	INTERFACE	
R2 signal to confirm:		
1 : Top-Cut only 2 : Top-Cut and Part Feed		
ESC		

Production						Loading				
INTERFACE 16	R2	Part 1	Part 2	Part **	Clamp Opening	Reverse Pusher	New bar in the channel	Push new bar	Top Cut	Clamp Closing
16 = 1	R2 ON									
	R2 OFF	-----								-----
16 = 2	R2 ON	-----	-----	-----						
	R2 OFF	-----	-----	-----	-----					
A1	A1 = 1	-----	-----	-----						
	A1 = 0	-----	-----	-----						

<4> End of Bar signal R3

<p>INTERFACE17</p> <p>SEQ 12 SERVICE MENU INTERFACE MM</p> <p>R3 signal latches at End of Bar:</p> <p>1 : Yes 2 : No</p> <p>ESC</p>	<p>INTERFACE18</p> <p>SEQ 12 SERVICE MENU INTERFACE MM</p> <p>R3 signal turns on at End of Bar and turns off:</p> <p>1 : When loading cycle is enabled 2 : Guiding channel open - Clamping device open</p> <p>ESC</p>	<p>INTERFACE19</p> <p>SEQ 12 SERVICE MENU INTERFACE MM</p> <p>R3 signal turns ON at End of Bar and turns OFF:</p> <p>1 : When loading cycle is enabled 2 : Barstock in Top-Cut position</p> <p>ESC</p>	<p>INTERFACE20</p> <p>SEQ 12 SERVICE MENU INTERFACE MM</p> <p>R3 signal pulses for 2 seconds at End of Bar:</p> <p>1 : No 2 : Yes</p> <p>ESC</p>
<p>INTERFACE31</p> <p>SEQ 12 SERVICE MENU INTERFACE MM</p> <p>End of Bar calculated according to the part length:</p> <p>1 : Yes (standard) 2 : No</p> <p>ESC</p>	<p>INTERFACE32</p> <p>SEQ 12 SERVICE MENU INTERFACE MM</p> <p>R3 turns ON:</p> <p>1 : With clamping device open 2 : With clamping device closed</p> <p>ESC</p>	<p>INTERFACE33</p> <p>SEQ 12 SERVICE MENU INTERFACE MM</p> <p>R3 signal turns ON at End of Bar and turns OFF:</p> <p>1 : When loading cycle is enabled 2 : New bar in loading channel</p> <p>ESC</p>	



Production						Loading				
INTERFACE 17/18/19/20/ 31/32/33	R3	Part 1	Part 2	Part **	Clamp Opening	Reverse Pusher	New bar in the channel	Push new bar	Top Cut	Clamp Closing
17/18/19/20/ 31/32/33 = 1	R3 ON									
	R3 OFF									
17 = 2 18/19/20/ 31/32/33 = 1	R3 ON									
	R3 OFF									
18 = 2 17/19/20/ 31/32/33 = 1	R3 ON									
	R3 OFF									
19 = 2 17/18/20/ 31/32/33 = 1	R3 ON									
	R3 OFF									
20 = 2 17/18/19/31/ 32/33 = 1	R3 ON									
	R3 OFF									
31 = 2 17/18/19/20/ 32/33 = 1	R3 ON									
	R3 OFF									
32 = 2 17/18/19/20/ 31/33 = 1	R3 ON									
	R3 OFF									
33 = 2 17/18/19/ 20/31/32 = 1	R3 ON									
	R3 OFF									
EOB	YES									
	NO									

9 TROUBLE SHOOTING GUIDE

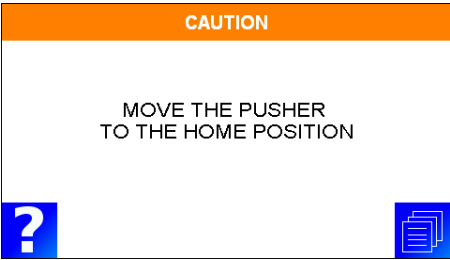
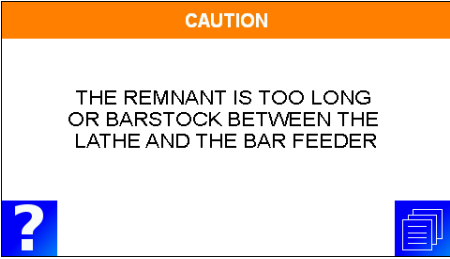

This chapter lists all the error messages, their description and a brief troubleshooting. The error messages aim to remind the operator that an abnormal situation is taking place or has happened. Whenever an error message is activated please follow the description and troubleshooting to check the problem. If necessary contact us or one of our representatives for technical support.

9.1 WARNING MESSAGES

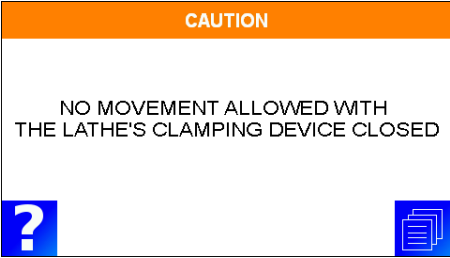
Warning messages are designed to remind users of the bar feeder status. Under the following conditions there will be a warning message but the alarm signal output (Y04, R1) of the bar feeder will not send an alarm signal to the lathe. Please follow the help instructions guide to clear the warning messages.

Warning messages	
<p>Description Pusher is at the wrong position.</p> <p>Troubleshooting Manually return pusher to its home position.</p>	 <p>The screenshot shows a warning message box with an orange header containing the word "CAUTION". The main text reads "MOVE THE PUSHER TO THE HOME POSITION". There is a blue question mark icon on the left and a blue document icon on the right.</p>
<p>Description The remnant is too long or barstock is between the lathe and the bar feeder.</p> <p>Troubleshooting Manually remove the remnant.</p>	 <p>The screenshot shows a warning message box with an orange header containing the word "CAUTION". The main text reads "THE REMNANT IS TOO LONG OR BARSTOCK BETWEEN THE LATHE AND THE BAR FEEDER". There is a blue question mark icon on the left and a blue document icon on the right.</p>
<p>Description</p> <p>Lathe chuck is closed, press  or  is invalid.</p> <p>Troubleshooting</p> <ol style="list-style-type: none"> 1. Open lathe chuck. 2. Check INTERFACE00 setup related to lathe chuck signal. 	 <p>The screenshot shows a warning message box with an orange header containing the word "CAUTION". The main text reads "NO MOVEMENT ALLOWED WITH THE LATHE'S CLAMPING DEVICE CLOSED". There is a blue question mark icon on the left and a blue document icon on the right.</p>

<p>Description Bar feeder is unable to start in AUTO mode when the lathe chuck is open.</p> <p>Troubleshooting</p> <ol style="list-style-type: none"> 1. Close the lathe chuck. 2. Check if INTERFACE00 setup corresponds to lathe chuck signal. 	<p>CAUTION</p> <p>THE LATHE'S CLAMPING DEVICE MUST BE CLOSED PRIOR TO STARTING AUTOMATIC CYCLE !</p>
<p>Description Bar feeder detects the lathe door is open. Once receiving the signal the servo motor will stop operating.</p> <p>Troubleshooting Close the lathe door.</p>	<p>CAUTION</p> <p>LATHE DOOR IS OPEN</p>
<p>Description When the bar feeder is in manual mode, main cover is open and the guiding channel is closed.</p> <p>Troubleshooting Manually close main access cover.</p>	<p>CAUTION</p> <p>MAIN ACCESS COVER OPEN</p>
<p>Description Bar feeder unable to start in AUTO mode when the guiding channel is open and the lathe chuck is closed.</p> <p>Troubleshooting</p> <ol style="list-style-type: none"> 1. Open the lathe chuck. 2. Check if "INTERFACE00" setup corresponds to chuck signal. 	<p>CAUTION</p> <p>THE LATHE'S CLAMPING DEVICE MUST BE OPENED PRIOR TO STARTING !</p>
<p>Description Manually press channel close button or AUTO START button when the short pusher is not yet at "BAR LOADING REAR LIMITER POSITION". This message will then arise.</p> <p>Trouble shooting Press "Load / Unload" button to clear this message.</p>	<p>CAUTION</p> <p>PUSHER POSITIONING ERROR! PRESS "LOAD" OR "UNLOAD" BUTTON TO CLEAR THE ERROR</p>
<p>Description This message will arise when manually press loading button.</p>	<p>CAUTION</p> <p>LOADING IN PROGRESS ...</p>

<p>Description This message will arise when manually press unloading button.</p>	<p>The screenshot shows a white background with an orange header bar containing the word "CAUTION" in white. Below the header, the text "UNLOADING IN PROGRESS ..." is centered. In the bottom left corner, there is a blue square icon with a white question mark. In the bottom right corner, there is a blue square icon with a white document symbol.</p>
<p>Description The bar measuring device (front stopper) is not ready when AUTO + START  is pressed this message will be displayed.</p> <p>Troubleshooting Press channel open  to clear this message.</p>	<p>The screenshot shows a white background with an orange header bar containing the word "CAUTION" in white. Below the header, the text "BAR MEASURING STOP NOT READY (SQ1)" is centered. In the bottom left corner, there is a blue square icon with a white question mark. In the bottom right corner, there is a blue square icon with a white document symbol.</p>
<p>Description Bar feeder is already switched to AUTO mode but it doesn't receive the Lathe AUTO signal A2.</p> <p><Note> Only applied when "INTERFACE24: Automatic signal connected to (A2)" is set 1.</p> <p>Troubleshooting</p> <ol style="list-style-type: none"> 1. Switch lathe to AUTO mode. 2. If A2 signal is not used, please change the INTERFACE24 setup. <p>Check if the "INTERFACE45: AUTO signal" setup is correct.</p>	<p>The screenshot shows a white background with an orange header bar containing the word "CAUTION" in white. Below the header, the text "LATHE IN MANUAL MODE" is centered. In the bottom left corner, there is a blue square icon with a white question mark. In the bottom right corner, there is a blue square icon with a white document symbol.</p>

9.2 ERROR MESSAGE MAP

The following flow chart shows a basic sequence of event that includes the alarms that can occur during production operation (bar feeder + lathe).

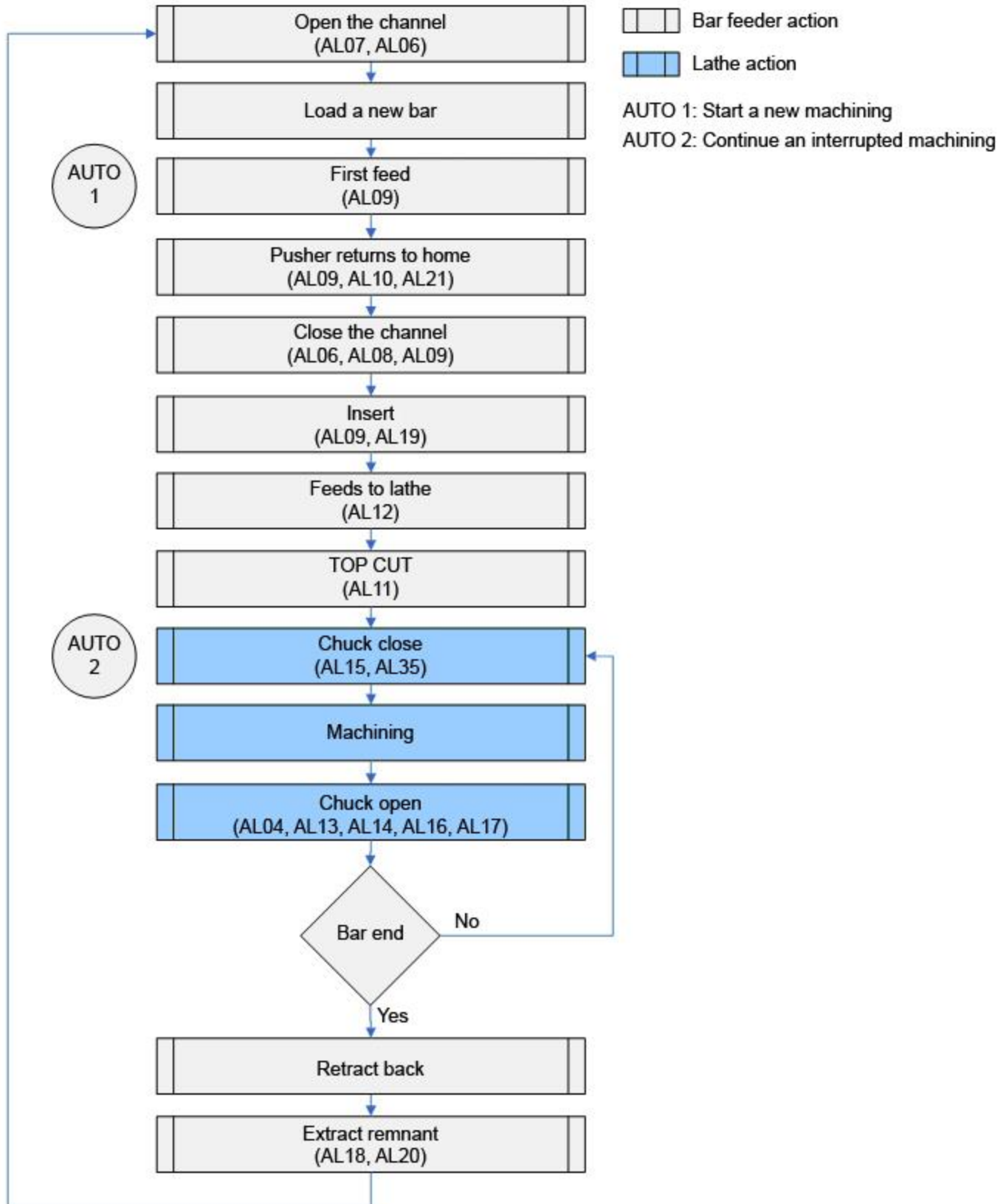

9.3 ERROR MESSAGE DESCRIPTION AND TROUBLE SHOOTING GUIDE

When an error occurs the corresponding alarm message will be displayed on the HMI screen. Follow the troubleshooting instructions below to solve the problems and clear the alarms.

To clear the alarm after troubleshooting presses STOP.

If the alarm message remains active please contact LNS or one of its representatives for further technical assistance.

AL01 Emergency Stop Line is open!

Description

The emergency stop circuit includes:

- Emergency stop button on HMI (STP1)
- Emergency stop circuit of the lathe
- Main circuit-breaker QM1
- Contactor K1

During normal operation the contactor K1 is energized and continuously sending signal to PLC input X10. Whenever this circuit is open K1 will de-energize and the signal to PLC input contact X10 is Off.

Sequence of actions:

1. The 220V AC to the servo amplifier is interrupted.
2. All PLC output signals are interrupted except for Y20 (input signal of alarm relay R1).
3. The alarm AL01 is displayed on the HMI screen.

If the relay K8 (DCS relay) is installed press MANUAL button on the HMI after powering up the bar feeder otherwise this error message will be displayed.

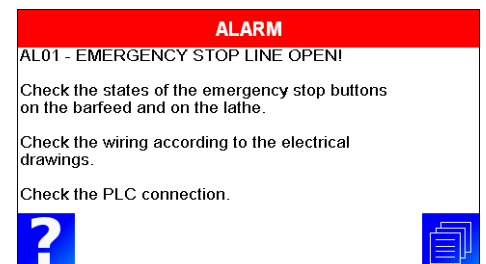

Trouble shooting

1. Check if the emergency stop on HMI (STP1) is pressed. If yes release it.
2. Check if the emergency stop circuit on the lathe is open. If yes clear all lathe alarms.
3. Check if circuit-breaker (QM1) has tripped. If yes reset it.
4. Check if A1 and A2 of contactor (K1) have 24 VDC.
5. Press "STOP" button on HMI to clear the alarm.

AL02 Main Access Cover Open!

Description

This alarm only applies when the main access cover safety switch SQ11 is installed.

When the guiding channel is open and the main access cover is opened the CE safety switch SQ11 is disengaged. This alarm will be displayed.

Troubleshooting

1. Close the main access cover.
2. If the cover is already closed:
 - (1) Check if there is something blocking the cover or if the cover is bent to prevent the sensor SQ11 to operate.
 - (2) Check if the switch SQ11 is defective.
 - (3) Press "STOP" key on HMI to clear the alarm.

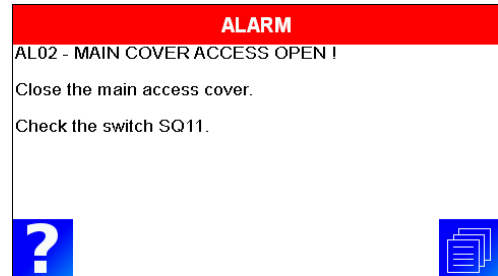

AL03 Bar Feeder Retracted Or Not In Its Working Position

Description

Following the operation procedures described on 7.12.2, when the bar feeder is retracted and both of the retraction safety switches "SQ10" are engaged, the alarm message will be generated.

* This alarm only applies to bar feeder with optional Z-axis retraction.

Trouble shooting

1. Position the bar feeder in its working position.
2. Check if the safety switches are defective or misadjusted.
3. Press the STOP button on the remote control to reset the alarm.

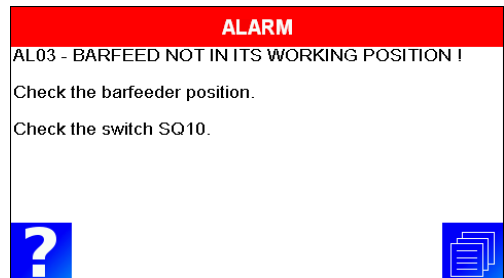

AL04 Oil Pressure Failure!

Description

When oil pump is operating but switch SP2 doesn't detect any oil pressure in 60 seconds (SP2 OFF). This alarm only shown after the lathe finishes machining a workpiece and chuck is open.

This switch is optional so this error message is only available when bar feeder installed this switch.

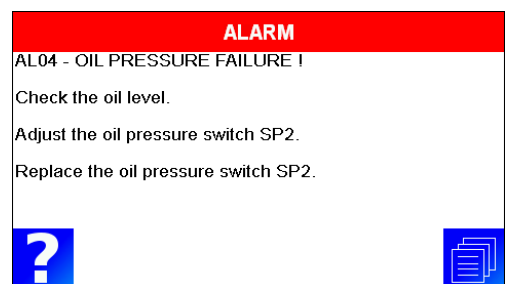

Trouble shooting

1. Check if oil **pump** can supply oil smoothly.
2. Replace oil pressure switch SP2 if it's broken.
3. Press "STOP" button on remote control to remove the alarm.

AL05 Air Pressure Failure!**Description**

SP1 pressure switch does not detect any air pressure within 5 seconds. The problem is generated anytime air pressure is not sufficient below 3 bar (45 psi).

Troubleshooting

1. Adjust the air pressure between 3 bar and max. 6 bar.
2. Adjust or replace the pressure switch SP1 if defective.
3. Press "STOP" button on HMI to clear the alarm.

ALARM

AL05 - AIR PRESSURE FAILURE !

Check the air pressure (min. 3 bar, max. 6 bar).

Adjust the air pressure switch SP1.

Replace the air pressure switch SP1.

**AL06 Guiding Channel Switch Failure! (SQ3/SQ4)****Description**

Both guiding channel switches SQ3 and SQ4 are simultaneously activated or deactivated.

Troubleshooting

1. Check if the SQ3 or SQ4 switches are defective or misadjusted.
2. Press "STOP" button on HMI to clear the alarm.

ALARM

AL06 - GUIDING CHANNEL OPEN/CLOSE SWITCH FAILURE! (SQ3/SQ4)

Check the switches SQ3 and SQ4.

**AL07 Guiding Channel Open Failure! (SQ3)****Description**

When the bar feeder guiding channel starts to open (PLC output Y05 ON) 5.0 seconds later the channel open switch SQ3 signal is not present or the channel close switch SQ4 signal remains ON.

Trouble shooting

1. Check if there is something is preventing the guiding channel to open.
2. Check if switch SQ3 if defective or misadjusted.
3. Check if the air pressure is too low or if the guiding channel opening cylinder is too slow.
4. Press "STOP" button on HMI to clear the alarm.

ALARM

AL07 - SQ3 SWITCH FAILURE DURING THE CHANNEL OPENING !



Check the switch SQ3.





AL08 Guiding Channel Close Failure! (SQ4)	
<p>Description</p> <p>When the bar feeder guiding channel starts closing (PLC Output Y06 ON) 5.0 seconds later the channel closed switch SQ4 signal is not present or if the channel open switch SQ3 signal remains ON.</p>	<div style="border: 1px solid black; padding: 5px;"> <div style="background-color: red; color: white; text-align: center; padding: 2px;">ALARM</div> <p>AL08 - SQ4 SWITCH FAILURE DURING THE CHANNEL CLOSING !</p> <p>Check the switch SQ4.</p> <div style="display: flex; justify-content: space-between; align-items: center; margin-top: 20px;"> ? ☰ </div> </div>
<p>Troubleshooting</p> <ol style="list-style-type: none"> 1. Check if there is something preventing the guiding channel to close. 2. Check if switch SQ4 is defective of misadjusted. 3. Check if the air pressure is too low or if the channel closing air cylinder is too slow. 4. Press “STOP” button on HMI to clear the alarm. 	

AL09 Measuring Cell Failure!	
<p>Description</p> <p>When the bar feeder is in automatic mode and ready for feeding the bar to “TOP CUT POSITION” the switch SQ1 signal does not reset (SQ1 OFF).</p>	<div style="border: 1px solid black; padding: 5px;"> <div style="background-color: red; color: white; text-align: center; padding: 2px;">ALARM</div> <p>AL09 - BAR MEASURING CELL FAILURE! (SQ1)</p> <p>Check the switch SQ1.</p> <div style="display: flex; justify-content: space-between; align-items: center; margin-top: 20px;"> ? ☰ </div> </div>
<p>Troubleshooting</p> <ol style="list-style-type: none"> 1. Check if the bar stock is present or for mechanical interference with the bar measuring device. 2. Check if the bar measuring device is lose. 3. Check if the bar measuring device cylinder is defective. 4. Check if the bar measuring device switch SQ1 is defective of misadjusted. 5. Press “STOP” button on HMI to clear the alarm. 	

AL10 Home Position Switch Failure! (SQ2)	
<p>Description</p> <p>When the pusher is at home position and the current position reading is “0”, switch SQ2 signal is not present.</p>	<div style="border: 1px solid black; padding: 5px;"> <div style="background-color: red; color: white; text-align: center; padding: 2px;">ALARM</div> <p>AL10 - SQ2 SWITCH (HOME POSITION) FAILURE!</p> <p>Check the switch SQ2.</p> <div style="display: flex; justify-content: space-between; align-items: center; margin-top: 20px;"> ? ☰ </div> </div>
<p>Troubleshooting</p> <ol style="list-style-type: none"> 1. Verify if the pusher is physically at home position and then check if the switch SQ2 is operational. 2. If the pusher is not physically at home position the servo motor encoder may be defective. 3. Press “STOP” button on HMI to clear the alarm. 	

<i>AL11 Lathe Did Not Resume Production Cycle!</i>	
<p><u>Description</u></p> <p>Once the bar stock reaches "TOP CUT POSITION" and confirmation signal is sent to the lathe (R2) the chuck doesn't close within 60 sec. This alarm only applies to TOP CUT process rather than general bar feeding process.</p> <p><u>Explanation</u></p> <p>After "TOP CUT POSITION" is reached and confirmation signal is sent to the lathe (R2) the chuck doesn't close within 60 seconds. This is only detected during TOP CUT process so this message will not be activated during general feeding process.</p>	<div style="background-color: red; color: white; text-align: center; padding: 2px;">ALARM</div> <p>AL11 - LATHE DID NOT RESUME ITS PRODUCTION CYCLE !</p> <p>Check if the lathe receives START signal from the bar feeder.</p> <p>Check if the bar feeder receives CHUCK signal.</p> <div style="display: flex; justify-content: space-between; align-items: center;">   </div>
<p><u>Troubleshooting</u></p> <ol style="list-style-type: none"> 1. Check if the lathe receives START (R2) signal from the bar feeder. 2. Check if the bar feeder receives CHUCK signal. 3. Check if the interface cable connection status is functioning. 4. Press "STOP" button on HMI to clear the alarm. 	

<i>AL12 Bar Loading Time Elapsed!</i>	
<p><u>Description</u></p> <p>The pusher cannot advances the bar stock to "TOP CUT POSITION" after 20 try-outs.</p>	
<p><u>Troubleshooting</u></p> <ol style="list-style-type: none"> 1. Check if the bar feed alignment is correct. 2. Check if the channel and front tube size are correct or if obstructed. 3. Check if the front rest is clamping the bar. 4. Check if the lathe spindle is obstructed. 5. Check if the lathe chuck is too tight due to the size being incorrect or there are burrs inside the chuck or at the end of the bar. 6. Check if "TOP CUT POSITION" setup is incorrect. 7. Check if the bar measuring device of the bar feeder is malfunctioning. 8. Press "STOP" button on HMI to clear the alarm. 	<div style="background-color: red; color: white; text-align: center; padding: 2px;">ALARM</div> <p>AL12 - SAFETY TIME FOR LOADING ELAPSED !</p> <p>Remove the bar stock from the spindle.</p> <p>Restart the top cut cycle.</p> <p>Check the part settings.</p> <div style="display: flex; justify-content: space-between; align-items: center;">   </div>

AL13 Part Feed Out Time Elapsed!

Description

If the PLC input X40 does not activate within 30 sec, receiving the CHUCK signal from the lathe will generate this alarm.

Troubleshooting

1. Check if the interface connected to the PLC input contact X40 is ON.
2. Press "STOP" button on HMI to clear the alarm.

AL14 Part Feed Out Too Long!

Description

The bar feeder continuously monitors the pusher moving distance while the chuck of the lathe is open (the bar feeder is currently feeding bar stock). If the distance exceeds the "Too long collet open" setup, this alarm will turn on.

Only valid with fixed headstock lathe.

Troubleshooting

1. Check if the bar stock is disconnected from the pusher collet.
2. Check if "Too long collet open" setup is incorrect.
3. Check if the transmission mechanism or chain is broken.
4. Check if the bar measuring device is defective.
5. Press "STOP" button on HMI to clear the alarm.

AL15 Part Feed Out Too Short!

Description

The bar feeder monitors the pusher moving distance from the time the chuck opens to the time the chuck closes (the lathe is currently proceeding machining). Once the chuck closes and if the distance is 5 mm shorter than "part length" this alarm will turn on.

Only valid with fixed headstock lathe.

Trouble shooting

1. Check if the alignment of the bar feeder is correct.
2. Check if the channel and front tube sizes are correct and if obstructed.

<ol style="list-style-type: none"> 3. Check if the pusher is bent 4. Check if the lathe spindle is obstructed. 5. Check if the front rest is clamping on the bar. 6. Check if the lathe chuck is too tight due to the size being incorrect or for any burrs inside the chuck or on the bar. 7. Check if the timer for controlling the chuck open/close is too short. 8. Check if the measuring device is defective or malfunctioning. 9. Check if “End of Bar” position is setup correctly. 10. Press “STOP” button on HMI to clear the alarm. 	
--	--

AL16 Barstock moving forward while headstock moving Backwards!

Description

This check is activated when the chuck is open during the machining process. Detection starts by comparing the current position and the position of pusher while the chuck is open. If the pusher retracts 4mm back or exceeds “Too long collet open”, the alarm will be generated.

Trouble shooting

1. Check if the bar stock is disconnected from the pusher collet.
2. Check if “Too long collet open” setup is incorrect.
3. Check if the transmission mechanism or the chain is broken.
4. Check if the bar measuring device is malfunctioning or the cut off tool is broken (if the operator is using the cut off tool as a stopper).
5. Check if “End of Bar” position is setup correctly.
6. Press “STOP” button on HMI to clear the alarm.



ALARM

AL16 - BARSTOCK MOVING DURING HEADSTOCK REVERSE !

Check if the bar stock escapes from finger chuck.

Check if <Too long_#> setup is incorrect.

Check if the stopper position is incorrect or the cut off tool is broken.

AL17 Headstock Travel Shorter Than Expected, The Pusher Lost the Bar stock!

Description

The bar feeder monitors the pusher moving distance from the time the chuck closes to the time the chuck opens. If the distance is shorter than the “Too short” setup, this alarm will be generated.

Only valid with Swiss type lathe.

ALARM

AL17 - HEADSTOCK TRAVEL SHORTER THAN PART LENGTH! THE PUSHER MAY HAVE LOST THE BAR STOCK!

Check if <Too short> setup is incorrect.



Check if the synchronization device works correctly.

Check if pusher length is long enough.





<p><Note> To disable this function <Too short>, set the value "0".</p>	
<p><u>Troubleshooting</u></p> <ol style="list-style-type: none"> 1. Check if the bar feed alignment is correct. 2. Check if the lathe chuck is too tight due to the incorrect size or there are burrs inside the chuck or on the bar. 3. Check if <Too short> setup on "PART SETUP" is incorrect. 4. Check if "End of Bar" position setup is incorrect. 5. Check if the headstock synchronization system works correctly. 6. Check pusher length. 7. Check if bar stock is disconnected from the pusher collet. 8. Press "STOP" button on HMI to clear the alarm. 	

AL18 The Pusher Lost The Barstock While Moving To Its Home Position!

<p><u>Description</u></p> <p>Material clamping device clamps and detects the bar stock by sensor SQ6. If SQ6 doesn't detect any material, this alarm will arise.</p>	<div style="background-color: red; color: white; text-align: center; padding: 2px;">ALARM</div> <p>AL18 - PUSHER LOST THE BAR STOCK WHILE MOVING BACK TO HOME POSITION !</p> <p>Check if the lathe chuck collect is too tight or there are burrs left on the remnant surface.</p> <p>Check if sensor SQ6 is broken.</p> <div style="display: flex; justify-content: space-between; align-items: center;">   </div>
<p><u>Troubleshooting</u></p> <ol style="list-style-type: none"> 1. Check if the lathe chuck collect is too tight or for any burrs on the remnant surface. 2. Check pusher collet size 3. Check if switch SQ6 on clamping vise is defective of misadjusted. 4. Press "STOP" button on HMI to clear the alarm. 	

AL19 Barstock Insertion Malfunction!

<p><u>Description</u></p> <ol style="list-style-type: none"> 1. The pusher repeatedly tries to insert the bar stock for 5 times without reaching the 35 mm insertion position to insert the bar stock. 2. If "BAR INSERT CHECK"=NO and insertion procedure is completed the pusher will move back and forth and the clamping vise will detect the bar stock. If no bar is detected the alarm will be generated. 	<div style="background-color: red; color: white; text-align: center; padding: 2px;">ALARM</div> <p>AL19 - BARSTOCK INSERTION MALFUNCTION !</p> <p>Check if the dimension of finger chuck agrees with the bar stock.</p> <div style="display: flex; justify-content: space-between; align-items: center;">   </div>
--	---

<p><u>Troubleshooting</u></p> <ol style="list-style-type: none"> 1. Check if the dimension of finger chuck agrees with the bar stock. 2. Press “STOP” button on HMI to clear the alarm. 	
<i>AL20 Barstock Not Extracted From The Collet!</i>	
<p><u>Description</u></p> <p>The remnant did not drop down in the remnant tray. Once the bar extraction cycle is completed SQ6 (vise switch) is still detecting bar stock presence in the clamping vise.</p>	
<p><u>Troubleshooting</u></p> <ol style="list-style-type: none"> 1. Check if the pusher collet fits the size of the bar stock. 2. Check if the bar end is clear of burrs. 3. Check if the clamping device is defective. 4. Check if the air pressure is too low resulting in insufficient clamping force. 5. Check if switch SQ6 is defective or misadjusted. 6. Press “STOP” button on HMI clear the alarm. 	<div style="border: 1px solid black; padding: 5px;"> <p style="text-align: center; background-color: red; color: white; margin: 0;">ALARM</p> <p style="margin: 0;">AL20 - BARSTOCK NOT EXTRACTED FROM THE COLLET !</p> <p style="margin: 0;">Check if the bar stock tip is smooth enough.</p> <p style="margin: 0;">Check if the clamping device is broken.</p> <p style="margin: 0;">Check if sensor SQ6 is broken.</p> <div style="display: flex; justify-content: space-between; align-items: center; margin-top: 10px;"> ? ☰ </div> </div>
<i>AL21 Bar Magazine Empty!</i>	
<p><u>Description</u></p> <p>During the short loading flag bar newly loaded bar positioning no bar presence is detected. This alarm will be generated if switch SQ6 is ON (no material).</p>	
<p><u>Troubleshooting</u></p> <ol style="list-style-type: none"> 1. Check if the magazine is out of bar stock and re-fill accordingly. 2. Check if the switch SQ6 is defective or misadjusted. 3. Press “STOP” button on HMI to clear the alarm. 	<div style="border: 1px solid black; padding: 5px;"> <p style="text-align: center; background-color: red; color: white; margin: 0;">ALARM</p> <p style="margin: 0;">AL21 - BARSTOCK MAGAZINE EMPTY !</p> <p style="margin: 0;">Check if the magazine is out of bar stock and re-fill accordingly.</p> <p style="margin: 0;">Check if the sensor SQ6 is broken.</p> <div style="display: flex; justify-content: space-between; align-items: center; margin-top: 10px;"> ? ☰ </div> </div>
<i>AL22 Material Present In Simulation Cycle!</i>	
<p><u>Description</u></p> <p>When switching the bar feeder in simulation mode no material should be present.</p>	
<p><u>Troubleshooting</u></p> <ol style="list-style-type: none"> 1. Check if the switch SQ6 on the clamping vise is defective or misadjusted. 2. Remove material is present in the bar feeder 	<div style="border: 1px solid black; padding: 5px;"> <p style="text-align: center; background-color: red; color: white; margin: 0;">ALARM</p> <p style="margin: 0;">AL22 - BARSTOCK DETECTED IN SIMULATION MODE !</p> <p style="margin: 0;">Check if the sensors on clamping vise are broken.</p> <div style="display: flex; justify-content: space-between; align-items: center; margin-top: 10px;"> ? ☰ </div> </div>

3. Press "STOP" button on HMI to clear the alarm.

AL24 Top Cut Positioning Error!

Description

1. During the positioning of the bar in the insertion position the front of bar already passed the "TOP CUT" position.
2. During the positioning of the bar in the insertion position and after the loading returns to its home position the bar measuring device is abnormally activated.
3. During guiding channel closing the bar measuring device is abnormally activated.
4. During bar insertion the bar measuring device is abnormally activated.
5. During bar positioning to TOP CUT the pusher keeps moving forward and exceeds the "TOP CUT" position (Top Cut position + 50mm).
This only applies when feeding with the turret is used ("TOP CUT" = with turret).

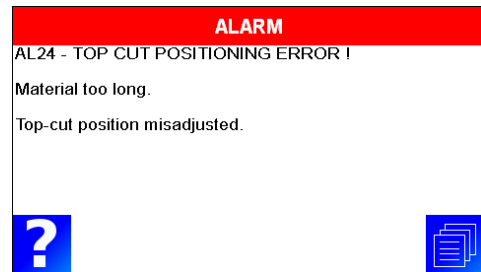

Trouble shooting

1. Check if the "TOP CUT" setup is correct.
 2. Check if the bar measuring device is defective or if SQ1 switch is misadjusted.
 3. Check if the bar measuring device is functioning properly.
 4. Press "STOP" button on HMI to clear the alarm.
- Note: If TOP CUT is positioned without turret stopper change "TOP CUT" setup.

AL26 Bar Feeder Not In AUTO Mode!

Description

To remind the operator that the lathe is possibly in AUTOMATIC mode but the bar feeder is still in MANUAL mode.
The bar feeder is in MANUAL mode when the lathe chuck is opened and closed 3 times without starting the bar feeder in Automatic mode.

Troubleshooting

Switch the bar feeder to AUTOMATIC mode.

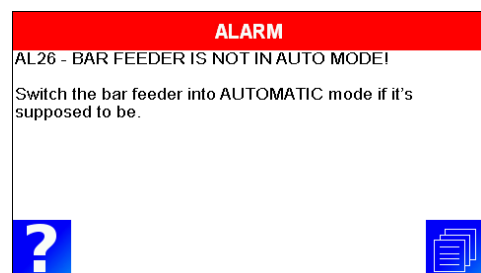

<i>AL30 Booster Clutch Failure During Engagement!</i>	
<p><u>Description</u></p> <p>Before insertion, the booster will connect with pusher by clutch, and move the pusher to extraction position. After finished the movement, PLC will check if the position of pusher is over 40mm. If not, the alarm will arise.</p>	
<p><u>Troubleshooting</u></p> <ol style="list-style-type: none"> 1. Check if booster is broken. 2. Check if there is a problem with pusher. 	
<i>AL34 Loading Motor Failure!</i>	
<p><u>Description</u></p> <p>The loading motor doesn't receive SQ12 signal (OFF to ON) in 5 seconds. This message will arise.</p>	
<p><u>Troubleshooting</u></p> <ol style="list-style-type: none"> 1. Check if SQ12 is broken. 2. Check if the loading motor is malfunction 3. Check if the screws are blocked. 4. Press "STOP" button on remote control to remove the alarm. 	
<i>AL35 Barstock Moving Forward While Chuck Closed!</i>	
<p><u>Description</u></p> <p>During chuck close, bar feeder keeps reading the position of pusher. If the distance of pusher moving forwards is larger than "PART FEEDING: Too long collet closed" setup, the alarm will arise.</p>	
<p><u>Troubleshooting</u></p> <ol style="list-style-type: none"> 1. Check if the bar stock is separated from the pusher collet or if the collet is broken 2. Check if "PART FEEDING" setup is correct 3. Check if the feeding mechanism is malfunction or if the chain is broken. 4. Check if the lathe chuck is malfunctioning or the clamping force setup is incorrect. 5. Press "STOP" button on HMI to clear the alarm. 	

AL36 NC Alarm!	
<p>Description</p> <p>Barfeed receives the alarm message from lathe during Auto mode.</p>	<div style="border: 1px solid black; padding: 5px;"> <div style="background-color: red; color: white; text-align: center; padding: 2px;">ALARM</div> <p>AL36 - NC Alarm!</p> <p>Check if <PI45> setup is incorrect.</p> <p>Check if <PI49> setup is incorrect.</p> <p>Check the wiring of the NC Alarm signal A2.</p> <div style="display: flex; justify-content: space-between; align-items: center;"> ? </div> </div>
<p>Troubleshooting</p> <p>Please check the following setting and signal.</p> <ol style="list-style-type: none"> 1. INTERFACE45: A2 signal logic setup. 2. INTERFACE49: A2 signal definition. 3. Interface cable A2 	

AL37 Servo Drive Alarm	
<p>Description</p> <p>Servo motor or amplifier malfunction</p>	<div style="border: 1px solid black; padding: 5px;"> <div style="background-color: red; color: white; text-align: center; padding: 2px;">ALARM</div> <p>AL37 - SERVO DRIVE ALARM I</p> <p>Please refer to the troubleshooting manual chapter: "amplifier alarms"</p> <div style="display: flex; justify-content: space-between; align-items: center;"> ? </div> </div>
<p>Trouble shooting</p> <ol style="list-style-type: none"> 1. Open the electric cabinet. Check the error code shown on the servo amplifier 2. Follow the trouble shooting guide to solve the problem or contact us for technical support. 3. Press "STOP" button on HMI to clear the alarm. 	

AL38 Motor Lost Its Reference Point!	
<p>Description</p> <ol style="list-style-type: none"> 1. If the pusher home position switch SQ2 is ON but the current position of pusher is off more than 20mm this alarm will be generated. 2. If pusher is at home position (-1.00mm<current position<1.00mm) but switch SQ2 is OFF this alarm will be generated. 	<div style="border: 1px solid black; padding: 5px;"> <div style="background-color: red; color: white; text-align: center; padding: 2px;">ALARM</div> <p>AL38 - MOTOR LOOSE THE REFERENCE POINT</p> <p>Check if the servo motor is broken.</p> <p>Check if SQ2 is broken.</p> <div style="display: flex; justify-content: space-between; align-items: center;"> ? </div> </div>
<p>Troubleshooting</p> <ol style="list-style-type: none"> 1. Check if the servo motor is defective. 2. Check if switch SQ2 is defective of misadjusted. 3. Press "STOP" button on HMI to clear the alarm and press backward to bring the pusher to its home position. 	

AL39 Servo motor positioning error!**Description**

The Servo motor positioning alarm occurs whenever the motor encounters some unexpected resistance.

Solutions

1. Check if the analog module 02DA-E2 is defective.
2. Check for loose wiring connection between the analog module and PCB.
3. Check if the servo amplifier and motor are malfunctioning.
4. Check if the encoder of servo motor is functional.
5. Check if the LED of encoder input on PLC is flickering.
6. Press "STOP" button on HMI to clear the alarm.

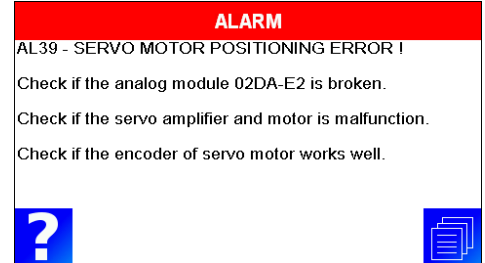

9.4 SERVO AMPLIFIER ERROR MESSAGES

If a fault is detected on the servo drive or motor a corresponding fault code will be shown on the drive's LED display.

9.4.1 Fault Messages Table

Display	Fault Name	Fault Description
AL001	Overcurrent	Main circuit current is higher than 1.5 multiple of motor's instantaneous maximum current value.
AL002	Overvoltage	Main circuit voltage has exceeded its maximum allowable value.
AL003	Undervoltage	Main circuit voltage is below its minimum specified value.
AL004	Motor error	The motor does not match the drive. They are not correctly matched for size (power rating).
AL005	Regeneration error	Regeneration control operation is in error.
AL006	Overload	Servo motor and drive is overload.
AL007	Overspeed	Motor's control speed exceeds the limit of normal speed.
AL008	Abnormal pulse control command	Input frequency of pulse command exceeds the limit of its allowable setting value.
AL009	Excessive deviation	Position control deviation value exceeds the limit of its allowable setting value.
AL010	Reserve	Reserve
AL011	Encoder error	Pulse signal is in error.
AL012	Adjustment error	Adjusted value exceeds the limit of its allowable setting value when perform electrical adjustment.
AL013	Emergency stop activated	Emergency stop switch is activated.
AL014	Reverse limit switch error	Reverse limit switch is activated.
AL015	Forward limit switch error	Forward limit switch is activated.
AL016	IGBT temperature error	The temperature of IGBT is over high.
AL017	Memory error	EE-PROM write-in and read-out is in error.
AL018	Encoder output error	The encoder output exceeds the rated output frequency.
AL019	Serial communication error	RS232/485 communication is in error.
AL020	Serial communication time out	RS232/485 communication time out.
AL021	Reserve	Reserve

Display	Fault Name	Fault Description
AL022	Input power phase loss	One phase of the input power is loss.
AL023	Pre-overload warning	To warn that the servo motor and drive is going to overload. This alarm will display before ALM06. When the servo motor reach the setting value of P1-56, the motor will send a warning to the drive. After the drive has detected the warning, the DO signal OLW will be activated and this fault message will display.
AL024	Encoder initial magnetic field error	The magnetic field of the encoder U, V, W signal is in error.
AL025	Encoder internal error	The internal memory of the encoder is in error. An internal counter error is detected.
AL026	Encoder data error	An encoder data error is detected for three times.
AL027	Motor internal error	The setting value of the encoder is in error.
AL028	Motor internal error	The encoder U, V, W signals are in error.
AL029	Motor internal error	The internal address of the encoder is in error.
AL030	Motor protection error	In order to protect the motor, this alarm will be activated when the setting value of P1-57 is reached after a period of time set by P1-58.
AL031	U,V,W, GND wiring error	The wiring connections of U, V, W (for servo motor output) and GND (for grounding) are in error.
AL035	Motor temperature error	Motor is working under temperature over 105°C (221°F).
AL048	Excessive encoder output error	The encoder output errors or output pulses exceed hardware tolerance.
AL067	Motor temperature warning	The temperature of motor is over 85°C (185°F).
AL099	DSP firmware upgrade	EE-PROM is not reset after the firmware version is upgraded. This fault can be cleared after setting P2-08 to 30 first, and then setting P2-08 to 28 next and restarting the servo drive.

9.4.2 Alarms cause and solutions

AL001	Overcurrent	
Clearing Method	Turn OFF the power supply and restart the servo drive.	
Potential Cause	Checking Method	Corrective Actions
Short-circuit at drive output (U, V, W)	<ol style="list-style-type: none"> 1. Check the wiring connections between drive and motor. 2. Check if the wire is short-circuited. 	Repair the short-circuited and avoid metal conductor being exposed.
Motor wiring error	Check if the wiring steps are all correct when connecting motor to drive.	Follow the wiring steps in the user manual to reconnect wiring.
IGBT error	Heat sink overheated	Please contact your distributor for assistance or contact with Delta.
Control parameter setting error	Check if the setting value exceeds the factory default setting.	Set the setting back to factory default setting and then reset and adjust the parameter setting again.
Control command setting error	Check if the control input command is unstable (too much fluctuation).	<ol style="list-style-type: none"> 1. Ensure that input command frequency is stable (too much fluctuation). 2. Activate filter function.

AL002	Overvoltage	
Clearing Method	Turn OFF the power supply and restart the servo drive.	
Potential Cause	Checking Method	Corrective Actions
The main circuit voltage has exceeded its maximum allowable value.	Use voltmeter to check whether the input voltage falls within the rated input voltage.	Use correct power supply or stabilizing power.
Input power error (Incorrect power input)	Use voltmeter to check whether the input voltage is within the specified limit.	Use correct power supply or stabilizing power.

AL003	Under voltage	
Clearing Method	This fault message can be removed automatically after the voltage has returned within its specification.	
Potential Cause	Checking Method	Corrective Actions
The main circuit voltage is below its minimum specified value.	Check whether the wiring of main circuit input voltage is normal.	Reconfirm voltage wiring.
No input voltage at main circuit.	Use voltmeter to check whether input voltage at main circuit is normal.	Reconfirm power switch.
Input power error (Incorrect power input)	Use voltmeter to check whether the input voltage is within the specified limit.	Use correct power supply or serial stabilizing power.

AL004	Motor error	
Clearing Method	Turn OFF the power supply and restart the servo drive.	
Potential Cause	Checking Method	Corrective Actions
Encoder is damage.	Check Encoder for the damage.	Repair or replace the motor.
Encoder is loose.	Examine the Encoder connector.	Install the motor again.
The type of the servo motor is incorrect.	Check if the servo drive and servo motor are not correctly matched for size power rating.	Replace the motor.

AL005	Regeneration error	
Clearing Method	Turn OFF the power supply and restart the servo drive.	
Potential Cause	Checking Method	Corrective Actions
Regenerative resistor is not connected.	Check the wiring connection of regenerative resistor.	Reconnect regenerative resistor.
Regenerative switch transistor fault	Check if regenerative switch transistor is short-circuited.	Please contact your distributor for assistance or contact with Delta.
Parameter setting is in error	Confirm the parameter setting and specifications of regenerative resistor.	Correctly reset parameter again.

AL006	Overload	
Clearing Method	Turn OFF the power supply and restart the servo drive.	
Potential Cause	Checking Method	Corrective Actions
The drive has exceeded its rated load during continuous operation.	Check if the drive is overloaded.	Increase motor capacity or reduce load.
Control system parameter setting is incorrect.	Check if there is mechanical vibration	Adjust gain value of control circuit.
	Accel/Decel time setting is too fast.	Decrease Accel/Decel time setting.
The wiring of drive and encoder is in error.	Check the wiring of U, V, W and encoder.	Ensure all wiring is correct.

AL007	Overspeed	
Clearing Method	Turn OFF the power supply and restart the servo drive.	
Potential Cause	Checking Method	Corrective Actions
Speed input command is not stable (too much fluctuation).	Use signal detector to detect if input signal is abnormal.	Ensure that input command frequency is stable (not fluctuate too much) and activate filter function (P1-06, P1-07 and
Over-speed parameter setting is defective.	Check if over-speed parameter setting value is too low.	Correctly set over-speed parameter setting (P2-34).

AL008	Abnormal pulse control command	
Clearing Method	Turn OFF the power supply and restart the servo drive.	
Potential Cause	Checking Method	Corrective Actions
Pulse command frequency is higher than rated	Use pulse frequency detector to measure input frequency.	Correctly set the input pulse frequency.

AL009	Excessive deviation	
Clearing Method	Turn OFF the power supply and restart the servo drive.	
Potential Cause	Checking Method	Corrective Actions
Maximum deviation parameter setting is too small.	Check the maximum deviation parameter setting and observe the position error value when the motor is running.	Increases the parameter setting value of P2-35.
Gain value is too small.	Check for proper gain value.	Correctly adjust gain value.
Torque limit is too low.	Check torque limit value.	Correctly adjust torque limit value.
There is an overload.	Check for overload condition.	Reduce external applied load or re-estimate the motor capacity.

AL010	Reserve	
-------	---------	--

AL011	Encoder error (Position detector fault)	
Clearing Method	Turn OFF the power supply and restart the servo drive.	
Potential Cause	Checking Method	Corrective Actions
The wiring of encoder is in error.	1. Check if all wiring is correct. 2. Check if the users conduct the wiring by the wiring information in the user manual.	Ensure all wiring is correct.
Encoder is loose	Examine the encoder connector.	Install the motor again.
The wiring of encoder is	Check if all connections are tight.	Conduct the wiring again.
Encoder is damage	Check the encoder for the damage.	Repair or replace the motor.

AL012	Adjustment error	
Clearing Method	Turn OFF the power supply and restart the servo drive.	
Potential Cause	Checking Method	Corrective Actions
The setting value of drift adjustment has exceeded its maximum allowable value.	1. Remove CN1 wiring. 2. Execute the drift adjustment again. (Set P2-08 to 20 first, and then set P4-10 to 5.)	If the error does not clear after executing the drift adjustment again, please contact your distributor for assistance or contact with Delta.

AL013	Emergency stop activated	
Clearing Method	Turn OFF the power supply and restart the servo drive.	
Potential Cause	Checking Method	Corrective Actions
Emergency stop switch is activated.	Check if emergency stop switch is On or Off.	Activate emergency stop switch.

AL014	Reverse (CWL) limit switch error	
Clearing Method	Turn OFF the power supply and restart the servo drive.	
Potential Cause	Checking Method	Corrective Actions
Reverse limit switch is activated.	Check if reverse limit switch is On or Off.	Activate reverse limit switch.
Servo system is not stable.	Check the value of control parameter setting and load inertia.	Modify parameter setting and re-estimate motor capacity.

AL015	Forward (CCWL) limit switch error	
Clearing Method	Turn OFF the power supply and restart the servo drive.	
Potential Cause	Checking Method	Corrective Actions
Forward limit switch is activated.	Check if forward limit switch is On or Off.	Activate forward limit switch.
Servo system is not stable.	Check the value of control parameter setting and load inertia.	Modify parameter setting and re-estimate motor capacity.

AL016	IGBT temperature error	
Clearing Method	Turn OFF the power supply and restart the servo drive.	
Potential Cause	Checking Method	Corrective Actions
The drive has exceeded its rated load during	Check if there is overload or the motor current is too high.	Increase motor capacity or reduce load.
Short-circuit at drive output.	Check the drive input wiring.	Ensure all wiring is correct.

AL017	Memory error	
Clearing Method	Turn OFF the power supply and restart the servo drive.	
Potential Cause	Checking Method	Corrective Actions
Parameter data error when writing into EE-PROM.	<p>Examine the parameter settings. Please do the following steps:</p> <ol style="list-style-type: none"> 1. Press SHIFT key on the drive keypad, and examine the parameter shown on LED display. 2. If E320A is displayed (in hexadecimal format), it indicates it is parameter P2-10. Please examine the parameter settings of P2-10. 3. If E3610 is displayed (in hexadecimal format), it indicates it is parameter P6-16. Please examine the parameter settings of P6-16. 	<ol style="list-style-type: none"> 1. If this fault occurs when power is applied to the drive, it indicates that the setting value of one parameter has exceeded the specified range. Correct the setting value of the parameter to clear the fault and restart the servo drive. 2. If this fault occurs during normal operation, it indicates that the error occurs when writing data into EE-PROM. Turn ARST (DI signal) ON to clear the fault or restart the servo
The setting value of hidden parameter is in error.	Press SHIFT key on the drive keypad and examine if E100X is displayed on LED display.	If this fault occurs when resetting the parameter settings, it indicates that the servo drive type is not set correctly. Correctly set the servo drive type again.
Data in EE-PROM is damaged.	Press SHIFT key on the drive keypad and examine if E0001 is displayed on LED display.	If this fault occurs when power is applied to the drive, it indicates that the data in EE-RPM is damaged or there is no data in EE-PROM. Please contact your distributor for assistance or contact with Delta.

AL018	Encoder output error	
Clearing Method	Turn OFF the power supply and restart the servo drive.	
Potential Cause	Checking Method	Corrective Actions
Encoder itself or the wiring of encoder is in error.	Check if the recent fault records (P4-00 ~ P4-05) display on the drive keypad in accordance with the fault codes AL011, AL024, AL025 and AL026.	Perform the corrective actions as described in AL011, AL024, AL025 and AL026.
The output frequency for pulse output may exceed the limit of its allowable setting value.	Check if the following conditions occur: Condition 1: Motor speed is above the value set by P1-76. Condition 2: $\frac{\text{Motor Speed}}{60} \times P1-46 \times 4 > 19.8 \times 10^6$	Correctly set P1-76 and P1-46. 1. Ensure that the motor speed is below the value set by P1-76. 2. $\frac{\text{Motor Speed}}{60} \times P1-46 \times 4 > 19.8 \times 10^6$

AL019	Serial communication error	
Clearing Method	Turn OFF the power supply and restart the servo drive.	
Potential Cause	Checking Method	Corrective Actions
Communication parameter setting	Check the communication parameter setting.	Correctly set parameter setting.
Communication address is incorrect.	Check the communication address.	Correctly set communication address.
Communication value is incorrect.	Check the communication value.	Correctly set communication value.

AL020	Serial communication time out	
Clearing Method	Turn OFF the power supply and restart the servo drive.	
Potential Cause	Checking Method	Corrective Actions
Setting value in time out parameter	Check communication time out parameter setting.	Correctly set P3-07.
Not receiving communication command for a long time.	Check whether communication cable is loose or broken.	Tighten the communication cable, make sure the communication cable is not damaged and ensure all wiring is correct.

AL021	Reserve	
AL022	Input power phase loss	
Clearing Method	Turn OFF the power supply and restart the servo drive.	
Potential Cause	Checking Method	Corrective Actions
Control power supply is in error.	Check the power cable and connections of R, S, and T. Check whether the power cable is loose or the possible loss of phase on input power.	If the fault does not clear even when the three-phase power is connected correctly, please contact your distributor for assistance or contact with Delta.
AL023	Pre-overload warning	
Clearing Method	Turn OFF the power supply and restart the servo drive.	
Potential Cause	Checking Method	Corrective Actions
The drive is going to overload.	<ol style="list-style-type: none"> 1. Check the load condition of the servo motor and drive. 2. Check the setting value of P1-56. Check whether the setting value of P1-56 is too small. 	<ol style="list-style-type: none"> 1. Please refer to the correction actions of ALE06. 2. Increase the setting value of P1-56 or set P1-56 to 100 and above.
AL024	Encoder initial magnetic field error	
Clearing Method	Turn OFF the power supply and restart the servo drive.	
Potential Cause	Checking Method	Corrective Actions
The magnetic field of the encoder U, V, W signal is in error.	<ol style="list-style-type: none"> 1. Check if the servo motor is properly grounded. 2. Check if the encoder signal cables are placed in separate conduits from the cables connected to R, S, T and U, V, W terminals to prevent the interference. 3. Check if the shielded cables are used when performing encoder wiring. 	If the error does not clear after each checking is done, please contact your distributor for assistance or contact with Delta.

AL025	Encoder internal error	
Clearing Method	Turn OFF the power supply and restart the servo drive.	
Potential Cause	Checking Method	Corrective Actions
The internal memory of the encoder is in error. An encoder counter error occurs.	<ol style="list-style-type: none"> 1. Check if the servo motor is properly grounded. 2. Check if the encoder signal cables are placed in separate conduits from the cables connected to R, S, T and U, V, W terminals to prevent the interference. 3. Check if the shielded cables are used when performing encoder wiring. 	<ol style="list-style-type: none"> 1. Please connect the grounding (green color) of U, V, W terminal to the heat sink of the servo drive. 2. Ensure that the encoder signal cables are placed in separate conduits from the cables connected to R, S, T and U, V, W terminals to prevent the interference. 3. Please use shielded cables for Encoder wiring. 4. If the error does not clear after all the above actions are done, please contact your distributor for assistance or contact with Delta.

AL026	Encoder data error	
Clearing Method	Turn OFF the power supply and restart the servo drive.	
Potential Cause	Checking Method	Corrective Actions
An encoder data error occurs for three times.	<ol style="list-style-type: none"> 1. Check if the servo motor is properly grounded. 2. Check if the encoder signal cables are placed in separate conduits from the cables connected to R, S, T and U, V, W terminals to prevent the interference. 3. Check if the shielded cables are used when performing encoder wiring. 	<ol style="list-style-type: none"> 1. Please connect the grounding (green color) of U, V, W terminal to the heat sink of the servo drive. 2. Ensure that the encoder signal cables are placed in separate conduits from the cables connected to R, S, T and U, V, W terminals to prevent the interference. 3. Please use shielded cables for Encoder wiring. 4. If the error does not clear after all the above actions are done, please contact your distributor for assistance or contact with Delta.

AL027	Motor internal error	
Clearing Method	Turn OFF the power supply and restart the servo drive.	
Potential Cause	Checking Method	Corrective Actions
The setting value of the encoder is in error.	<ol style="list-style-type: none"> 1. Check if the servo motor is properly grounded. 2. Check if the encoder signal cables are placed in separate conduits from the cables connected to R, S, T and U, V, W terminals to prevent the interference. 3. Check if the shielded cables are used when performing encoder wiring. 	<ol style="list-style-type: none"> 1. Please connect the grounding (green color) of U, V, W terminal to the heat sink of the servo drive. 2. Ensure that the encoder signal cables are placed in separate conduits from the cables connected to R, S, T and U, V, W terminals to prevent the interference. 3. Please use shielded cables for Encoder wiring. 4. If the error does not clear after all the above actions are done, please contact your distributor for assistance or contact with Delta.

AL028	Motor internal error	
Clearing Method	Turn OFF the power supply and restart the servo drive.	
Potential Cause	Checking Method	Corrective Actions
The encoder U, V, W signals are in error.	<ol style="list-style-type: none"> 1. Check if the servo motor is properly grounded. 2. Check if the encoder signal cables are placed in separate conduits from the cables connected to R, S, T and U, V, W terminals to prevent the interference. 3. Check if the shielded cables are used when performing encoder wiring. 	<ol style="list-style-type: none"> 1. Please connect the grounding (green color) of U, V, W terminal to the heat sink of the servo drive. 2. Ensure that the encoder signal cables are placed in separate conduits from the cables connected to R, S, T and U, V, W terminals to prevent the interference. 3. Please use shielded cables for Encoder wiring. 4. If the error does not clear after all the above actions are done, please contact your distributor for assistance or contact with Delta.

AL029	Motor internal error	
Clearing Method	Turn OFF the power supply and restart the servo drive.	
Potential Cause	Checking Method	Corrective Actions
The internal address of the encoder is in error.	<ol style="list-style-type: none"> 1. Check if the servo motor is properly grounded. 2. Check if the encoder signal cables are placed in separate conduits from the cables connected to R, S, T and U, V, W terminals to prevent the interference. 3. Check if the shielded cables are used when performing encoder wiring. 	<ol style="list-style-type: none"> 1. Please connect the grounding (green color) of U, V, W terminal to the heat sink of the servo drive. 2. Ensure that the encoder signal cables are placed in separate conduits from the cables connected to R, S, T and U, V, W terminals to prevent the interference. 3. Please use shielded cables for Encoder wiring. 4. If the error does not clear after all the above actions are done, please contact your distributor for assistance or contact with Delta.

AL030	Motor protection error	
Clearing Method	Turn OFF the power supply and restart the servo drive.	
Potential Cause	Checking Method	Corrective Actions
The setting value of parameter P1-57 is reached after a period of time set by parameter P1-58.	<ol style="list-style-type: none"> 1. Check if P1-57 is enabled. 2. Check if the setting values of P1-57 and P1-58 are both too small. 	<ol style="list-style-type: none"> 1. Set P1-57 to 0. 2. Correctly set P1-57 and P1-58. Please note that the over-low setting may results in malfunction, but over-high setting may let the motor protection function not operate.

AL031	U,V,W, GND wiring	
Clearing Method	Turn OFF the power supply and restart the servo drive.	
Potential Cause	Checking Method	Corrective Actions
The wiring connections of U, V, W (for servo motor output) and GND (for grounding) are in error.	Check if wiring connections of U, V, and W are not correct.	Follow the wiring steps in the user manual to reconnect the wiring and ground the servo drive and motor properly.
The ground connection is loose or not conducting properly.	Check if the ground connection is loose and ensure the ground is conducting properly.	

AL035	Motor temperature	
Clearing Method	Turn OFF the power supply and restart the servo drive.	
Potential Cause	Checking Method	Corrective Actions
Motor is working under temperature over 105°C	Check if the environment temperature is too high.	Try to reduce environment temperature.

AL048	Excessive encoder	
Clearing Method	Turn OFF the power supply and restart the servo drive.	
Potential Cause	Checking Method	Corrective Actions
Encoder error causes abnormal encoder output.	Exam error records (P4-00~P4-05) to check if encoder errors occurred. (AL011, AL024, AL025, AL026)	Please refer to AL011, AL024, AL025, AL026 and take corrective actions.
Output pulses exceed hardware tolerance.	Check if conditions below occur, $P1-76 < \text{Motor rotation speed}$, or $\frac{\text{Motor rotation speed}}{60} \times P1-46 \times 4 > 19.8 \times 10^6$	Correctly set P1-76 and P1-46: $P1-76 > \text{Motor rotation speed}$, and, $\frac{\text{Motor rotation speed}}{60} \times P1-46 \times 4 > 19.8 \times 10^6$

AL067	Motor temperature	
Clearing Method	This fault message can be removed after temperature drops to normal degree.	
Potential Cause	Checking Method	Corrective Actions
Motor is working under temperature over 85°C (185°F).	Check if the environment temperature is too high.	Try to reduce environment temperature.

AL099	DSP firmware	
Clearing Method	Turn OFF the power supply and restart the servo drive.	
Potential Cause	Checking Method	Corrective Actions
EE-PROM is not reset after the firmware version is upgraded.	Check if EE-PROM is reset after the firmware version is upgraded.	Set P2-08 to 30 first, and then 28 next, and restart the servo drive.

9.5 FACTORS AFFECTING PERFORMANCE

9.5.1 Installation

The installation is a very important phase that, if neglected, could seriously impede the operation of the bar feed system.

Distance The distance between the bar feed system and the lathe influences greatly the quality of the guiding. The further the bar feed system is from the spindle - and therefore, away from the clamping system - the larger the non-guided part of the bar will be.

It is essential that the mounting of the bar feed system is done in accordance with the instructions indicated in Chapter 3: Setting into operation.

Alignment The guiding channel of the bar feed system serves, by definition, to guide the bar outside the lathe. Although the bar rotates in an oil bath inside the guiding channel, the alignment of the channel with the axis of the spindle must be perfect.

It is essential that the alignment of the bar feed system is done in accordance with the instructions indicated in Chapter 3: Setting into operation.

Spindle length In some cases, the length of the spindle may influence the quality of the guidance.

9.5.2 Gap between the guiding elements and the bar

The best results are obtained when the bar is guided with precision (3 mm). The greater the reduction of the clearance between the bar and the tube, the greater the rotation speeds will be.

When the clearance between the bar and the tube becomes too great, a rupture of the oil film occurs which results in the reduction of the rotation speeds permitted.

9.5.3 Gap between the spindle and the bar

While the rear of the bar is maintained by front rest of the bar feed system and the front by the collet or the chuck of the lathe, it is possible for the portion of the bar inside the spindle to oscillate, if the clearance is too great.

It is, therefore, highly recommended to install reduction liner inside the spindle as indicated in the start-up manual.

9.5.4 Material

Bars

To obtain a perfect insertion inside the collet of the bar feed system, the bars must be chamfered concentrically (at the rear) at 30° . At the feeding process, it is recommended to deburr the bar at the front, to avoid possible catching during the introduction of the bar inside the spindle.

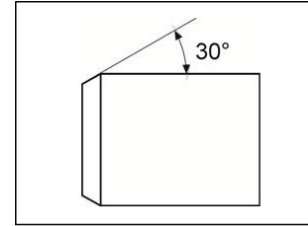

In some cases, when the diameter of the bar is close to the external diameter of the collet (see assembly of pushers), the rear of the bars must be machined to the inside diameter (D) of the collet. The length of the machining (L) must be at least 30mm.

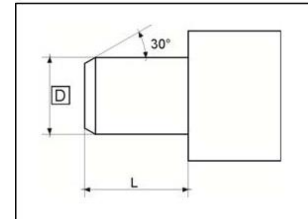

Tubes

To prevent mixing the oil from the feeding process and the cutting oil from the lathe, it is essential to put a plug in the rear of the tubes to be machined.

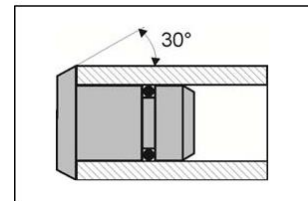

Profiled material

It is recommended to install a bushing, inside the clamping device, with the same inside profile (+ 0.2 mm) as the bar. The back of this bushing must be chamfered.

The rear of the collet and the front of the bars should be flat. During the loading cycle, a slight rotation of the spindle (about 30 RPM) is desirable.

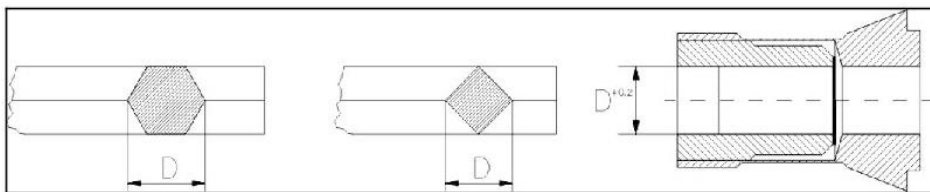

Bars straightness

Performances may vary, depending on the material machined, the length of the bar, etc. To obtain optimum output, the bars must be straight. If the bar straightness exceeds 0.5 mm (.020") per meter (3.25'), non-accumulative, performance will automatically be reduced in regards to speeds of rotation while vibrations will increase accordingly.

In this instance, the quality of the guidance is not the cause.

Material composition

In general, the difficulty increases with the specific weight of the bar. Steel bars are relatively easy to guide.

Because of their great flexibility and specific weight, brass bars are relatively difficult to guide at high speeds. Aluminum bars of aluminum are very easy to guide.

9.6 MAINTENANCE



Please read the safety instructions provided at the beginning of this manual before handling the following devices.

9.6.1 Hydraulics

It is important to clean the bars (even briefly) before loading them on the feed system magazine. Excessive dirt can form a deposit at the base of the bar feed system, which can in turn slow the oil return.

9.6.2 Pneumatics

The air-filtering device is equipped with an automatic drainage valve, making it unnecessary to empty it. The water recuperated comes from the pneumatic circuit of the building. It is advisable to make certain that the air received by the bar feed system is as dry as possible (see Chapter 5 / Pneumatics).

9.6.3 Batteries

In the event of a power failure, a backup battery saves the data contained in the PLC. It is possible that with time this battery will slowly drain; in this case a message will be displayed on the remote control. The battery must be replaced as soon as possible with a battery of the same type. The same applies to the SERVO amplifier.

9.6.4 Mechanics

Rotating sleeves

In order to guarantee the correct operation of the bar feed system, the rotating sleeve must function perfectly. Although the construction of the sleeve is very sturdy and reliable, it is recommended to verify periodically that it rotates without friction. If a defect should be present, please contact your local agent.

Chain

It is possible that after a certain amount of use, the drive needs to be tightened. To tighten the drive, refer to Chapter 7 / Point 6.3.

9.6.5 Cleaning

As with any vehicle, machinery, or device, regular cleaning of your bar feed system can only serve to improve its operation and prolong its useful life.

For cleaning on the outside, use a soft cloth and a regular detergent; for the inside, use a cloth or a brush. However, make sure that the rollers and parts made of synthetic materials do not come into contact with these products.

Use of compressed air for cleaning is not advisable, because particles could become lodged in sensitive areas and impede the proper operation of the bar feed system.



At no time should solvents, such as acetone, or diluents be used for cleaning the bar feed system. At no time should cleaning products come into contact with electrical components.

APPENDIX A: PROGRAMMING EXAMPLE

MAIN PROGRAM

N... "M" CODE "LATHE IN AUTOMATIC CYCLE"

N... SPINDLE STOP

N... COOLANT OFF

N... END OF BAR CHECK (PROGRAM JUMP) >

> TURRET TO FEED IN POSITION

N... COLLET OPEN

N... TURRET TO FEED OUT POSITION

N... END OF BAR CHECK (PROGRAM JUMP) >

N... CLOSE COLLET

N... CLEAR TURRET

N...

PART PROGRAM

N... X, Z, G, F, T, S, M, ...

N... MACHINE PART

N... PARTS CATCHER IN (IF AVAILABLE)

N... CUT OFF

N... PARTS CATCHER OFF (IF AVAILABLE)

N...

N...

N... X, Z, G, F, T, S, M, ...

N...

N... END OF PROGRAM (LOOP)

SUB-PROGRAM

N... TURRET HOME

... "M"CODE (DWELL/LOAD)

N... CLOSE COLLET

N... START SPINDLE

N... COLLANT ON

N... TOP CUT MATERIAL

N...

N...

N... END OF SUB-PROGRAM

< **(RETURN TO MAIN PROGRAM)**

Important: The above is an example only. Programming may change according to the application.

APPENDIX B: ORDERING FORM

This form should be photocopied, duly filled out, and sent to LNS or to your nearest LNS Representative/Agent

Company name:

Person in charge:

Address:

ZIP: City:

Country:

Phone:

Fax:

Type of device:

Serial number:

Qty.	Ordering no.	Description

Expected delivery:

Location and date:

Signature and stamp of the company:

APPENDIX C: ADDRESS LNS

LNS Japan : www.lns-japan.com

油槽組 (Case set)
 △ B Standard stand : XM1.06.A505B
 △ B Retraction : XM1.06.A503B

腳座組 (Stand set)
 Standard stand : XA1.01.A001A
 LNS type stand : XA1.01.A005A
 XT320 type : XA1.01.A006A

△ B = 5

Item	Qty.	Part No.	Descr.
1	1	XM1.03.A501B	
2	1	XM1.05.A307A	
3	1	XM1.05.A501A	
4	1	XM1.08.A501A	
5	3	XM1.08.P012B.02	
6	3	XM1.08.P013A	
7	1	XM1.09.A001A	
8	1	XM1.13.A001A	
9	1	XM1.13.A004A	
10	1	XM1.14.A005A	
11	6	XM1.14.A007B	
12	2	XM1.14.A008B	
13	1	XM1.14.A013A	
14	1	XM1.14.A501A	
15	1	XM1.14.P039A	
16	1	XM1.21.A001A	
17	1	XM1.22.A001B	
18	1	XM1.22.A003A	
19	1	XM1.22.A004A	
△ B 20	1	XM1.27.A002A	
△ B 21	1	XM1.27.A501B	

DESCRIPTION : 基本機 - 12' - 右 / basic machine - 12' - LtoRF				SCALE	1:17	
GT 112-E Basic Machine				MATERIAL		
				SURFACE		
				HARDNESS		
				WEIGHT (Kg)		
				DATE	2016.01.18	2017.06.02
				DRAWN BY	林義碧	Last modif.
				ECN	ECN.XM1.058	
				XM1.00.A501B		

GENERAL TOLERANCE							
1 - 4	± 0.05	± 0.1	17 - 63	± 0.1	± 0.3	251 - 1000	± 0.3 ± 0.8
5 - 16	± 0.07	± 0.2	64 - 250	± 0.2	± 0.5	>1001	± 0.8 ± 1

Our drawings/designs and their annexes remain our sole property and we confide them to the addressee's personal care. Nobody has the right-without our written authorization-to copy, reproduce, show or give them to third parties in收件人个人需求下, 我们透露我们的设计图面与它的附件, 但它们仍然是我们专属的财产。任何人无权在未取得我们的书面文字授权的情况下复制、再制、展示和提供它们给第三者。

LNS GROUP www.lns-group.com TW

Item	Qty.	Part No.	Descr.
1	2	052.010.024	
2	1	XM1.01.A002C	
3	2	XM1.01.A003B	

B2

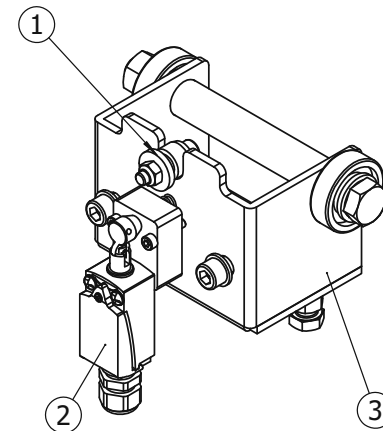
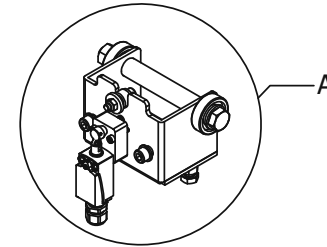

A (1 : 4)

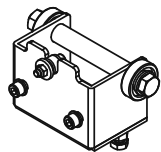

$\triangle B2 = 1$

DESCRIPTION : 腳座 CE - 滑輪組 / stand CE - pulley

SCALE **1:8**

GT 112-E Stand

MATERIAL

SURFACE

HARDNESS

WEIGHT (Kg)

DATE

2014.06.25

2015.12.30

DRAWN BY

Adam Li

Last modif.

ECN

ECN.020.032

B2

XM1.01.A001B

GENERAL TOLERANCE

1 - 4	± 0.05	± 0.1	17 - 63	± 0.1	± 0.3	251 - 1000	± 0.3	± 0.8
5 - 16	± 0.07	± 0.2	64 - 250	± 0.2	± 0.5	>1001	± 0.8	± 1

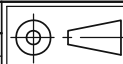

Our drawings/designs and their annexes remain our sole property and we confide them to the addressee's personal care. Nobody has the right without our written authorization to copy, reproduce, show or give them to third parties. 在收件人个人需求下, 我们透露我们的设计图面与它的附件, 但它们仍然是我们专属的财产。任何人无权在未获得我们的书面文字授权的情况下复制、再制、展示和提供它们给第三者。



www.lns-group.com

TW

Item	Qty.	Part No.	Descr.
1	1	XM1.01.A004A	
2	4	XA1.01.P019A	
3	1	XM1.01.A001B	
4	8	Washer DIN 125 - A 6.4	
5	8	DIN 912 M6 x 30	
6	1	Spring Pin 5x12	

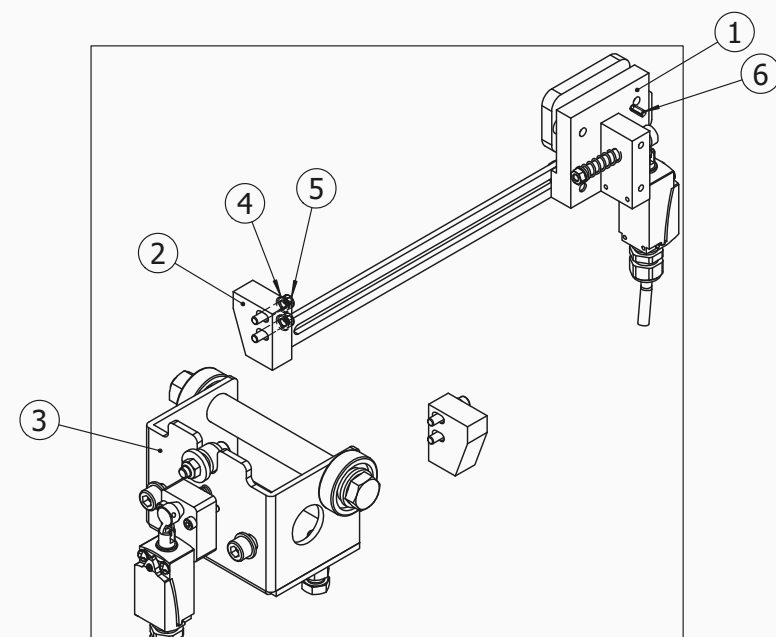
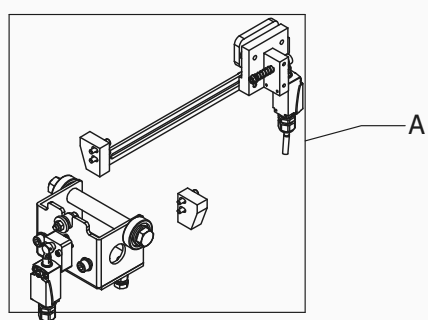
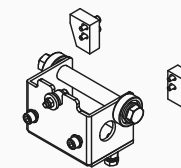

A (1 : 5)

DESCRIPTION : 腳座 CE - 滑輪組 / stand CE - pulley		SCALE	1:8
<h1>GT 112-E</h1> <h2>Stand</h2>		MATERIAL	
		SURFACE	
		HARDNESS	
		WEIGHT (Kg)	
		DATE	2016.9.19
		DRAWN BY	李曙君 Last modif.
		ECN	ECN.XM1.044 A0
		XM1.01.A005A	

GENERAL TOLERANCE

1 - 4	± 0.05	± 0.1	17 - 63	± 0.1	± 0.3	251 - 1000	± 0.3	± 0.8
5 - 16	± 0.07	± 0.2	64 - 250	± 0.2	± 0.5	>1001	± 0.8	± 1

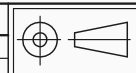

Our drawings/designs and their annexes remain our sole property and we confide them to the addressee's personal care. Nobody has the right without our written authorization to copy, reproduce, show or give them to third parties in收件人个人需求下, 我们透露我们的设计图面与它的附件, 但它们仍然是我们专属的财产。任何人无权在未获得我们的书面授权的情况下复制、再制、展示和提供它们给第三者。



www.lns-group.com

TW

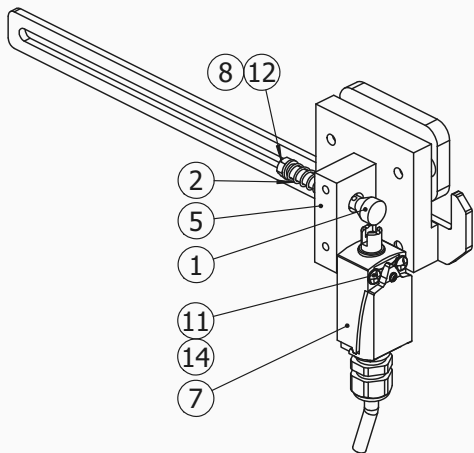
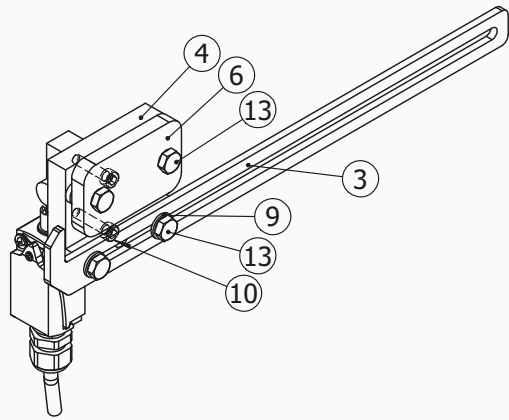

LtoRF

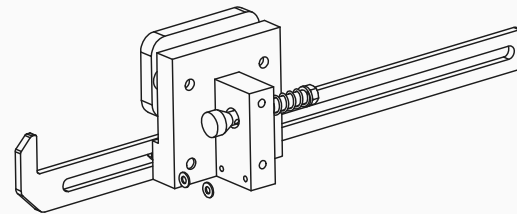
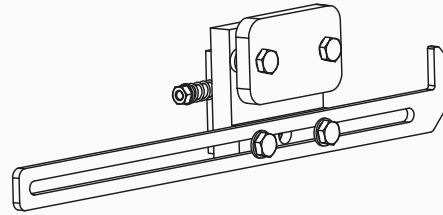

RtoLF

Item	Qty.	Part No.	Descr.
1	1	028.21.594D	
2	1	11.4454	
3	1	XA1.01.P017A	
4	1	XA1.01.P018A	
5	1	XA1.01.P020A	
6	1	XA1.01.P021A	
7	1	XM1.78.A041A	
8	1	125A.06.Z	
9	2	125A.8.Z	
10	2	DIN912 M6x25_ELEC	
11	2	M4x30--One-way bolt_ELEC	
12	1	Nut_DIN 934 M6-W_ELEC	
13	4	OUT Hex JIS M8x25_ELEC	
14	2	Washer DIN 125 - A 4.3	

DESCRIPTION : CE調整開關組/ Adjustable Stoppage

SCALE 1:4

GT 112-E Stand

MATERIAL

SURFACE

HARDNESS

WEIGHT (Kg)

DATE

2016.9.19

DRAWN BY

李曙君

Last modif.

ECN

ECN.XM1.044

A0

XM1.01.A004A

GENERAL TOLERANCE

1 - 4	± 0.05	± 0.1	17 - 63	± 0.1	± 0.3	251 - 1000	± 0.3	± 0.8
5 - 16	± 0.07	± 0.2	64 - 250	± 0.2	± 0.5	>1001	± 0.8	± 1

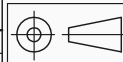

Our drawings/designs and their annexes remain our sole property and we confide them to the addressee's personal care. Nobody has the right without our written authorization to copy, reproduce, show or give them to third parties in person or by any means, electronic or mechanical, including photocopying, recording, or by any information storage and retrieval system. 在收件人个人需求下，我们透露我们的设计图面与它的附件，但它们仍然是我们专属的财产。任何人无权在未获得我们的书面文字授权的情况下复制、再制、展示和提供它们给第三者。



www.lns-group.com

TW

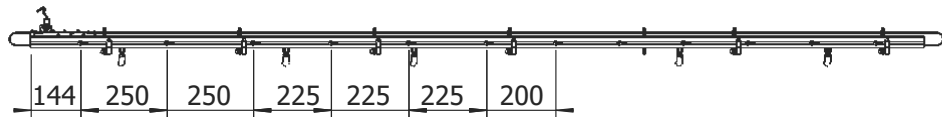

右向 - LtoRF
XM1.03.A201C

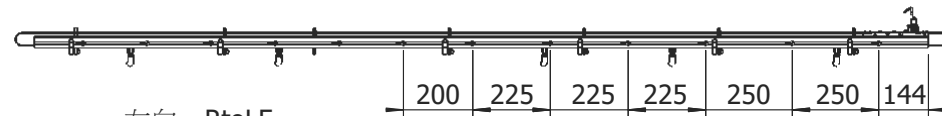

左向 - RtoLF
XM1.03.A202C

長押棒時，組件XM1.03.A003A組裝位置於前。
短押棒時，組裝位置與XM1.03.A001A對調

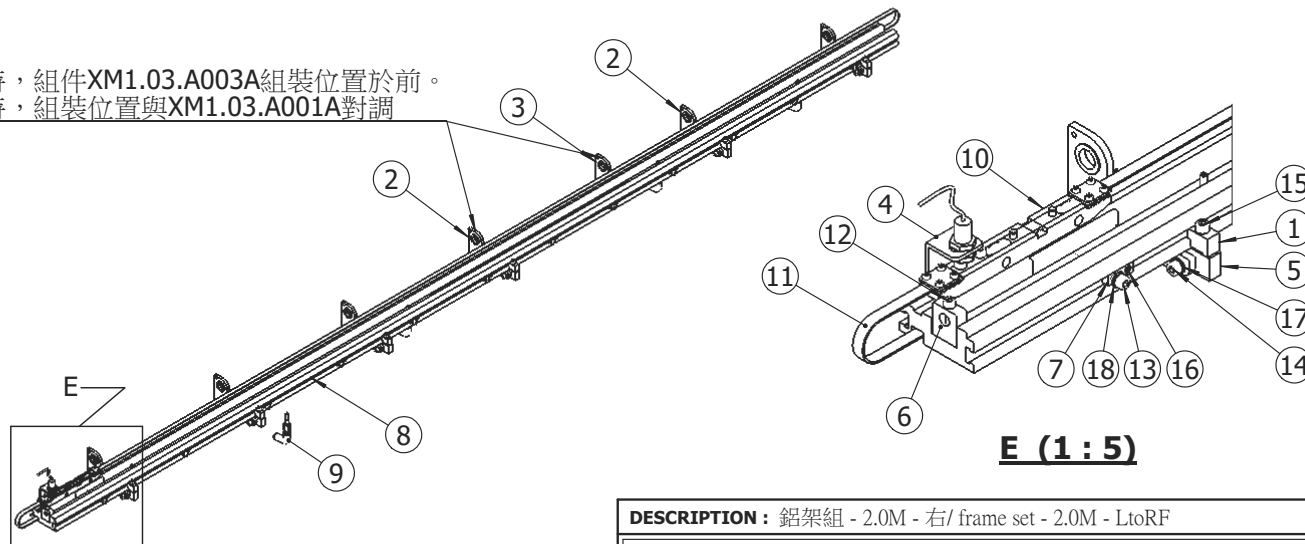

△C1

△C1

Item	Qty.	Part No.	Descr.
1	12	XH13105000000	
2	6	XM1.03.A001A	右-LtoRF
2	6	XM1.03.A002A	左-RtoLF
3	1	XM1.03.A003A	右-LtoRF
3	1	XM1.03.A004A	左-RtoLF
4	1	XM1.03.A005A	
5	6	XM1.03.P004A	
6	1	XM1.03.P009B	
7	12	XM1.03.P012A	
8	1	XM1.03.P201C	右-LtoRF
8	1	XM1.03.P202C	左-RtoLF
9	5	XM1.09.A005A	
10	1	XM1.13.A003A	
11	1	XM1.13.P201A	
12	1	DIN 912 M5 x 35	
13	12	DIN 912 M6 x 12	
14	12	DIN 912 M6 x 20	
15	12	DIN 912 M6 x 25	
16	12	DIN 913 - M6 x 8	
17	12	Spring Washer_JIS_6	
18	12	Washer DIN 125 - A 6.4	

△C1 = 2

E (1:5)

DESCRIPTION : 鋁架組 - 2.0M - 右/ frame set - 2.0M - LtoRF

GT 112-E

Guiding Modules

SCALE **1:15**

MATERIAL

SURFACE

HARDNESS

WEIGHT (Kg)

DATE 2014.06.25 2017.07.12

DRAWN BY 林義碧 Last modif.

ECN ECN.XM1.066 C1

XM1.03.A201C

GENERAL TOLERANCE					
1 - 4	± 0.05	± 0.1	17 - 63	± 0.2	± 0.3
5 - 16	± 0.07	± 0.2	64 - 250	± 0.2	± 0.5
			251 - 1000	± 0.3	± 0.8
			>1001	± 0.8	± 1

Our drawings/designs and their annexes remain our sole property and we confide them to the addressee's personal care. Nobody has the right without our written authorization to copy, reproduce, show or give them to third parties. 在收件人个人需求下，我们透露我们的设计图面与它的附件，但它们仍然是我们专属的财产。任何人无权在未取得我们的书面授权的情况下复制、再制、展示和提供它们给第三者。



www.lns-group.com

TW



右向 - LtoRF

XM1.03.A501B



左向 - RtoLF

XM1.03.A502B

長押棒時，組件XM1.03.A003A組裝位置於前。
短押棒時，組裝位置與XM1.03.A001A對調

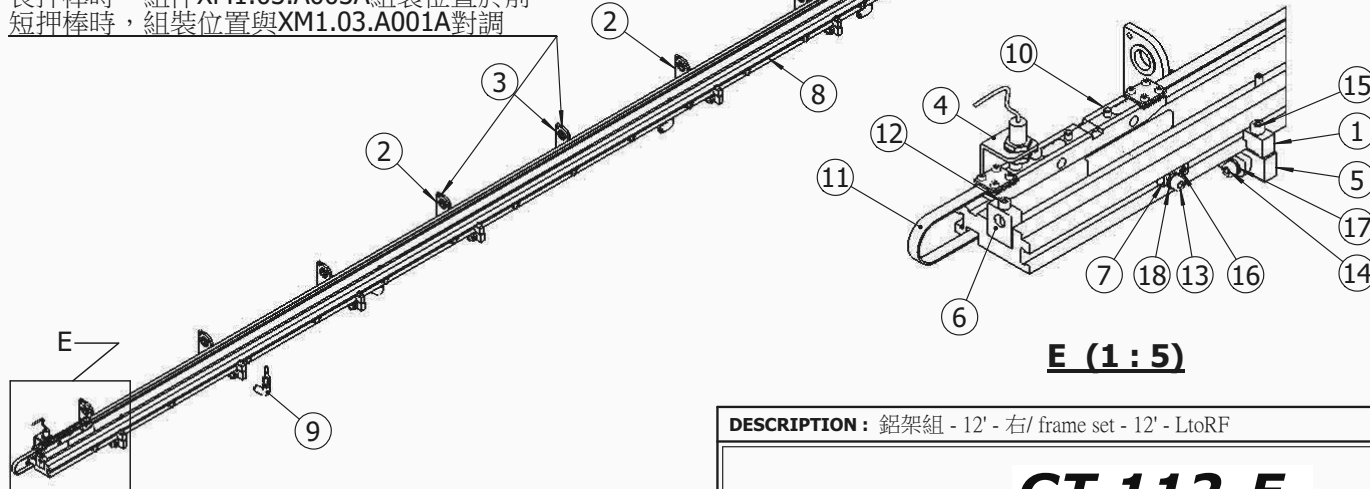

E (1:5)

B1 = 2

Item	Qty.	Part No.	Descr.
1	20	XH13105000000	
2	10	XM1.03.A001A	右 - LtoRF
2	10	XM1.03.A002A	左 - RtoLF
3	1	XM1.03.A003A	右 - LtoRF
3	1	XM1.03.A004A	左 - RtoLF
4	1	XM1.03.A005A	
5	10	XM1.03.P004A	
6	1	XM1.03.P009B	
7	21	XM1.03.P012A	
8	1	XM1.03.P501B	右 - LtoRF
8	1	XM1.03.P502B	左 - RtoLF
9	7	XM1.09.A005A	
10	1	XM1.13.A003A	
11	1	XM1.13.P501A	
12	1	DIN 912 M5 x 35	
13	21	DIN 912 M6 x 12	
14	20	DIN 912 M6 x 20	
15	20	DIN 912 M6 x 25	
16	21	DIN 913 - M6 x 8	
17	20	Spring Washer_JIS_6	
18	21	Washer DIN 125 - A 6.4	

DESCRIPTION: 鋁架組 - 12' - 右/ frame set - 12' - LtoRF

GT 112-E

Guiding Modules

SCALE: **1:16**

MATERIAL:

SURFACE:

HARDNESS:

WEIGHT (Kg):

DATE: 2016.01.18 | 2017.07.12

DRAWN BY: 林義碧 | Last modif.

ECN: ECN.XM1.066 | B1

XM1.03.A501B

GENERAL TOLERANCE							
1 - 4	± 0.05	± 0.1	17 - 63	± 0.1	± 0.3	251 - 1000	± 0.3 ± 0.8
5 - 16	± 0.07	± 0.2	64 - 250	± 0.2	± 0.5	>1001	± 0.8 ± 1

Our drawings/designs and their annexes remain our sole property and we confide them to the addressee's personal care. Nobody has the right without our written authorization to copy, reproduce, show or give them to third parties in receipt of personal demand. 我們透露我們的设计圖面與它的附件，但它們仍然是我們專屬的財產。任何人無權在未取得我們的書面文字授權的情況下复制、再制、展示和提供它們給第三者。



www.lns-group.com

TW

Item	Qty.	Part No.	Descr.
1	4	C12115100	
2	8	C13120800	
3	4	C13131000	
4	4	DIN 912 M3 x 8	
5	8	DIN 912 M4 x 25	
6	12	DIN 912 M5 x 16	
7	6	DIN 912 M5 x 20	
8	3	XM1.05.P002C	
9	3	XM1.05.P005C	
10	1	XM1.05.P008C	右 - LtoRF
10	1	XM1.05.P009C	左 - RtoLF
11	1	XM1.05.P015A	右 - LtoRF
11	1	XM1.05.P016A	左 - RtoLF
12	1	XM1.05.P202A	
13	3	XT161050200	

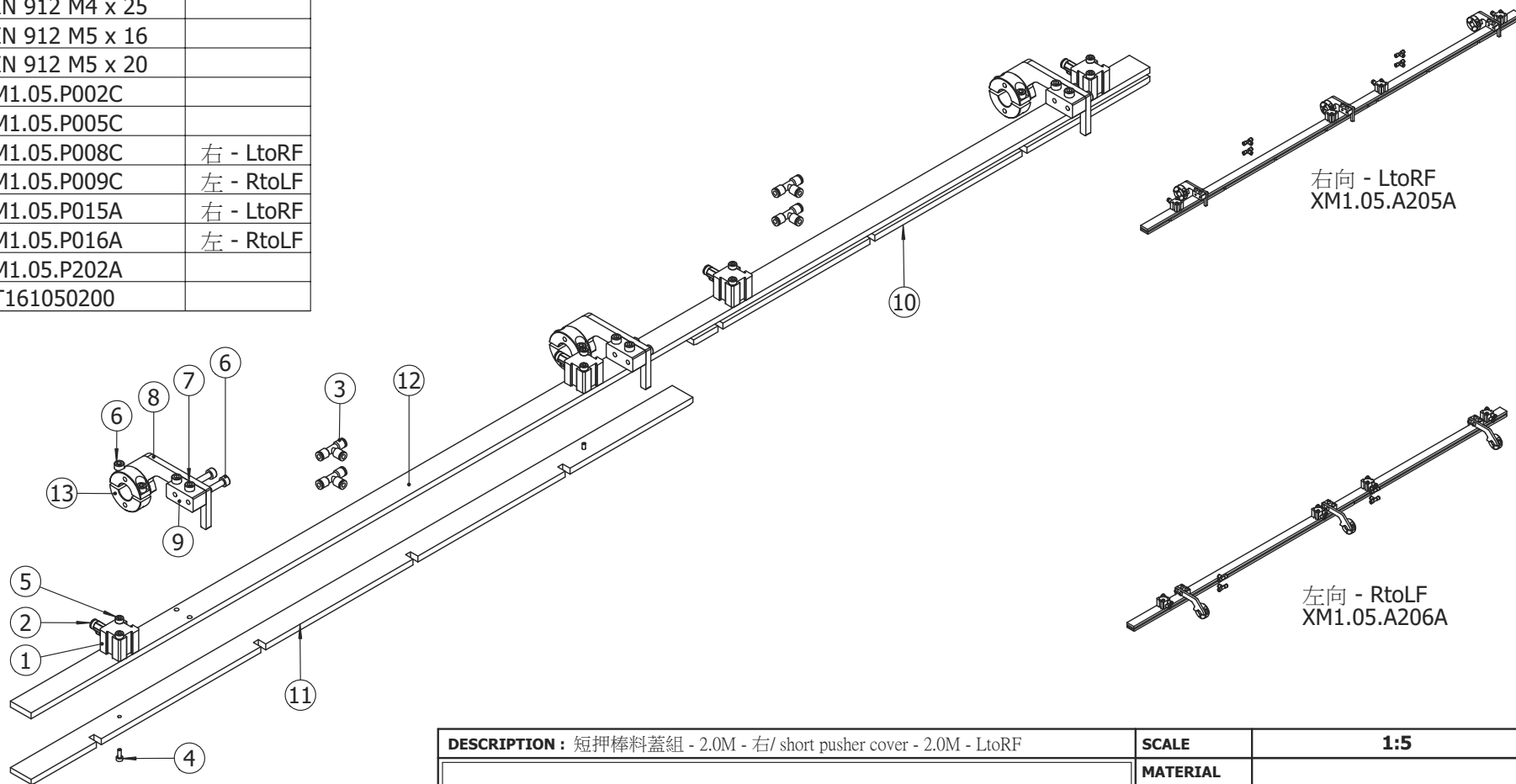

DESCRIPTION : 短押棒料蓋組 - 2.0M - 右/ short pusher cover - 2.0M - LtoRF

SCALE 1:5

GT 112-E Guiding opening

MATERIAL		
SURFACE		
HARDNESS		
WEIGHT (Kg)		
DATE	2014.06.25	
DRAWN BY	林義碧	Last modif.
ECN	XM1-001	

GENERAL TOLERANCE

1 - 4	± 0.05	± 0.1	17 - 63	± 0.1	± 0.3	251 - 1000	± 0.3	± 0.8
5 - 16	± 0.07	± 0.2	64 - 250	± 0.2	± 0.5	>1001	± 0.8	± 1

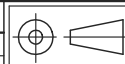

Our drawings/designs and their annexes remain our sole property and we confide them to the addressee's personal care. Nobody has the right without our written authorization to copy, reproduce, show or give them to third parties. 在收件人个人需求下, 我们透露我们的设计图面与它的附件, 但它们仍然是我们专属的财产。任何人无权在未取得我们的书面授权的情况下复制、再制、展示和提供它们给第三者。



www.lns-group.com

TW

XM1.05.A205A

Item	Qty.	Part No.	Descr.
1	10	C12115100	
2	20	C13120800	
3	10	C13131000	
4	6	XM1.05.P002C	
5	6	XM1.05.P005C	
6	1	XM1.05.P502A	
7	4	XM1.05.P504A	右-LtoRF
7	4	XM1.05.P505A	左-RtoLF
8	1	XM1.05.P506A	右-LtoRF
8	1	XM1.05.P507A	左-RtoLF
9	6	XT161050200	
10	10	DIN 912 M3 x 8	
11	20	DIN 912 M4 x 25	
12	24	DIN 912 M5 x 16	
13	12	DIN 912 M5 x 20	

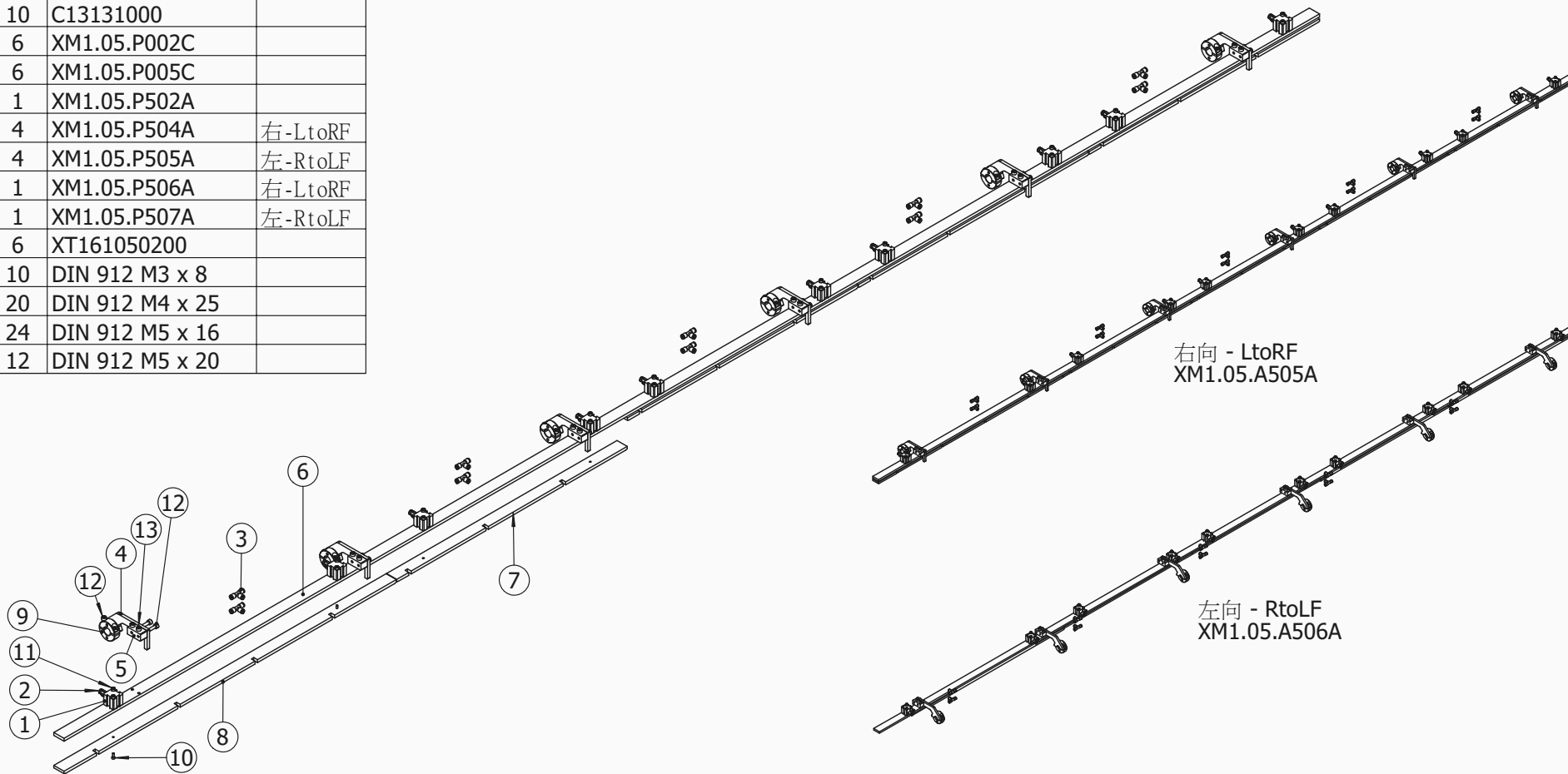

DESCRIPTION: 短押棒料蓋組 - 12' - 右/ short pusher channel cover - 12' - LtoRF

SCALE 1:10

GT 112-E

Guiding opening

MATERIAL

SURFACE

HARDNESS

WEIGHT (Kg)

DATE

2016.01.18

DRAWN BY

林義碧

Last modif.

ECN

ECN.XM1.031

A0

XM1.05.A505A

GENERAL TOLERANCE

1 - 4	± 0.05	± 0.1	17 - 63	± 0.1	± 0.3	251 - 1000	± 0.3	± 0.8
5 - 16	$\neq 0.07$	± 0.2	64 - 250	$\neq 0.2$	± 0.5	>1001	$\neq 0.8$	± 1

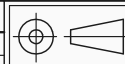

Our drawings/designs and their annexes remain our sole property and we confide them to the addressee's personal care. Nobody has the right without our written authorization to copy, reproduce, show or give them to third parties in收件人个人需求下, 我们透露我们的设计图面与它的附件, 但它们仍然是我们专属的财产。任何人无权在未取得我们的书面文字授权的情况下复制、再制、展示和提供它们给第三者。

LNS
GROUP

www.lns-group.com

TW

Item	Qty.	Part No.	Descr.
1	2	C13130900	
2	2	ST1102400	
3	2	ST5100500	
4	1	XM1.05.A005A	
5	1	XM1.05.P013A	
6	2	DIN 912 M6 x 10	

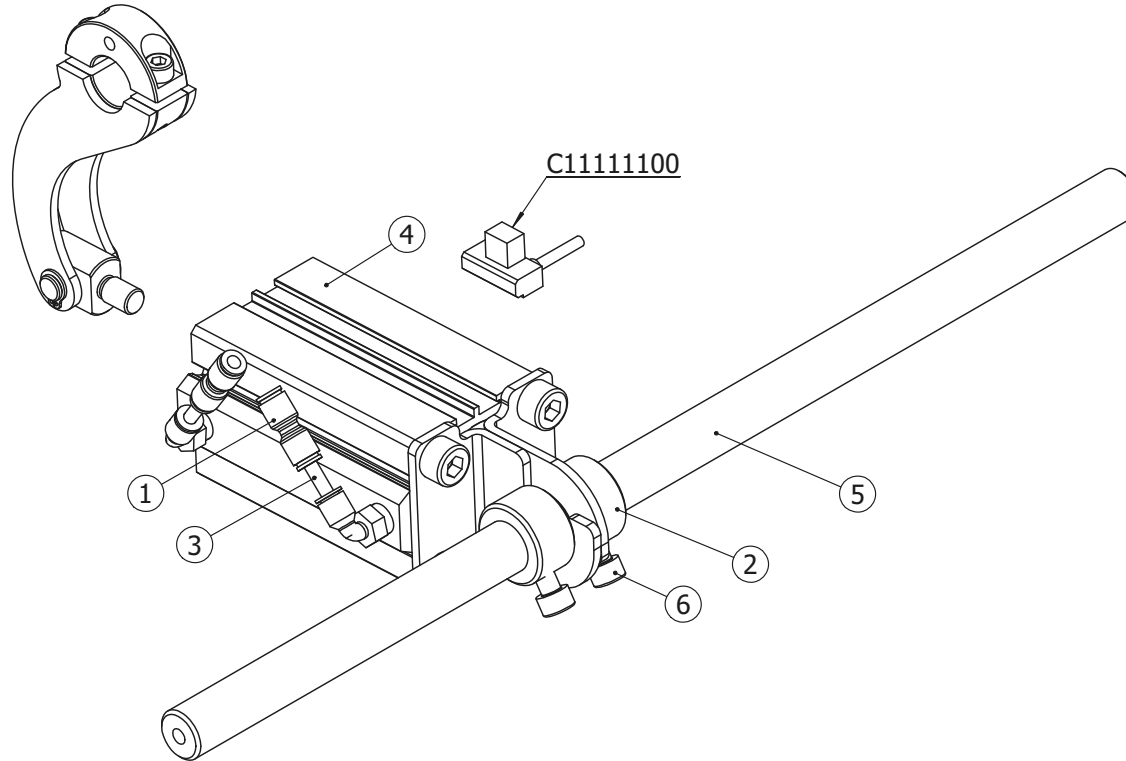

DESCRIPTION: 開蓋汽缸支架組 / Open Cover Cylinder Set

SCALE: 1:2

GT 112-E Guiding opening

MATERIAL

SURFACE

HARDNESS

WEIGHT (Kg)

DATE: 2014.06.25

DRAWN BY: 林義碧 Last modif.

ECN: XM1-001

XM1.05.A307A

GENERAL TOLERANCE

1 - 4	± 0.05	± 0.1	17 - 63	± 0.1	± 0.3	251 - 1000	± 0.3	± 0.8
5 - 16	$\neq 0.07$	± 0.2	64 - 250	$\neq 0.2$	± 0.5	>1001	$\neq 0.8$	± 1

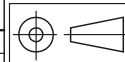

Our drawings/designs and their annexes remain our sole property and we confide them to the addressee's personal care. Nobody has the right without our written authorization to copy, reproduce, show or give them to third parties in request of the addressee. 我們透露我們的设计图面与它的附件, 但它们仍然是我们专属的财产。任何人无权在未获得我们的书面文字授权的情况下复制、再制、展示和提供它们给第三者。



www.lns-group.com

TW

Item	Qty.	Part No.	Descr.
1	1	AT134130000	
2	8	D6342100	
3	6	M20351800	
4	6	XA1.06.P083A	
5	2	XM1.06.P508A.01	
6	2	XM1.06.P510A	
7	2	DIN 912 M8 x 12	
8	36	JIS B 1174_M5x10_ELEC	
9	9	Nut_DIN 934 M8	
10	5	OUT Hex JIS M8x20	
11	2	OUT Hex JIS M8x30	
12	5	Washer DIN 125 - A 8.4	

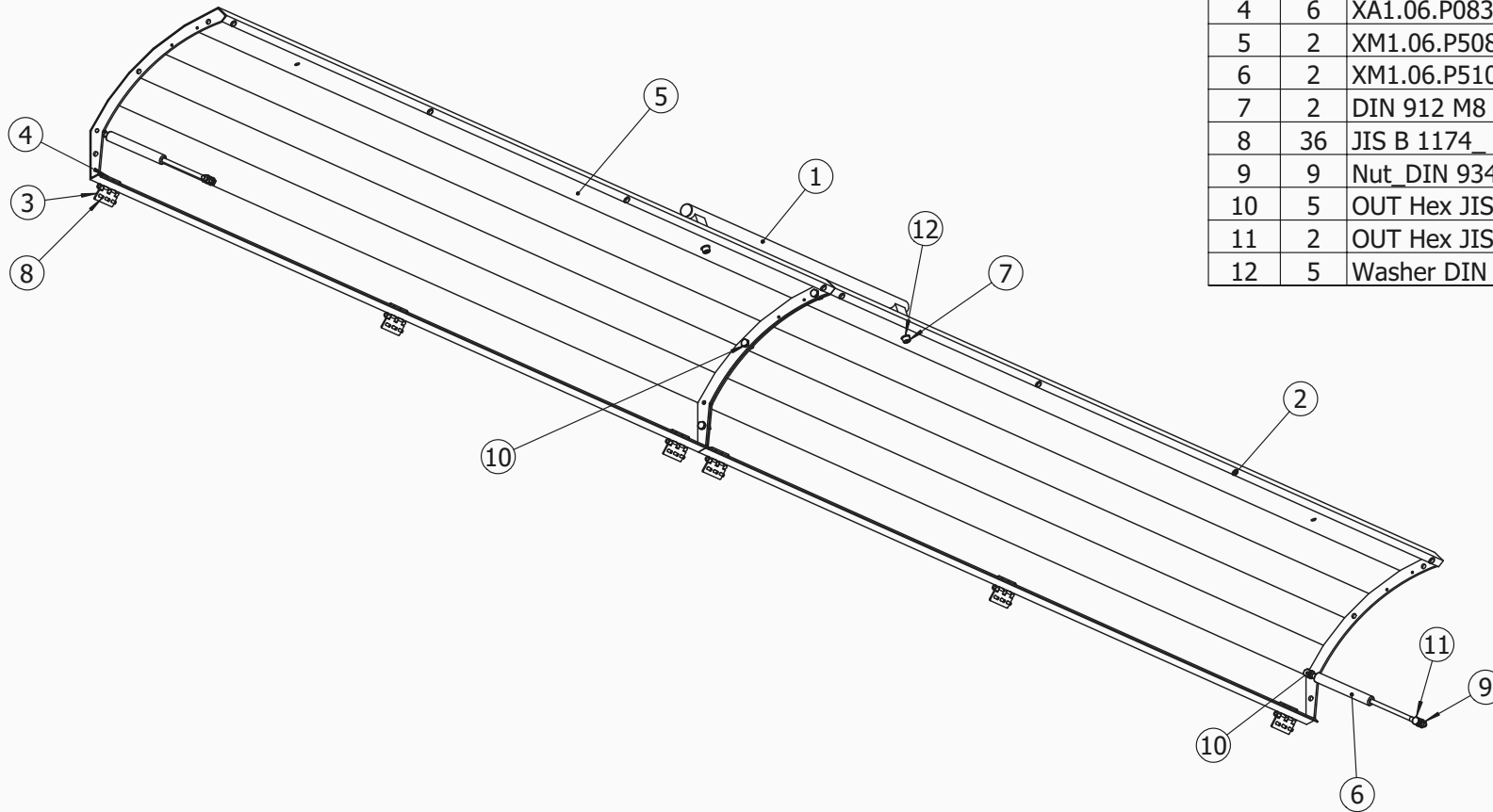

DESCRIPTION: 全罩上蓋組 - 12' / full cover set - 12'		SCALE	1:12
<h1>GT 112-E</h1> <h2>Cover</h2>		MATERIAL	
		SURFACE	
		HARDNESS	
		WEIGHT (Kg)	
		DATE	2016.01.18
		DRAWN BY	林義碧 Last modif.
		ECN	ECN.XM1.031 A0
		XM1.06.A501A	

GENERAL TOLERANCE								
1 - 4	± 0.05	± 0.1	17 - 63	± 0.1	± 0.3	251 - 1000	± 0.3	± 0.8
5 - 16	± 0.07	± 0.2	64 - 250	± 0.2	± 0.5	>1001	± 0.8	± 1

Our drawings/designs and their annexes remain our sole property and we confide them to the addressee's personal care. Nobody has the right without our written authorization to copy, reproduce, show or give them to third parties. 在收件人个人需求下，我们透露我们的设计图面与它的附件，但它们仍然是我们专属的财产。任何人无权在未取得我们的书面文字授权的情况下复制、再制、展示和提供它们给第三者。



www.lns-group.com

TW

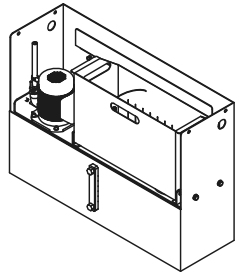

右向 - LtoRF
XM1.09.A001A

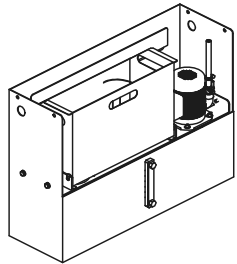

左向 - RtoLF
XM1.09.A002A

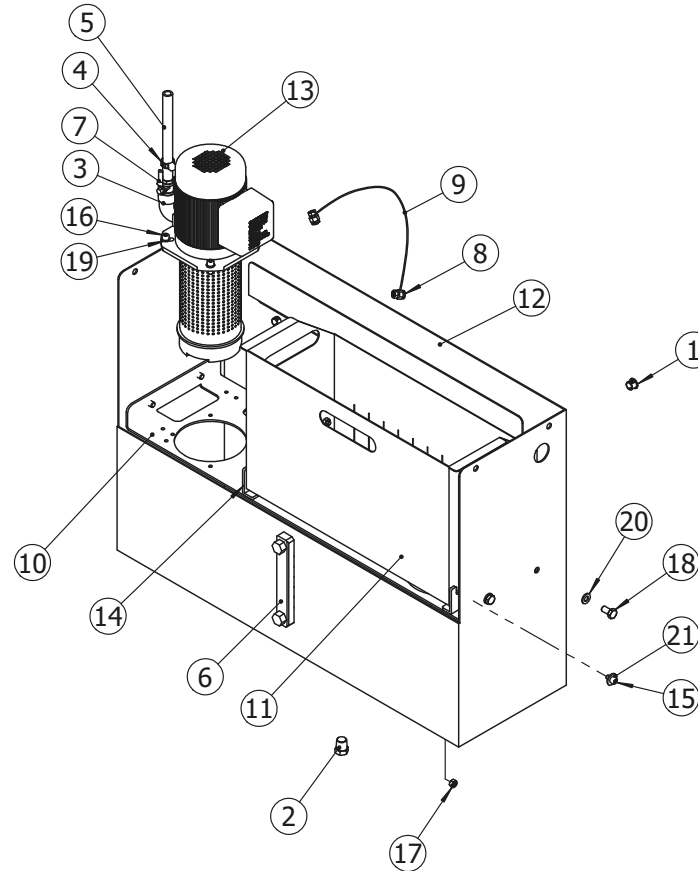

Item	Qty.	Part No.	Descr.
1	2	B20130112	
2	1	C14110300	
3	1	C16140600	
4	1	C17110600	
5	1	C17120210	
6	1	C17120400	
7	1	C17130300	
8	2	XF12317000000	
9	1	XF12318000000	
10	1	XM1.09.P001A.02	
11	1	XT13501000002	
12	1	XT13502000002	
13	1	XT135050000	
14	2	XT135070000	
15	8	DIN 912 M6 x 10_BLACK	
16	4	DIN 912 M6 x 16_BLACK	
17	6	Nut_DIN 934 M6	
18	4	OUT Hex JIS M8x16	
19	4	Washer DIN 125 - A 6.4	
20	4	Washer DIN 125 - A 8.4	
21	2	Washer DIN 9021 - 6.4	

DESCRIPTION : 油箱組 - 右/ hydraulic tank set - LtoRF

GT 112-E Hydraulic Tank

SCALE	1:10	
MATERIAL		
SURFACE		
HARDNESS		
WEIGHT (Kg)		
DATE	2014.06.25	
DRAWN BY	林義碧	Last modif.
ECN	XM1-001	

GENERAL TOLERANCE							
1 - 4	± 0.05	± 0.1	17 - 63	± 0.1	± 0.3	251 - 1000	± 0.3 ± 0.8
5 - 16	± 0.07	± 0.2	64 - 250	± 0.2	± 0.5	>1001	± 0.8 ± 1

Our drawings/designs and their annexes remain our sole property and we confide them to the addressee's personal care. Nobody has the right without our written authorization to copy, reproduce, show or give them to third parties. 在收件人个人需求下, 我们透露我们的设计图面与它的附件, 但它们仍然是我们专属的财产。任何人无权在未获得我们的书面文字授权的情况下复制、再制、展示和提供它们给第三者。



www.lns-group.com

TW

XM1.09.A001A

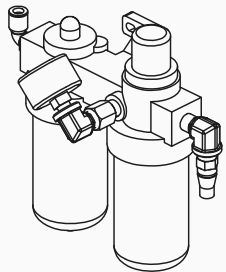

右向 - LtoRF
XM1.12.A009A

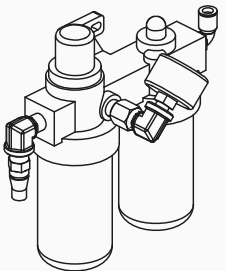

左向 - RtoLF
XM1.12.A010A

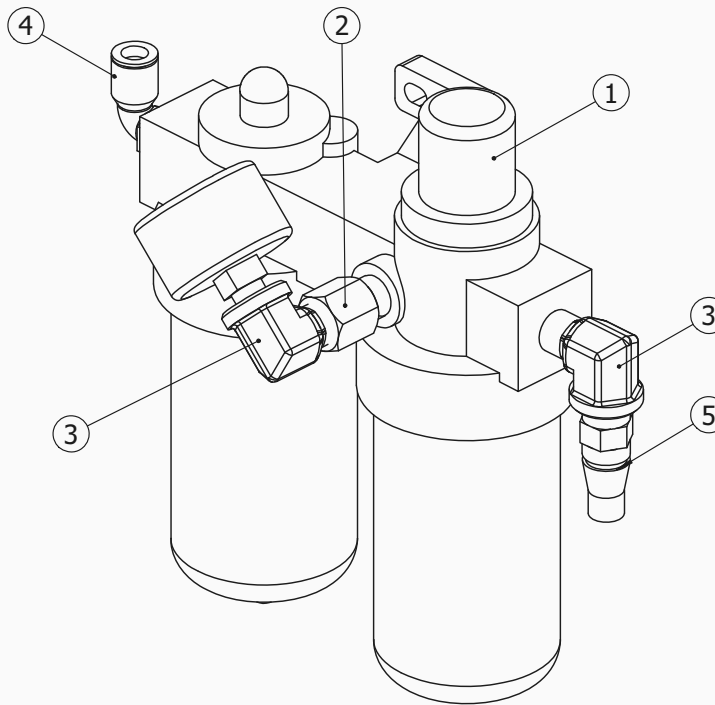

Item	Qty.	Part No.	Descr.
1	1	C11120100	
2	1	C11121000	
3	2	C11121100	
4	1	C13110500	
5	1	C13120300	

GENERAL TOLERANCE

1 - 4	± 0.05	± 0.1	17 - 63	± 0.2	± 0.3	251 - 1000	± 0.3	± 0.8
5 - 16	± 0.07	± 0.2	64 - 250	± 0.2	± 0.5	>1001	± 0.8	± 1

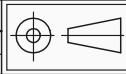

Our drawings/designs and their annexes remain our sole property and we confide them to the addressee's personal care. Nobody has the right without our written authorization to copy, reproduce, show or give them to third parties in recipient's personal demand. 我们透露我们的设计图面与它的附件，但它们仍然是我们专属的财产。任何人无权在未获得我们的书面文字授权的情况下复制、再制、展示和提供它们给第三者。

DESCRIPTION: 三點組合組 - 右/ pneumatic - LtoRF

GT 112-E Pneumatic



www.lns-group.com

TW

SCALE	1:2	
MATERIAL		
SURFACE		
HARDNESS		
WEIGHT (Kg)		
DATE	2017.04.18	
DRAWN BY	林義碧	Last modif.
ECN	ECM.XM1.055	

XM1.12.A009A

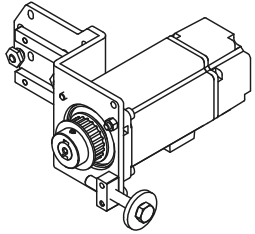

右向 - LtoRF
XM1.13.A001A

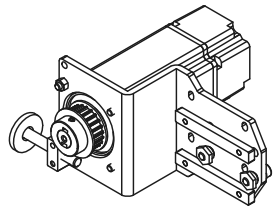

左向 - RtoLF
XM1.13.A002A

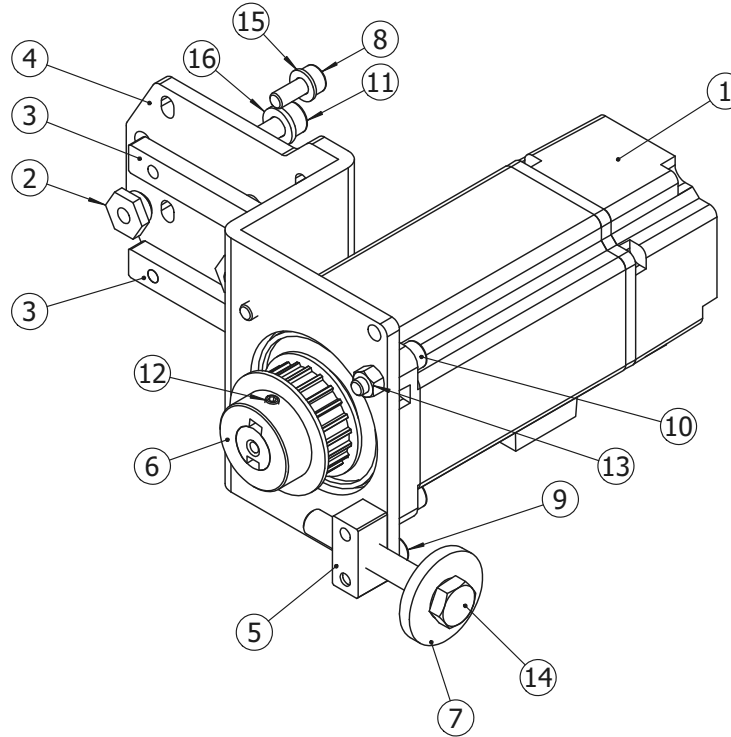

Item	Qty.	Part No.	Descr.
1	1	B14120203	
2	2	XH14107000000	
3	2	XM1.13.P002B	
4	1	XM1.13.P003B	
5	1	XM1.13.P004A	
6	1	XM1.13.P005A	
7	1	XT111080000	
8	4	DIN 912 M5 x 12	
9	3	DIN 912 M5 x 16	
10	2	DIN 912 M5 x 20	
11	2	DIN 912 M6 x 16	
12	1	DIN 913 - M4 x 6	
13	1	Nut_DIN 934 M5	
14	1	OUT Hex JIS M8x55	
15	2	Washer DIN 125 - A 5.3	
16	2	Washer DIN 125 - A 6.4	

DESCRIPTION : 傳動組 - 右/ drive - RtoLF

GT 112-E Drive

SCALE 1:2

MATERIAL

SURFACE

HARDNESS

WEIGHT (Kg)

DATE

2014.06.25

DRAWN BY

林義碧

Last modif.

ECN

XM1-001

XM1.13.A001A

GENERAL TOLERANCE

1 - 4	± 0.05	± 0.1	17 - 63	± 0.1	± 0.3	251 - 1000	± 0.3	± 0.8
5 - 16	± 0.07	± 0.2	64 - 250	± 0.2	± 0.5	>1001	± 0.8	± 1

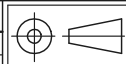

Our drawings/designs and their annexes remain our sole property and we confide them to the addressee's personal care. Nobody has the right without our written authorization to copy, reproduce, show or give them to third parties. 在收件人个人需求下, 我们透露我们的设计图面与它的附件, 但它们仍然是我们专属的财产。任何人无权在未获得我们的书面文字授权的情况下复制、再制、展示和提供它们给第三者。



www.lns-group.com

TW

Item	Qty.	Part No.	Descr.
1	2	D6211200	
2	1	XM1.13.P006B	
3	2	XM1.13.P007B	
4	2	XM1.13.P008A	
5	2	XM1.13.P009A	
6	8	DIN 912 M3x10	
7	2	DIN 912 M5 x 10	
8	2	Pin-5x20	

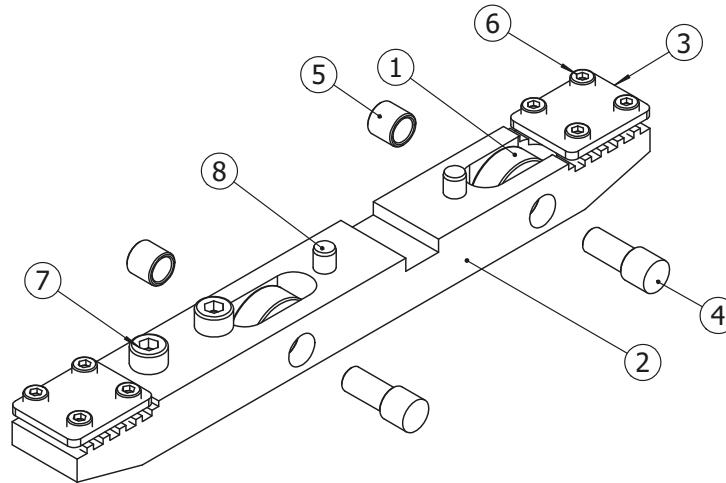

DESCRIPTION: 鏈條連接塊組/ chain connected set

SCALE 1:1.5

**GT 112-E
Drive**

MATERIAL

SURFACE

HARDNESS

WEIGHT (Kg)

DATE 2014.06.25

DRAWN BY 林義碧 Last modif.

ECN XM1-001

XM1.13.A003A

GENERAL TOLERANCE

1 - 4	± 0.05	± 0.1	17 - 63	± 0.1	± 0.3	251 - 1000	± 0.3	± 0.8
5 - 16	± 0.07	± 0.2	64 - 250	± 0.2	± 0.5	>1001	± 0.8	± 1

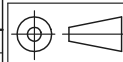

Our drawings/designs and their annexes remain our sole property and we confide them to the addressee's personal care. Nobody has the right-without our written authorization-to copy, reproduce, show or give them to third parties in收件人个人需求下, 我们透露我们的设计图面与它的附件, 但它们仍然是我们专属的财产。任何人无权在未取得我们的书面文字授权的情况下复制、再制、展示和提供它们给第三者。



www.lns-group.com

TW

Item	Qty.	Part No.	Descr.
1	2	E04441000	
2	2	K15421500	
3	4	XH14107000000	
4	1	XM1.13.P010B	
5	1	XM1.13.P011C	
6	1	XM1.13.P012A	
7	1	XM1.13.P013D	
8	1	XM1.13.P014A	
9	1	XM1.13.P015A	
10	1	Circlip DIN 471 - 10 x 1	
11	1	Circlip DIN 471 - 12 x 1	
12	2	Circlip DIN 472 - 26 x 1.2	
13	2	Circlip DIN 472 - 28 x 1.2	
14	1	DIN 912 M4 x 16	
15	2	DIN 912 M6 x 20	
16	2	DIN 912 M6 x 30	
17	1	DIN 912 M6 x 35	
18	2	Key_DIN 4x4x20	
19	4	Pin-5x10	
20	5	Washer DIN 125 - A 6.4	

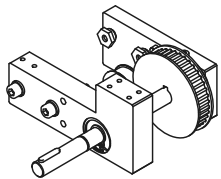
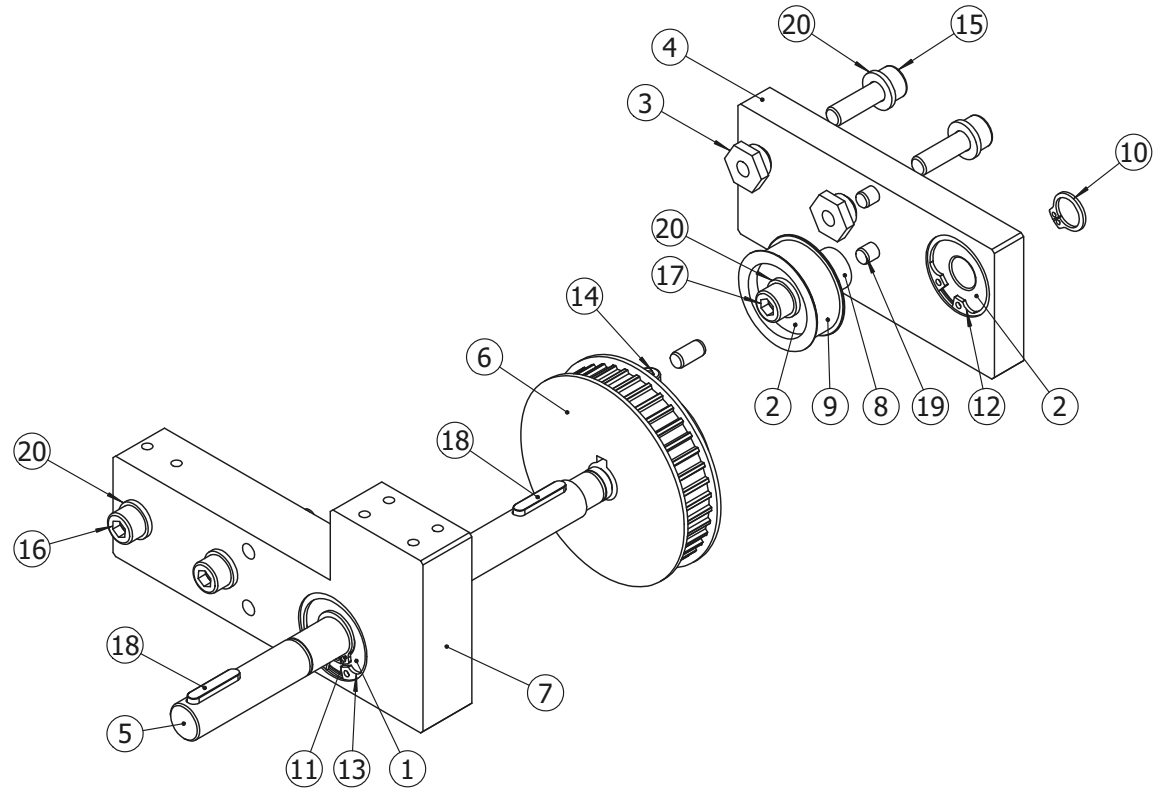

右向 - LtoRF
XM1.13.A004A

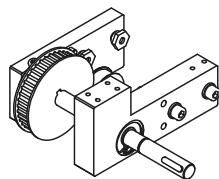

左向 - RtoLF
XM1.13.A005A

GENERAL TOLERANCE

1 - 4	± 0.05	± 0.1	17 - 63	± 0.1	± 0.3	251 - 1000	± 0.3	± 0.8
5 - 16	± 0.07	± 0.2	64 - 250	± 0.2	± 0.5	>1001	± 0.8	± 1

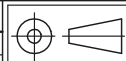

Our drawings/designs and their annexes remain our sole property and we confide them to the addressee's personal care. Nobody has the right-without our written authorization-to copy, reproduce, show or give them to third parties in收件人个人需求下, 我们透露我们的设计图面与它的附件, 但它们仍然是我们专属的财产。任何人无权在未获得我们的书面文字授权的情况下复制、再制、展示和提供它们给第三者。

DESCRIPTION: 惰輪組 - 右/ idler pulley set - LtoRF

GT 112-E Drive



www.lns-group.com

TW

SCALE	1:2	
MATERIAL		
SURFACE		
HARDNESS		
WEIGHT (Kg)		
DATE	2014.06.25	
DRAWN BY	林義碧	Last modif.
ECN	XM1-001	

XM1.13.A004A

LtoRF			
Model	Type	Qty.	Part No.
2.0M	Ø7	6	XM1.14.P046A.07
2.5M		8	
3.0M		10	
12'		11	
4.0M		12	

RtoLF			
Model	Type	Qty.	Part No.
2.0M	Ø7	6	XM1.14.P047A.07
2.5M		8	
3.0M		10	
12'		11	
4.0M		12	

Item	Qty.	Part No.	Descr.
1	2	E04110500	
2	1	XH11503000000	
3	1	XH11504000000	
4	1	XH11506000000	
5	1	XM1.14.A001A	右 - LtoRF
5	1	XM1.14.A002A	左 - RtoLF
6	1	XM1.14.P045A	
7	2	DIN 6912 - M5 x 10	
8	2	DIN 912 M5 x 20	
9	2	DIN 912 M5 x 45	
10	4	DIN 913 - M4 x 4	

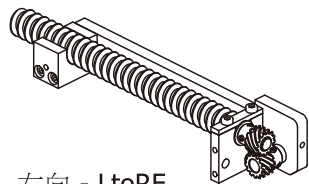

右向 - LtoRF
XM1.14.A003B

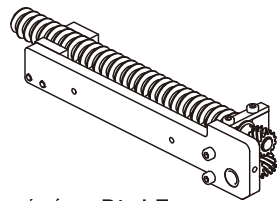

左向 - RtoLF
XM1.14.A004B

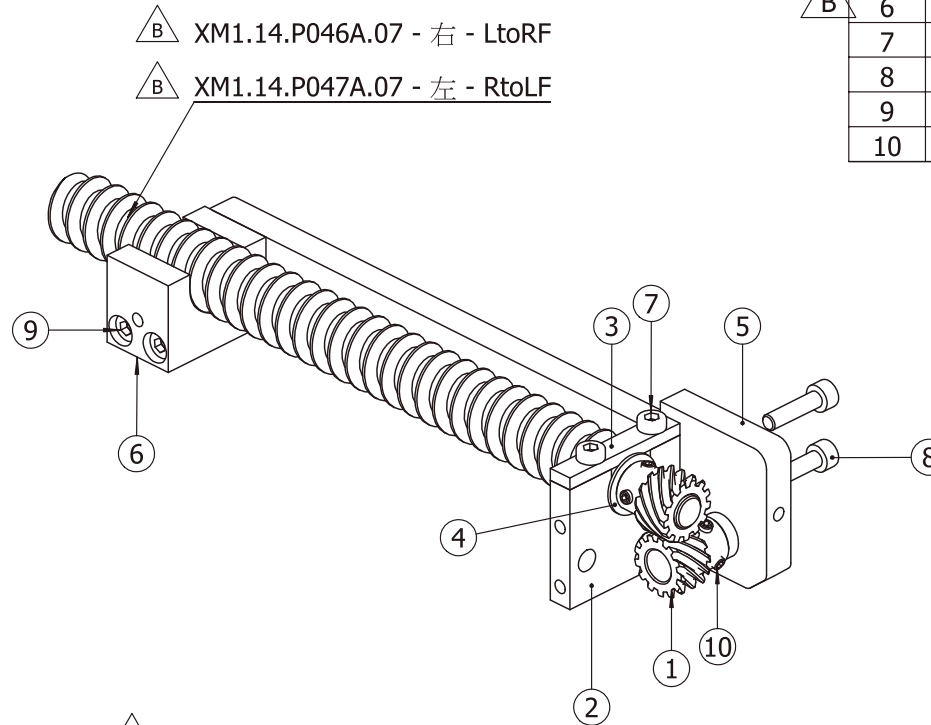

B = 3

DESCRIPTION: 螺桿支撐架組 - 右/ screw propeller support bracket set - LtoRF

SCALE 1:2

GT 112-E
Magazine

MATERIAL

SURFACE

HARDNESS

WEIGHT (Kg)

DATE

2014.06.25

2017.06.27

DRAWN BY

林義碧

Last modif.

ECN

ECN.XM1.065

XM1.14.A003B

GENERAL TOLERANCE

1 - 4	± 0.05	± 0.1	17 - 63	± 0.1	± 0.3	251 - 1000	± 0.3	± 0.8
5 - 16	± 0.07	± 0.2	64 - 250	± 0.2	± 0.5	>1001	± 0.8	± 1

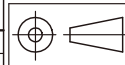

Our drawings/designs and their annexes remain our sole property and we confide them to the addressee's personal care. Nobody has the right without our written authorization to copy, reproduce, show or give them to third parties. 在收件人个人需求下, 我们透露我们的设计图面与它的附件, 但它们仍然是我们专属的财产。任何人无权在未取得我们的书面授权的情况下复制、再制、展示和提供它们给第三者。



www.lns-group.com

TW

△B XM1.14.P046A.07 - 右 - LtoRF

△B XM1.14.P047A.07 - 左 - RtoLF

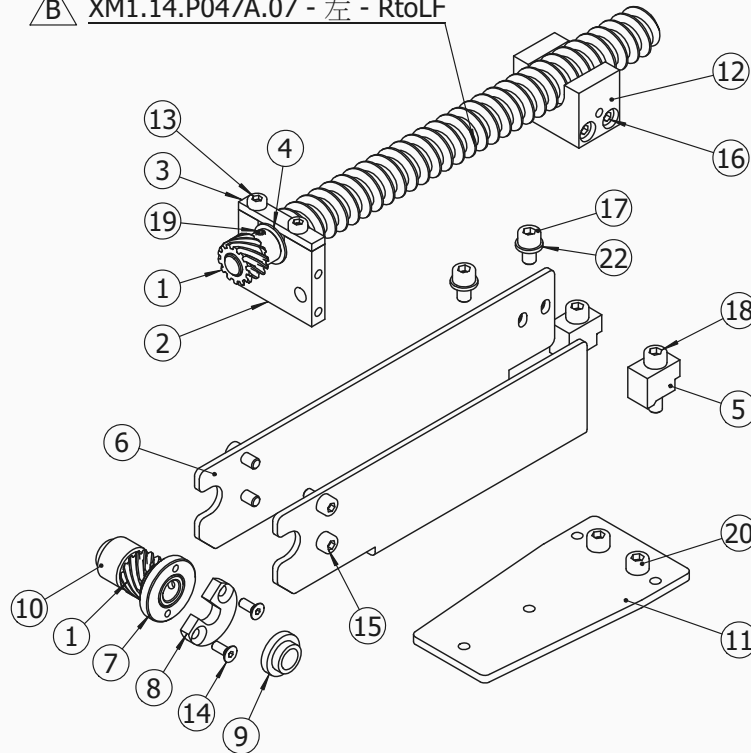

△B = 3

Item	Qty.	Part No.	Descr.
1	2	E04110500	
2	1	XH11503000000	
3	1	XH11504000000	
4	1	XH11506000000	
5	2	XH13105000000	
6	1	XM1.14.P022C	
7	1	XM1.14.P023A	
8	1	XM1.14.P024A	
9	1	XM1.14.P025A	
10	1	XM1.14.P026A	
11	1	XM1.14.P027B	
△B 12	1	XM1.14.P045A	
13	2	DIN 6912 - M5 x 10	
14	2	DIN 7991 - M4 x 10	
15	4	DIN 912 M5 x 10	
16	2	DIN 912 M5 x 40	
17	2	DIN 912 M6 x 10	
18	2	DIN 912 M6 x 25	
19	2	DIN 913 - M4 x 4	
20	2	DIN912 M6x10_ELEC	
21	2	Nut_DIN 934 M5	
22	2	Washer DIN 125 - A 6.4	

DESCRIPTION: 移動料架/ move loading

SCALE 1:3

GT 112-E Bar loading

MATERIAL

SURFACE

HARDNESS

WEIGHT (Kg)

DATE

2014.06.25

2017.06.27

DRAWN BY

林義碧

Last modif.

ECN

ECN.XM1.065

XM1.14.A005B

GENERAL TOLERANCE

1 - 4	± 0.05	± 0.1	17 - 63	± 0.1	± 0.3	251 - 1000	± 0.3	± 0.8
5 - 16	± 0.07	± 0.2	64 - 250	± 0.2	± 0.5	>1001	± 0.8	± 1

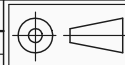

Our drawings/designs and their annexes remain our sole property and we confide them to the addressee's personal care. Nobody has the right without our written authorization to copy, reproduce, show or give them to third parties in recipient's personal demand. We disclose our design drawings with its annexes, but they remain our exclusive property. 任何人无权在未获得我们的书面文字授权的情况下复制、再制、展示和提供它们给第三者。

LNS
GROUP

www.lns-group.com

TW

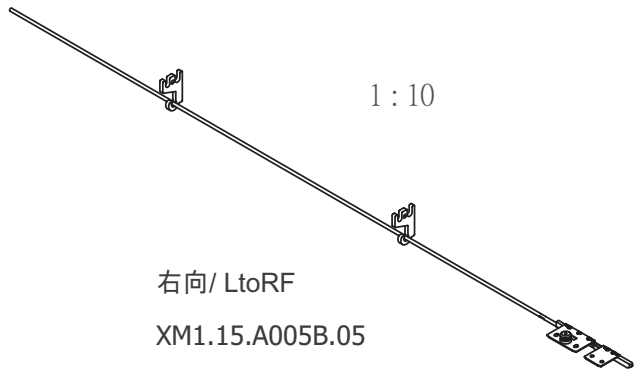

右向/ LtoRF
XM1.15.A005B.05

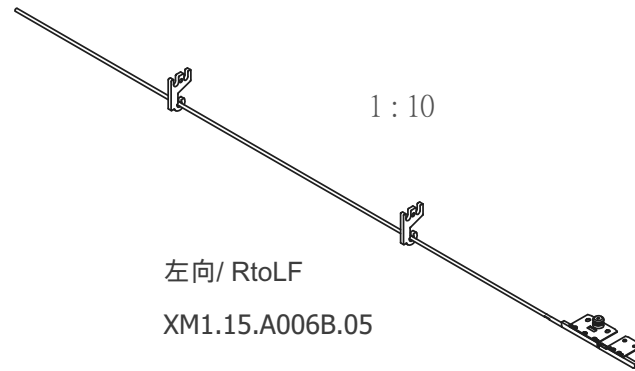

左向/ RtoLF
XM1.15.A006B.05

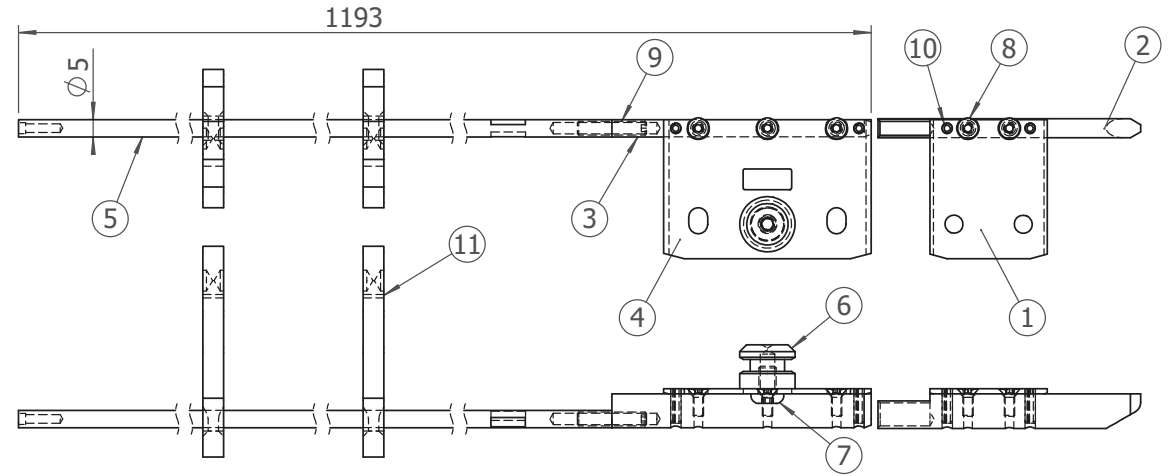

	Part Number	Descr.	Qty.
1	XM1.15.P002B.05		1
2	XM1.15.P001B.05		1
3	XM1.15.P003A.05		1
4	XM1.15.P004D.05		1
5	XM1.15.P015A.05		1
6	XM1.15.P005B		1
7	7380.05.08	SCREW ISO 7380	1
8	7991.03.08	SCREW ISO 10642	5
9	913.04.20.Z	SCREW ISO 4026	1
10	1481.03.10	STRAIGHT PIN ISO 8752	4
11	XM1.15.P007C.05		2

$\triangle B0 = 1$

搭配LNS中軸1.440/ Be Used with LNS rotating sleeve 1.440

GENERAL TOLERANCE							
1 - 4	± 0.05	± 0.1	17 - 63	± 0.1	± 0.3	251 - 1000	± 0.3 ± 0.8
5 - 16	± 0.07	± 0.2	64 - 250	± 0.2	± 0.5	>1001	± 0.8 ± 1

Our drawings/designs and their annexes remain our sole property and we confide them to the addressee's personal care. Nobody has the right without our written authorization to copy, reproduce, show or give them to third parties. 在收件人个人需求下，我们透露我们的设计图面与它的附件，但它们仍然是我们专属的财产。任何人无权在未获得我们的书面文字授权的情况下复制、再制、展示和提供它们给第三者。

DESCRIPTION : LNS - 長押棒組 - 右 - Ø5/ LNS - Long Pusher Set - LtoRF - Ø5

SCALE **1:2**

**GT 112-E
Pusher**

MATERIAL	
SURFACE	
HARDNESS	
WEIGHT (Kg)	
DATE	2015.05.19 2017.06.21
DRAWN BY	Mike Huang Last modif.
ECN	ECN.XM1.064 B0



www.lns-group.com

TW

XM1.15.A005B.05

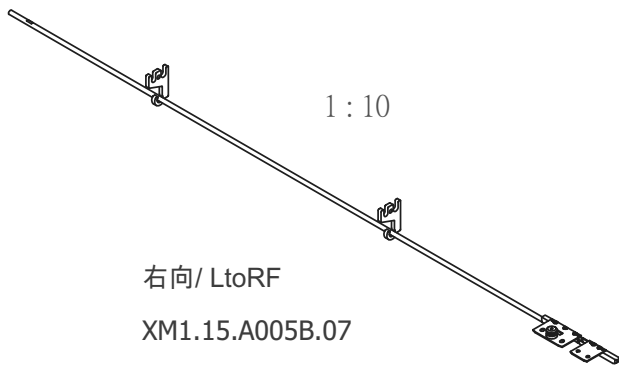

右向/ LtoRF

XM1.15.A005B.07

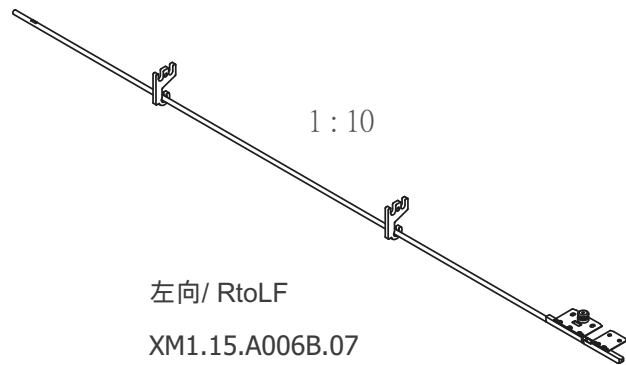

左向/ RtoLF

XM1.15.A006B.07

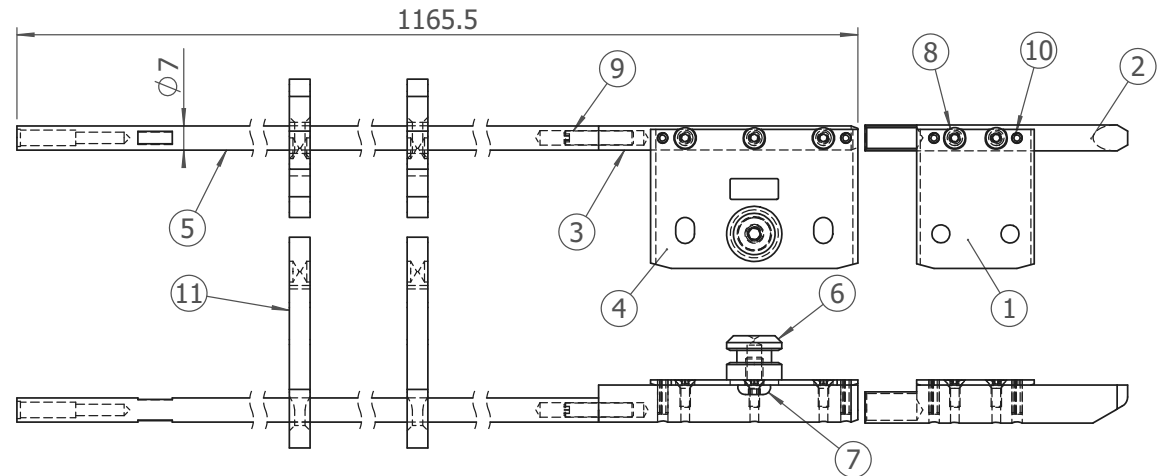

	Part Number	Descr.	Qty.
1	XM1.15.P002B.05		1
2	XM1.15.P001B.07		1
3	XM1.15.P003A.07		1
4	XM1.15.P004D.05		1
5	XM1.15.P015A.07		1
6	XM1.15.P005B		1
7	7380.05.08	SCREW ISO 7380	1
8	7991.03.08	SCREW ISO 10642	5
9	913.04.20.Z	SCREW ISO 4026	1
10	1481.03.10	STRAIGHT PIN ISO 8752	4
11	XM1.15.P007C.07		2

B0

搭配LNS中軸015.15.1064
/ Be used with LNS rotating sleeve 015.15.1064

B0 = 1

GENERAL TOLERANCE							
1 - 4	± 0.05	± 0.1	17 - 63	± 0.2	± 0.3	251 - 1000	± 0.3 / ± 0.8
5 - 16	± 0.07	± 0.2	64 - 250	± 0.2	± 0.5	>1001	± 0.8 / ± 1

Our drawings/designs and their annexes remain our sole property and we confide them to the addressee's personal care. Nobody has the right without our written authorization to copy, reproduce, show or give them to third parties. 在收件人个人需求下, 我们透露我们的设计图面与它的附件, 但它们仍然是我们专属的财产。任何人无权在未获得我们的书面文字授权的情况下复制、再制、展示和提供它们给第三者。

DESCRIPTION : LNS - 長押棒組 - 右 - $\phi 7$ / LNS - Long Pusher Set - LtoRF - $\phi 7$

SCALE **1:2**

**GT 112-E
Pusher**

MATERIAL	
SURFACE	
HARDNESS	
WEIGHT (Kg)	
DATE	2015.05.29 / 2017.06.21
DRAWN BY	Mike Huang / Last modif.
ECN	ECN.XM1.064 / B0



www.lns-group.com

TW

XM1.15.A005B.07

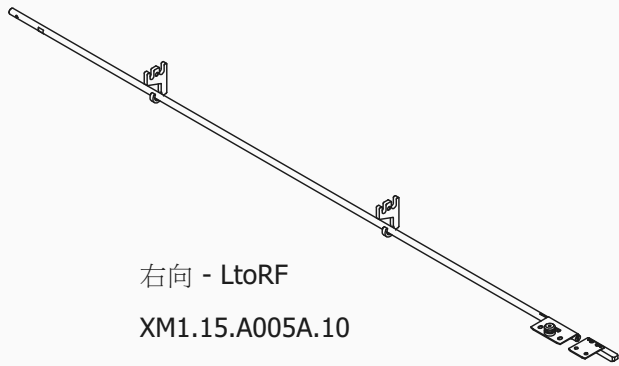

右向 - LtoRF
XM1.15.A005A.10

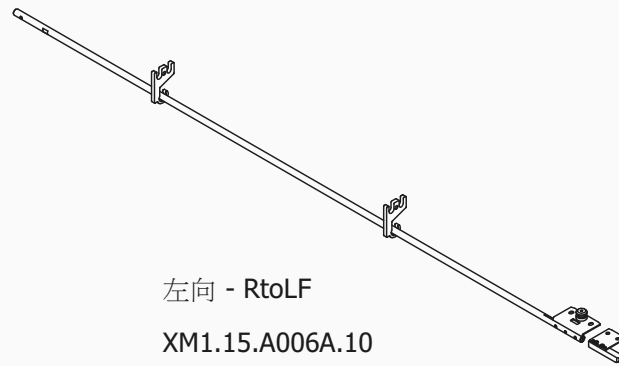

左向 - RtoLF
XM1.15.A006A.10

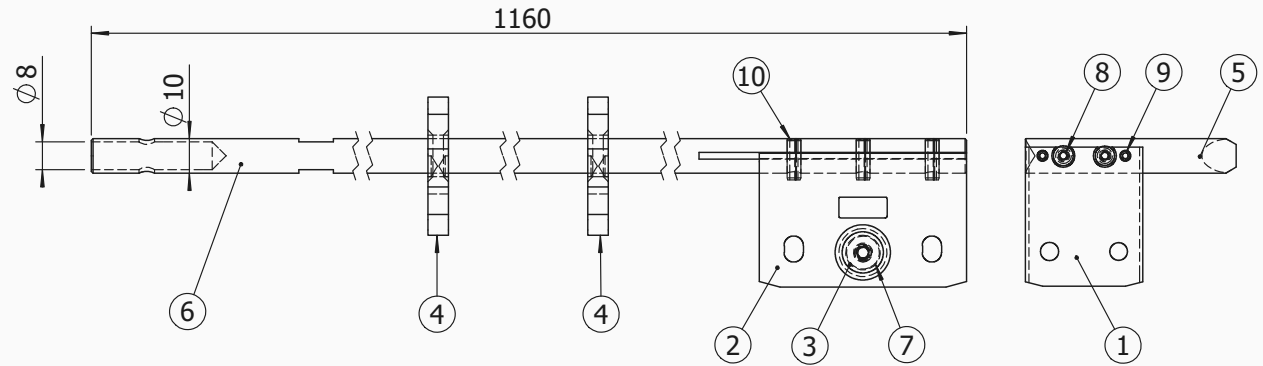

Item	Qty.	Part No.	Descr.
1	1	XM1.15.P002B.05	
2	1	XM1.15.P004C.12	
3	1	XM1.15.P005B	
4	2	XM1.15.P007C.10	
5	1	XM1.15.P008A.10	
6	1	XM1.15.P015A.10	
7	1	7380.05.08.Z	
8	2	DIN 7991 - M3 x 8	
9	2	Spring Pin 3x10	
10	3	Spring Pin 4x12	

搭配 LNS 中軸 015.031.013/100

GENERAL TOLERANCE							
1 - 4	± 0.05	± 0.1	17 - 63	± 0.2	± 0.3	251 - 1000	± 0.3 ± 0.8
5 - 16	± 0.07	± 0.2	64 - 250	± 0.2	± 0.5	>1001	± 0.8 ± 1

Our drawings/designs and their annexes remain our sole property and we confide them to the addressee's personal care. Nobody has the right without our written authorization to copy, reproduce, show or give them to third parties in recipient's personal demand. 我们透露我们的设计图面与它的附件，但它们仍然是我们专属的财产。任何人无权在未获得我们的书面文字授权的情况下复制、再制、展示和提供它们给第三者。

DESCRIPTION : LNS 長押棒組 - 右 - Ø10/ LNS long pusher set - LtoRF - Ø10		SCALE	1:2
<h1>GT 112-E</h1> <h2>Pusher</h2>		MATERIAL	
		SURFACE	
		HARDNESS	
		WEIGHT (Kg)	
		DATE	2017.08.16
		DRAWN BY	林義碧 Last modif.
		ECN	ECN.XM1.060
		XM1.15.A005A.10	



www.lns-group.com

TW

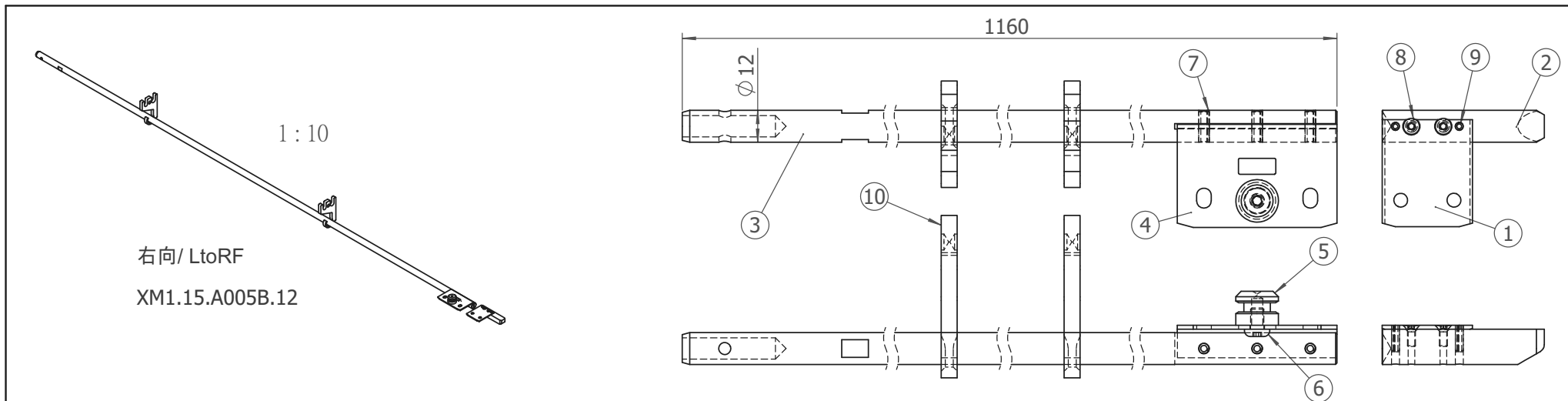

右向/ LtoRF
XM1.15.A005B.12

左向/ RtoLF
XM1.15.A006B.12

	Part Number	Descr.	Qty.
1	XM1.15.P002B.05		1
2	XM1.15.P008A.12		1
3	XM1.15.P015A.12		1
$\triangle B0$	4	XM1.15.P004C.12	1
5	XM1.15.P005B		1
6	7380.05.08	SCREW ISO 7380	1
7	1481.04.12	STRAIGHT PIN ISO 8752	3
8	7991.03.08	SCREW ISO 10642	2
9	1481.03.10	STRAIGHT PIN ISO 8752	2
10	XM1.15.P007C.12		2

搭配LNS中軸015.031.013/100
/ Be used with LNS rotating sleeve 015.031.013/100

GENERAL TOLERANCE							
1 - 4	± 0.05	± 0.1	17 - 63	± 0.2	± 0.3	251 - 1000	± 0.3 ± 0.8
5 - 16	± 0.07	± 0.2	64 - 250	± 0.2	± 0.5	>1001	± 0.8 ± 1

Our drawings/designs and their annexes remain our sole property and we confide them to the addressee's personal care. Nobody has the right-without our written authorization-to copy, reproduce, show or give them to third parties in收件人个人需求下, 我们透露我们的设计图面与它的附件, 但它们仍然是我们专属的财产。任何人无权在未获得我们的书面文字授权的情况下复制、再制、展示和提供它们给第三者。

DESCRIPTION : LNS - 長押棒組 - 右 - Ø12/ LNS - Long Pusher Set - LtoRF - Ø12

SCALE **1:2**

**GT 112-E
Pusher**

MATERIAL	
SURFACE	
HARDNESS	
WEIGHT (Kg)	
DATE	2015.05.29 2017.06.21
DRAWN BY	Mike Huang Last modif.
ECN	ECN.XM1.064 B0



www.lns-group.com

TW

XM1.15.A005B.12

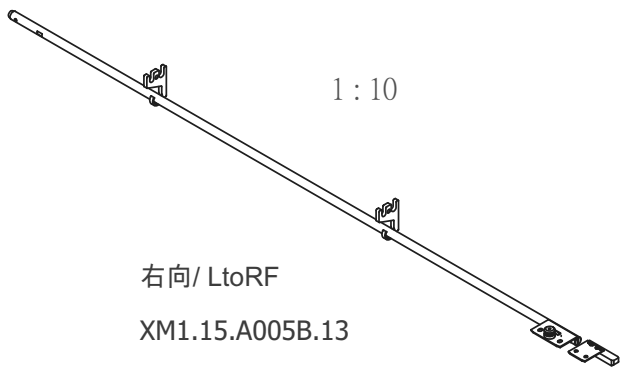

1 : 10
右向/ LtoRF
XM1.15.A005B.13

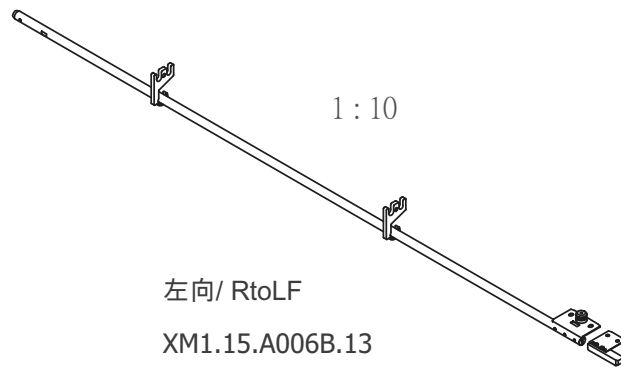

1 : 10
左向/ RtoLF
XM1.15.A006B.13

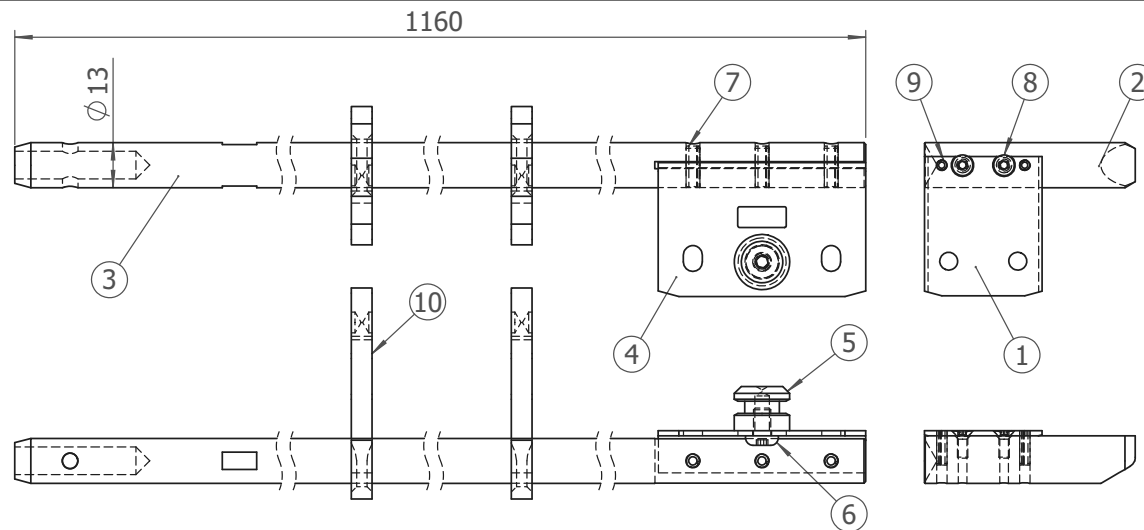

	Part Number	Descr.	Qty.
1	XM1.15.P002B.05		1
2	XM1.15.P008A.13		1
3	XM1.15.P015A.13		1
4	XM1.15.P004C.12		1
5	XM1.15.P005B		1
6	7380.05.08	SCREW ISO 7380	1
7	1481.04.12	STRAIGHT PIN ISO 8752	3
8	7991.03.08	SCREW ISO 10642	2
9	1481.03.10	STRAIGHT PIN ISO 8752	2
10	XM1.15.P007C.13		2

B0

B0 = 1

搭配LNS中軸015.031.013/100
/ Be used with LNS rotating sleeve 015.031.013/100

GENERAL TOLERANCE							
1 - 4	± 0.05	± 0.1	17 - 63	± 0.2	± 0.3	251 - 1000	± 0.3 ± 0.8
5 - 16	± 0.07	± 0.2	64 - 250	± 0.2	± 0.5	>1001	± 0.8 ± 1

Our drawings/designs and their annexes remain our sole property and we confide them to the addressee's personal care. Nobody has the right without our written authorization to copy, reproduce, show or give them to third parties. 在收件人个人需求下，我们透露我们的设计图面与它的附件，但它们仍然是我们专属的财产。任何人无权在未取得我们的书面文字授权的情况下复制、再制、展示和提供它们给第三者。

DESCRIPTION : LNS - 長押棒組 - 右 - Ø13/ LNS - Long Pusher Set - LtoRF - Ø13

GT 112-E Pusher



SCALE	1:2	
MATERIAL		
SURFACE		
HARDNESS		
WEIGHT (Kg)		
DATE	2015.05.19	2017.06.21
DRAWN BY	Mike Huang	Last modif.
ECN	ECN.XM1.064	B0

XM1.15.A005B.13

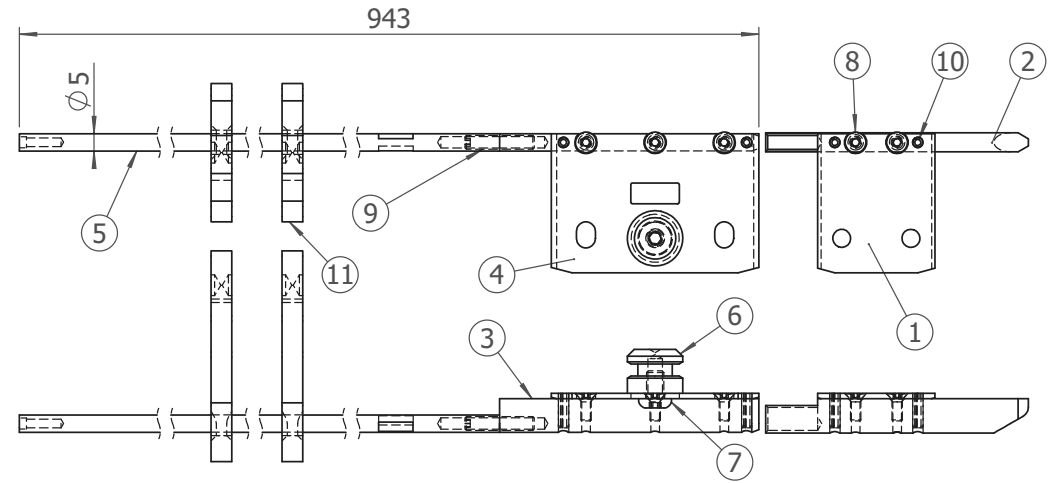
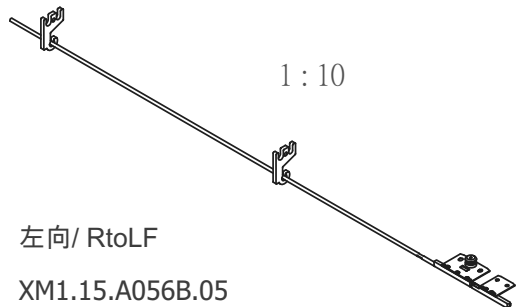
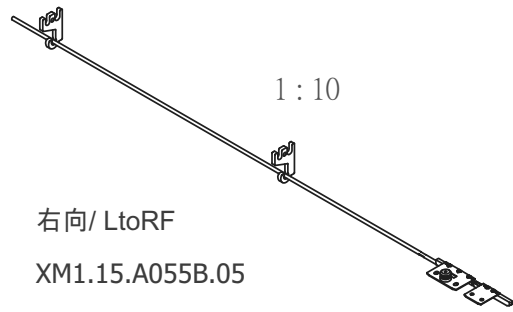

	Part Number	Descr.	Qty.
1	XM1.15.P002B.05		1
2	XM1.15.P001B.05		1
3	XM1.15.P003A.05		1
4	XM1.15.P004D.05		1
5	XM1.15.P055A.05		1
6	XM1.15.P005B		1
7	7380.05.08	SCREW ISO 7380	1
8	7991.03.08	SCREW ISO 10642	5
9	913.04.20.Z	SCREW ISO 4026	1
10	1481.03.10	STRAIGHT PIN ISO 8752	4
11	XM1.15.P007C.05		2

搭配LNS中軸1.440
/ Be used with LNS rotating sleeve 1.440

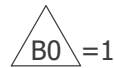

GENERAL TOLERANCE								
1 - 4	± 0.05	± 0.1	17 - 63	± 0.2	± 0.3	251 - 1000	± 0.3	± 0.8
5 - 16	± 0.07	± 0.2	64 - 250	± 0.2	± 0.5	>1001	± 0.8	± 1

Our drawings/designs and their annexes remain our sole property and we confide them to the addressee's personal care. Nobody has the right without our written authorization to copy, reproduce, show or give them to third parties. 在收件人个人需求下，我们透露我们的设计图面与它的附件，但它们仍然是我们专属的财产。任何人无权在未获得我们的书面文字授权的情况下复制、再制、展示和提供它们给第三者。

DESCRIPTION : LNS - 短押棒組 - 右 - Ø5/ LNS - Short Pusher Set - LtoRF - Ø5

SCALE 1:2

GT 112-E
Pusher

MATERIAL		
SURFACE		
HARDNESS		
WEIGHT (Kg)		
DATE	2015.05.19	2017.06.21
DRAWN BY	Mike Huang	Last modif.
ECN	ECN.XM1.064	B0



www.lns-group.com

TW

XM1.15.A055B.05

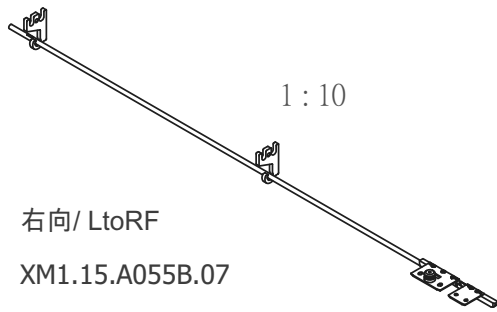

右向/ LtoRF

XM1.15.A055B.07

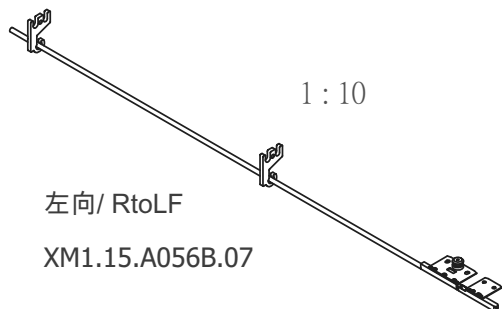

左向/ RtoLF

XM1.15.A056B.07

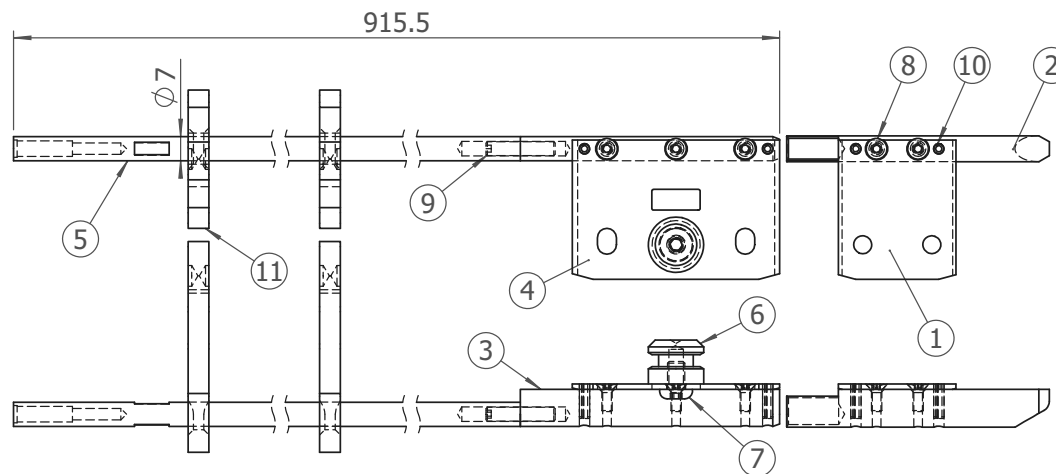

	Part Number	Descr.	Qty.
1	XM1.15.P002B.05		1
2	XM1.15.P001B.07		1
3	XM1.15.P003A.07		1
4	XM1.15.P004D.05		1
5	XM1.15.P055A.07		1
6	XM1.15.P005B		1
7	7380.05.08	SCREW ISO 7380	1
8	7991.03.08	SCREW ISO 10642	5
9	913.04.20.Z	SCREW ISO 4026	1
10	1481.03.10	STRAIGHT PIN ISO 8752	4
11	XM1.15.P007C.07		2

搭配LNS中軸015.15.1064
/ Be used with LNS rotating sleeve 015.15.1064

B0 = 1

GENERAL TOLERANCE								
1 - 4	± 0.05	± 0.1	17 - 63	± 0.2	± 0.3	251 - 1000	± 0.3	± 0.8
5 - 16	± 0.07	± 0.2	64 - 250	± 0.2	± 0.5	>1001	± 0.8	± 1

Our drawings/designs and their annexes remain our sole property and we confide them to the addressee's personal care. Nobody has the right without our written authorization to copy, reproduce, show or give them to third parties. 在收件人个人需求下，我们透露我们的设计图面与它的附件，但它们仍然是我们专属的财产。任何人无权在未取得我们的书面文字授权的情况下复制、再制、展示和提供它们给第三者。

DESCRIPTION : LNS - 短押棒組 - 右 - Ø7 / LNS - Short Pusher Set - LtoRF - Ø7

SCALE 1:2

GT 112-E
Pusher

MATERIAL

SURFACE

HARDNESS

WEIGHT (Kg)

DATE 2015.05.29 2017.06.21

DRAWN BY Mike Huang Last modif.

ECN ECN.XM1.064 B0



www.lns-group.com

TW

XM1.15.A055B.07

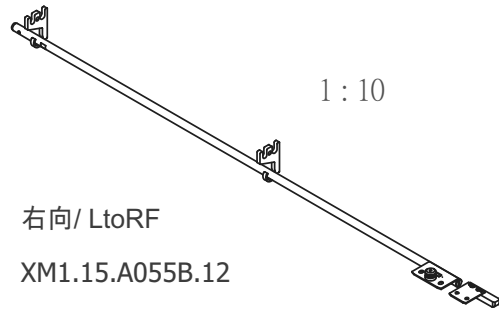

右向/ LtoRF

XM1.15.A055B.12

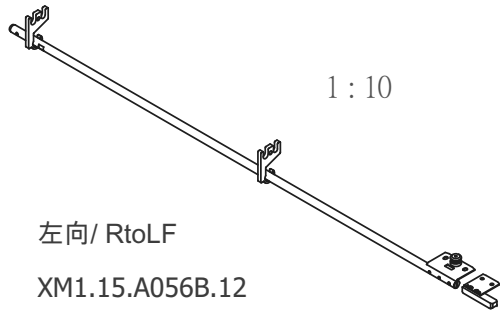

左向/ RtoLF

XM1.15.A056B.12

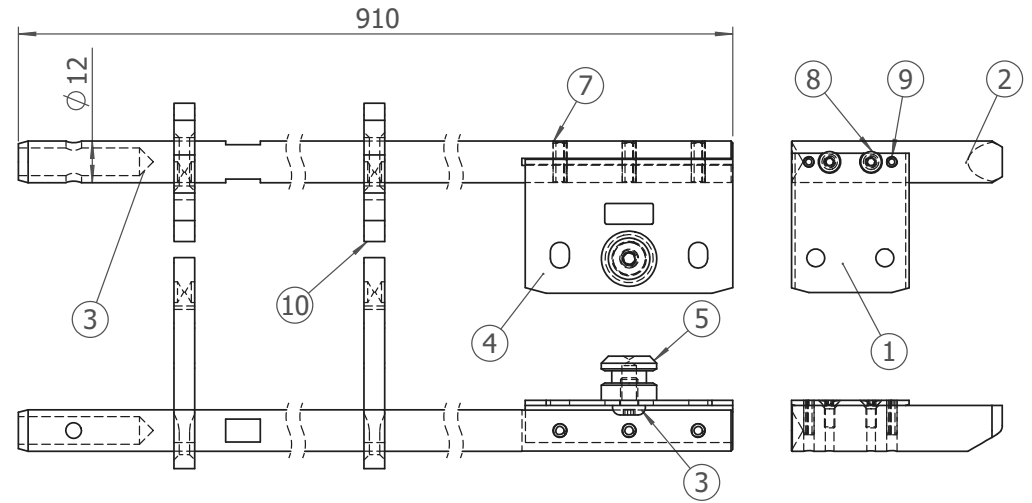

	Part Number	Descr.	Qty.
1	XM1.15.P002B.05		1
2	XM1.15.P008A.12		1
3	XM1.15.P055A.12		1
4	XM1.15.P004C.12		1
5	XM1.15.P005B		1
6	7380.05.08	SCREW ISO 7380	1
7	1481.04.12	STRAIGHT PIN ISO 8752	3
8	7991.03.08	SCREW ISO 10642	2
9	1481.03.10	STRAIGHT PIN ISO 8752	2
10	XM1.15.P007C.12		2

B0

B0 = 1

搭配LNS中軸015.031.013/100
/ Be used with LNS rotating sleeve 015.031.013/100

GENERAL TOLERANCE								
1 - 4	± 0.05	± 0.1	17 - 63	± 0.2	± 0.3	251 - 1000	± 0.3	± 0.8
5 - 16	± 0.07	± 0.2	64 - 250	± 0.2	± 0.5	>1001	± 0.8	± 1

Our drawings/designs and their annexes remain our sole property and we confide them to the addressee's personal care. Nobody has the right without our written authorization to copy, reproduce, show or give them to third parties. 在收件人个人需求下，我们透露我们的设计图面与它的附件，但它们仍然是我们专属的财产。任何人无权在未取得我们的书面文字授权的情况下复制、再制、展示和提供它们给第三者。

DESCRIPTION : LNS 短押棒組 - 右 - Ø12/ LNS - Short Pusher Set - LtoRF - Ø12

SCALE 1:2

GT 112-E
Pusher

MATERIAL		
SURFACE		
HARDNESS		
WEIGHT (Kg)		
DATE	2015.05.29	2017.06.21
DRAWN BY	Mike Huang	Last modif.
ECN	ECN.XM1.064	B0



www.lns-group.com

TW

XM1.15.A055B.12

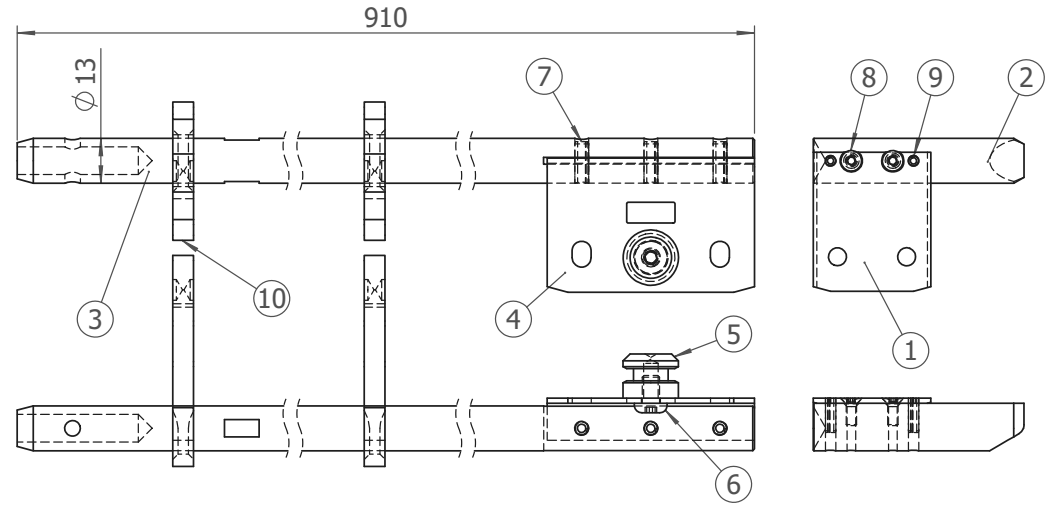
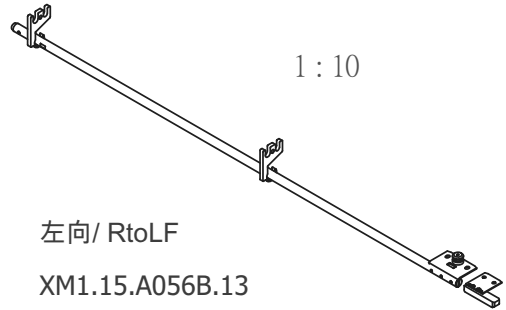
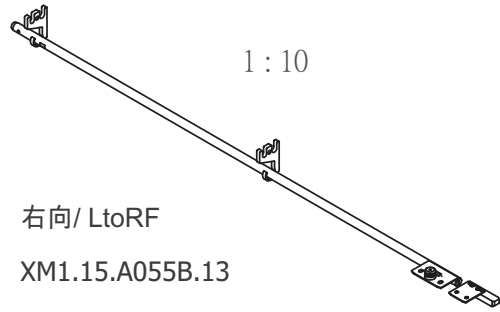

	Part Number	Descr.	Qty.
1	XM1.15.P002B.05		1
2	XM1.15.P008A.13		1
3	XM1.15.P055A.13		1
4	XM1.15.P004C.12		1
5	XM1.15.P005B		1
6	7380.05.08	SCREW ISO 7380	1
7	1481.04.12	STRAIGHT PIN ISO 8752	3
8	7991.03.08	SCREW ISO 10642	2
9	1481.03.10	STRAIGHT PIN ISO 8752	2
10	XM1.15.P007C.13		2

B0

B0 = 1

搭配LNS中軸015.031.013/100
/ Be used with LNS rotating sleeve 015.031.013/100

GENERAL TOLERANCE							
1 - 4	± 0.05	± 0.1	17 - 63	± 0.2	± 0.3	251 - 1000	± 0.3 ± 0.8
5 - 16	± 0.07	± 0.2	64 - 250	± 0.2	± 0.5	>1001	± 0.8 ± 1

Our drawings/designs and their annexes remain our sole property and we confide them to the addressee's personal care. Nobody has the right-without our written authorization-to copy, reproduce, show or give them to third parties in收件人个人需求下, 我们透露我们的设计图面与它的附件, 但它们仍然是我们专属的财产。任何人无权在未取得我们的书面文字授权的情况下复制、再制、展示和提供它们给第三者。

DESCRIPTION : LNS - 短押棒組 - 右 - Ø13/ LNS - Short Pusher Set - LtoRF - Ø13

SCALE 1:2

GT 112-E
Pusher

MATERIAL	
SURFACE	
HARDNESS	
WEIGHT (Kg)	
DATE	2015.05.19 2017.06.21
DRAWN BY	Mike Huang Last modif.
ECN	ECN.XM1.064 B0



www.lns-group.com

TW

XM1.15.A055B.13

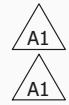
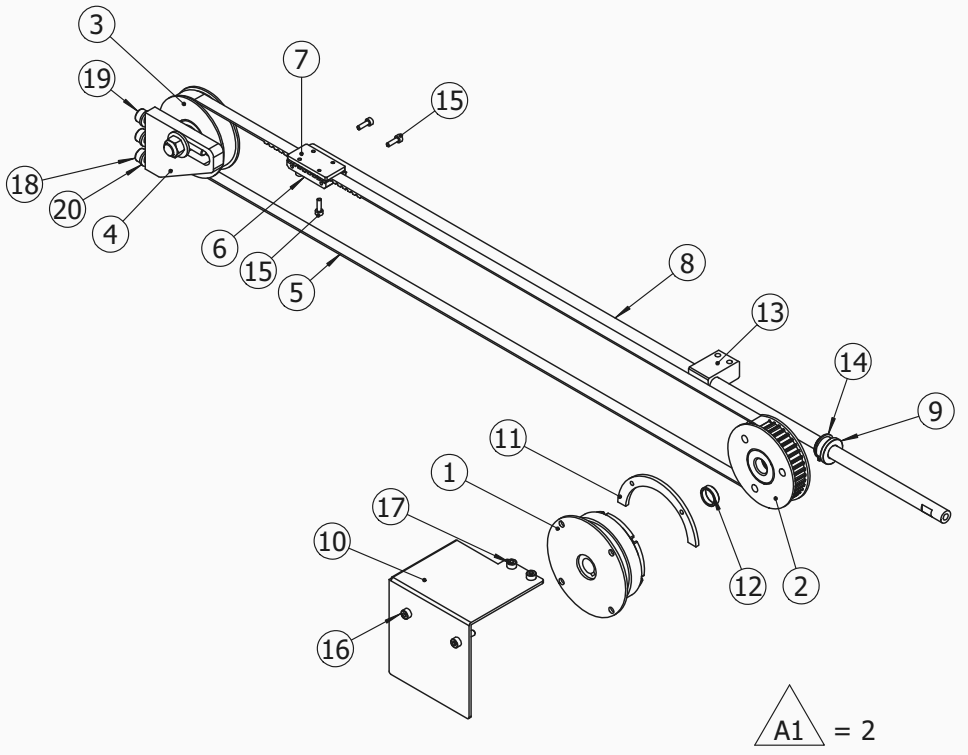
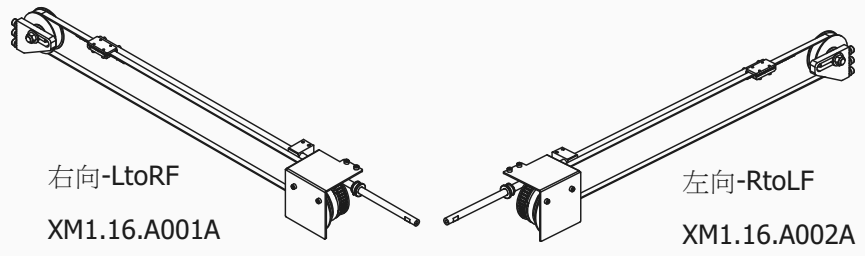

Item	Qty.	Part No.	Descr.
1	1	K16431200	
2	1	XM1.16.A003A	
3	1	XM1.16.A004A	
4	1	XM1.16.P001A	
5	1	XM1.16.P005B	
6	1	XM1.16.P006B	
7	1	XM1.16.P007B	
8	1	XM1.16.P008B	
9	1	XM1.16.P009B	
10	1	XM1.16.P010E	右 - LtoRF
10	1	XM1.16.P011E	左 - RtoLF
11	1	XM1.16.P012A	
12	1	XM1.16.P013A	
13	1	XM1.16.P016A	
14	1	Circlip DIN 471 - 16 x 1	
15	6	DIN 912 M3x10	
16	2	DIN 912 M4 x 16	
17	2	DIN 912 M4 x 8	
18	2	DIN 912 M6 x 16	
19	1	DIN 912 M6 x 60	
20	3	Washer DIN 125 - A 6.4	

△A1 = 2

DESCRIPTION: 同步組 - 右/ synchro set - LtoRF

SCALE 1:5

GT 112-E Synchronization

MATERIAL		
SURFACE		
HARDNESS		
WEIGHT (Kg)		
DATE	2014.06.25	2017.06.27
DRAWN BY	林義碧	Last modif.
ECN	ECN.XM1.065	A1

GENERAL TOLERANCE								
1 - 4	± 0.05	± 0.1	17 - 63	± 0.1	± 0.3	251 - 1000	± 0.3	± 0.8
5 - 16	± 0.07	± 0.2	64 - 250	± 0.2	± 0.5	>1001	± 0.8	± 1

Our drawings/designs and their annexes remain our sole property and we confide them to the addressee's personal care. Nobody has the right without our written authorization to copy, reproduce, show or give them to third parties in recipient's personal demand. 我們透露我們的设计圖面與它的附件，但它們仍然是我們專屬的財產。任何人無權在未獲得我們的書面文字授權的情況下复制、再制、展示和提供它們給第三者。



www.lns-group.com

TW

XM1.16.A001A

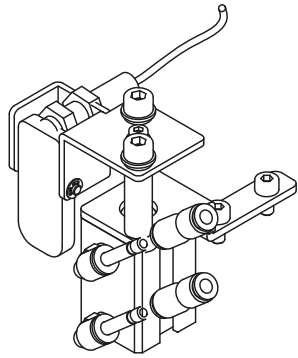

右向 - LtoRF
XM1.21.A001A

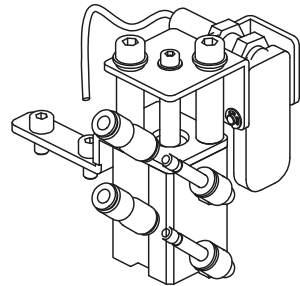

左向 - RtoLF
XM1.21.A002A

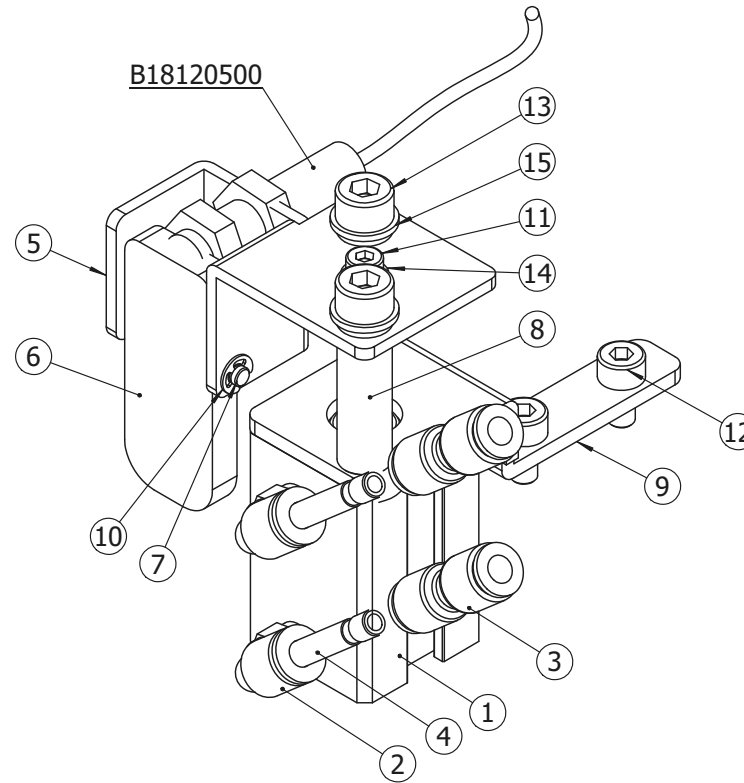

Item	Qty.	Part No.	Descr.
1	1	C12115300	
2	2	C13111000	
3	2	C13130900	
4	2	ST3401500	
5	1	XM1.21.P001C	右 - LtoRF
5	1	XM1.21.P002C	左 - RtoLF
6	1	XM1.21.P003B	
7	1	XM1.21.P004B	
8	2	XM1.21.P005C	
9	1	XM1.21.P006C	右 - LtoRF
9	1	XM1.21.P007C	左 - RtoLF
10	2	B27.7M - 3CM1-3	
11	1	DIN 912 M3 x 8	
12	2	DIN 912 M4 x 8	
13	2	DIN 912 M5 x 40	
14	1	Washer DIN 125 - A 3.2	
15	2	Washer DIN 125 - A 5.3	

GENERAL TOLERANCE

1 - 4	± 0.05	± 0.1	17 - 63	± 0.1	± 0.3	251 - 1000	± 0.3	± 0.8
5 - 16	± 0.07	± 0.2	64 - 250	± 0.2	± 0.5	>1001	± 0.8	± 1

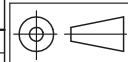

Our drawings/designs and their annexes remain our sole property and we confide them to the addressee's personal care. Nobody has the right-without our written authorization-to copy, reproduce, show or give them to third parties in收件人个人需求下, 我们透露我们的设计图面与它的附件, 但它们仍然是我们专属的财产。任何人无权在未获得我们的书面文字授权的情况下复制、再制、展示和提供它们给第三者。

DESCRIPTION : 切端組 - 右/ measurement - LtoRF

GT 112-E Measurement



www.lns-group.com

TW

SCALE	1:1	
MATERIAL		
SURFACE		
HARDNESS		
WEIGHT (Kg)		
DATE	2014.06.25	
DRAWN BY	林義碧	Last modif.
ECN	XM1-001	

XM1.21.A001A

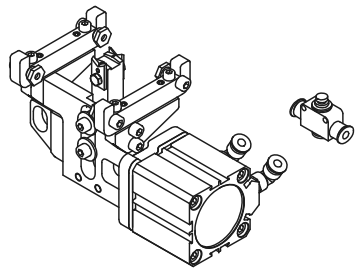

右向 - LtoRF
XM1.22.A001B

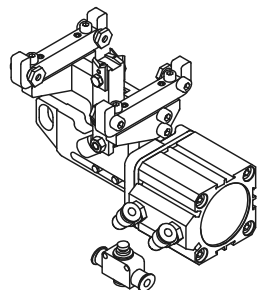
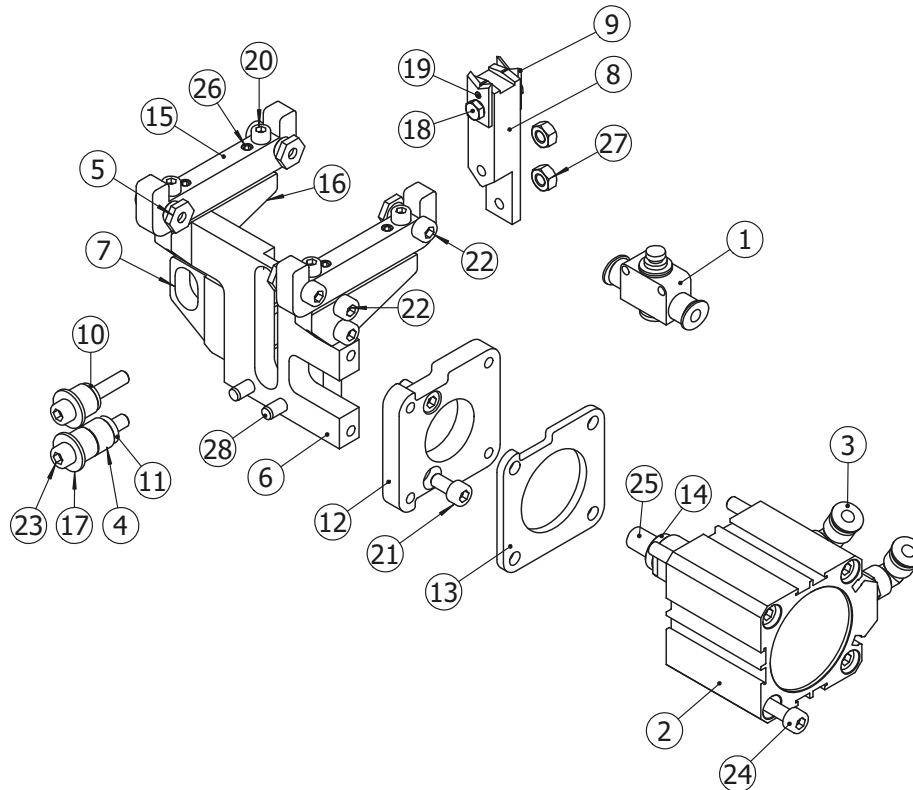

左向 - RtoLF
XM1.22.A002B

$\triangle B = 7$

Item	Qty.	Part No.	Descr.
1	1	C11130400	
2	1	C12110200	
3	2	C13110100	
4	3	F-16807	
5	4	XH14107000000	
$\triangle B$	6	1	XM1.22.P001C 右-LtoRF
$\triangle B$	6	1	XM1.22.P002C 左-RtoLF
$\triangle B$	7	1	XM1.22.P003D
8	1	XM1.22.P004E	
$\triangle B$	9	2	XM1.22.P005C
$\triangle B$	10	1	XM1.22.P006D
$\triangle B$	11	1	XM1.22.P007D
12	1	XM1.22.P008B	
13	1	XM1.22.P023A	
14	1	XM1.22.P024B	
$\triangle B$	15	2	XM1.22.P027A
$\triangle B$	16	2	XM1.22.P028A
17	2	9021.06	
18	2	933.05.08.Z	
19	2	DIN 6325.03.06.m6	
20	4	DIN 912 M5 x 25	
21	2	DIN 912 M6 x 12	
22	8	DIN 912 M6 x 16	
23	2	DIN 912 M6 x 35	
24	4	DIN 912 M6 x 65 --- 24N	
25	1	DIN 913 - M10 x 30-N_BLACK	
26	4	DIN 913 - M6 x 16	
27	2	Nut_DIN 934 M6	
28	2	Pin-6x24	

DESCRIPTION : 下夾座 - 右/ lower clamp - LtoRF

GT 112-E Vice

SCALE **1:3**

MATERIAL

SURFACE

HARDNESS

WEIGHT (Kg)

DATE

2014.06.25

2014.10.28

DRAWN BY

林義碧

Last modif.

ECN

XM1.22.A001B

GENERAL TOLERANCE

1 - 4	± 0.05	± 0.1	17 - 63	± 0.1	± 0.3	251 - 1000	± 0.3	± 0.8
5 - 16	± 0.07	± 0.2	64 - 250	± 0.2	± 0.5	>1001	± 0.8	± 1

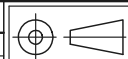

Our drawings/designs and their annexes remain our sole property and we confide them to the addressee's personal care. Nobody has the right without our written authorization to copy, reproduce, show or give them to third parties in收件人个人需求下, 我们透露我们的设计图面与它的附件, 但它们仍然是我们专属的财产。任何人无权在未获得我们的书面文字授权的情况下复制、再制、展示和提供它们给第三者。



www.lns-group.com

TW

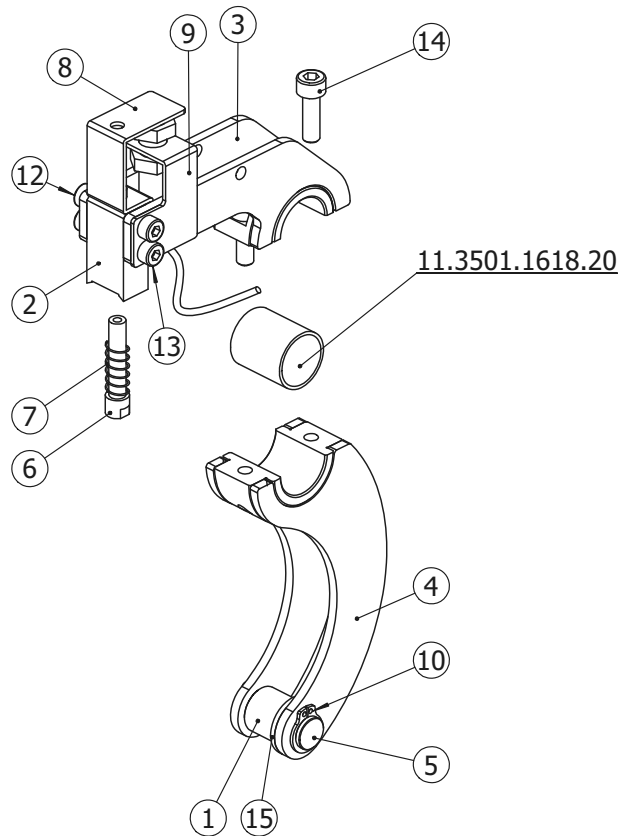

Item	Qty.	Part No.	Descr.
1	1	ST4100700	
2	1	XM1.22.P010C	
3	1	XM1.22.P013C	
4	1	XM1.22.P016B	
5	1	XM1.22.P017A	
6	1	XM1.22.P018A	
7	1	XM1.22.P019B	
A1	8	XM1.22.P020B	
A1	9	XM1.22.P021B	
10	2	Circlip DIN 471 - 10 x 1	
11	1	DIN 912 M3 x 6	
12	2	DIN 912 M4 x 6	
13	2	DIN 912 M4 x 8	
14	2	DIN 912 M5 x 16	
15	1	Washer DIN433-10.5_ELEC	

A1 = 2

DESCRIPTION : 上夾頭/ upper clamp

SCALE	1:2	
MATERIAL		
SURFACE		
HARDNESS		
WEIGHT (Kg)		
DATE	2014.06.25	2015.10.07
DRAWN BY	林義碧	Last modif.
ECN	ECN.XM1.024	A1

GT 112-E Vice

GENERAL TOLERANCE								
1 - 4	± 0.05	± 0.1	17 - 63	± 0.1	± 0.3	251 - 1000	± 0.3	± 0.8
5 - 16	± 0.07	± 0.2	64 - 250	± 0.2	± 0.5	>1001	± 0.8	± 1

Our drawings/designs and their annexes remain our sole property and we confide them to the addressee's personal care. Nobody has the right without our written authorization to copy, reproduce, show or give them to third parties. 在收件人个人需求下, 我们透露我们的设计图面与它的附件, 但它们仍然是我们专属的财产。任何人无权在未取得我们的书面文字授权的情况下复制、再制、展示和提供它们给第三者。



www.lns-group.com

TW

XM1.22.A003A

Item	Qty.	Part No.	Descr.
1	1	C11121500	
2	2	C13110100	
3	1	XM1.22.P025A	右 - LtoRF
3	1	XM1.22.P026A	左 - RtoLF

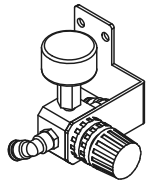

右向 - LtoRF
XM1.22.A004A

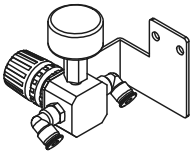
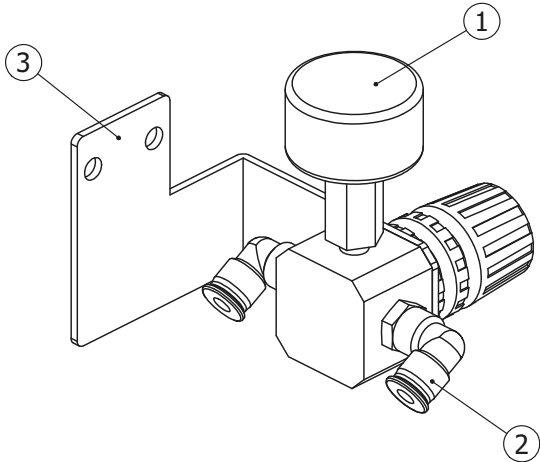

左向 - RtoLF
XM1.22.A005A

DESCRIPTION: 調壓閥組 - 右/ Regulator Set - LtoRF

SCALE	1:2	
MATERIAL		
SURFACE		
HARDNESS		
WEIGHT (Kg)		
DATE	2014.06.25	
DRAWN BY	林義碧	Last modif.
ECN	XM1-001	

GT 112-E
Vice

GENERAL TOLERANCE								
1 - 4	± 0.05	± 0.1	17 - 63	± 0.1	± 0.3	251 - 1000	± 0.3	± 0.8
5 - 16	± 0.07	± 0.2	64 - 250	± 0.2	± 0.5	>1001	± 0.8	± 1

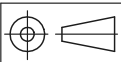

Our drawings/designs and their annexes remain our sole property and we confide them to the addressee's personal care. Nobody has the right without our written authorization to copy, reproduce, show or give them to third parties. 在收件人个人需求下, 我们透露我们的设计图面与它的附件, 但它们仍然是我们专属的财产。任何人无权在未获得我们的书面文字授权的情况下复制、再制、展示和提供它们给第三者。



www.lns-group.com

TW

XM1.22.A004A

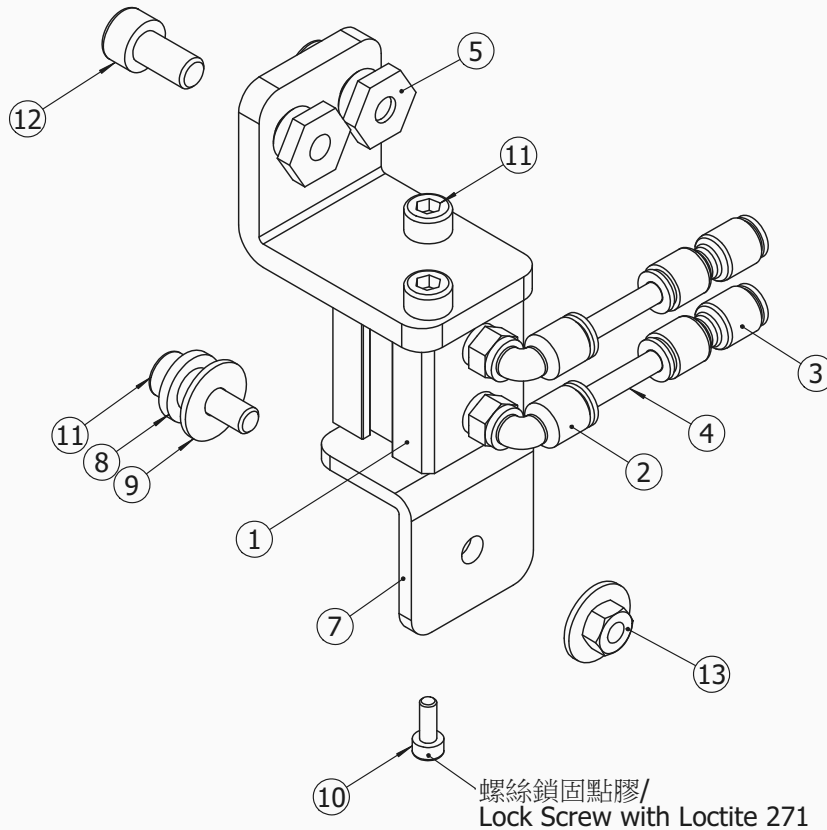

Item	Qty.	Part No.	Descr.
1	1	C12114800	
2	2	C13111000	
3	2	C13130900	
4	2	ST3401500	
5	2	XH14107000000	
6	1	XM1.22.P032B	
7	1	XM1.22.P033B	
8	1	XM1.22.P035A	
9	2	9021.05	
10	1	912.03.08.Z	
11	3	912.05.16.Z	
12	2	912.06.12.Z	
13	1	934.05.Z	

螺絲鎖固點膠/
Lock Screw with Loctite 271

DESCRIPTION: 插拔料離合器/ booster clutch

SCALE	1:1.2	
MATERIAL		
SURFACE		
HARDNESS		
WEIGHT (Kg)		
DATE	2017.06.02	
DRAWN BY	林義碧	Last modif.
ECN	ECN.XM1.058	

GT 112-E Insert-Extract



www.lns-group.com

TW

XM1.22.A006A

GENERAL TOLERANCE							
1 - 4	± 0.05	± 0.1	17 - 63	± 0.1	± 0.3	251 - 1000	± 0.3 ± 0.8
5 - 16	± 0.07	± 0.2	64 - 250	± 0.2	± 0.5	>1001	± 0.8 ± 1

Our drawings/designs and their annexes remain our sole property and we confide them to the addressee's personal care. Nobody has the right without our written authorization to copy, reproduce, show or give them to third parties. 在收件人个人需求下, 我们透露我们的设计图面与它的附件, 但它们仍然是我们专属的财产。任何人无权在未取得我们的书面文字授权的情况下复制、再制、展示和提供它们给第三者。

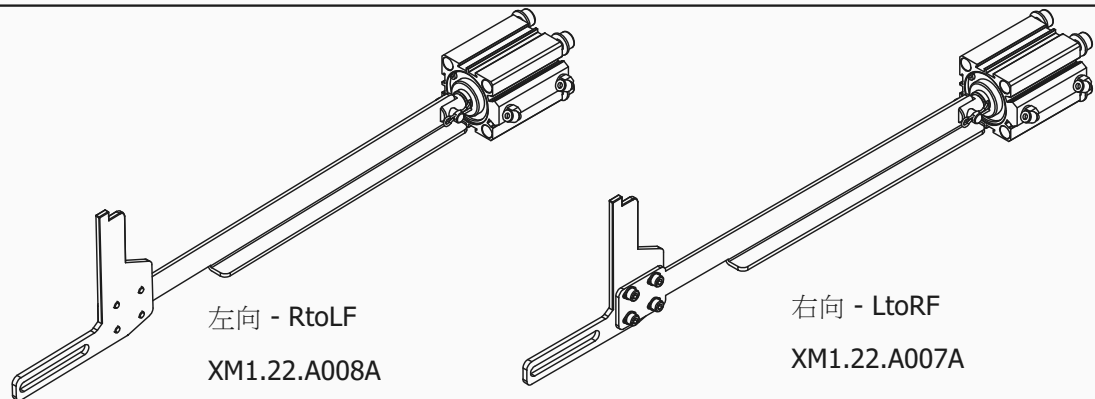

Item	Qty.	Part No.	Descr.
1	1	C12115700	
2	2	C13110301	
3	1	XM1.22.P029C	
4	1	XM1.22.P030B	
5	1	XM1.22.P031B	
6	1	XM1.22.P034C	
7	4	125A.05	
8	4	125A.08	
9	4	912.05.10.Z	
10	4	912.08.25.Z	
11	1	SSP-8-R-clip	

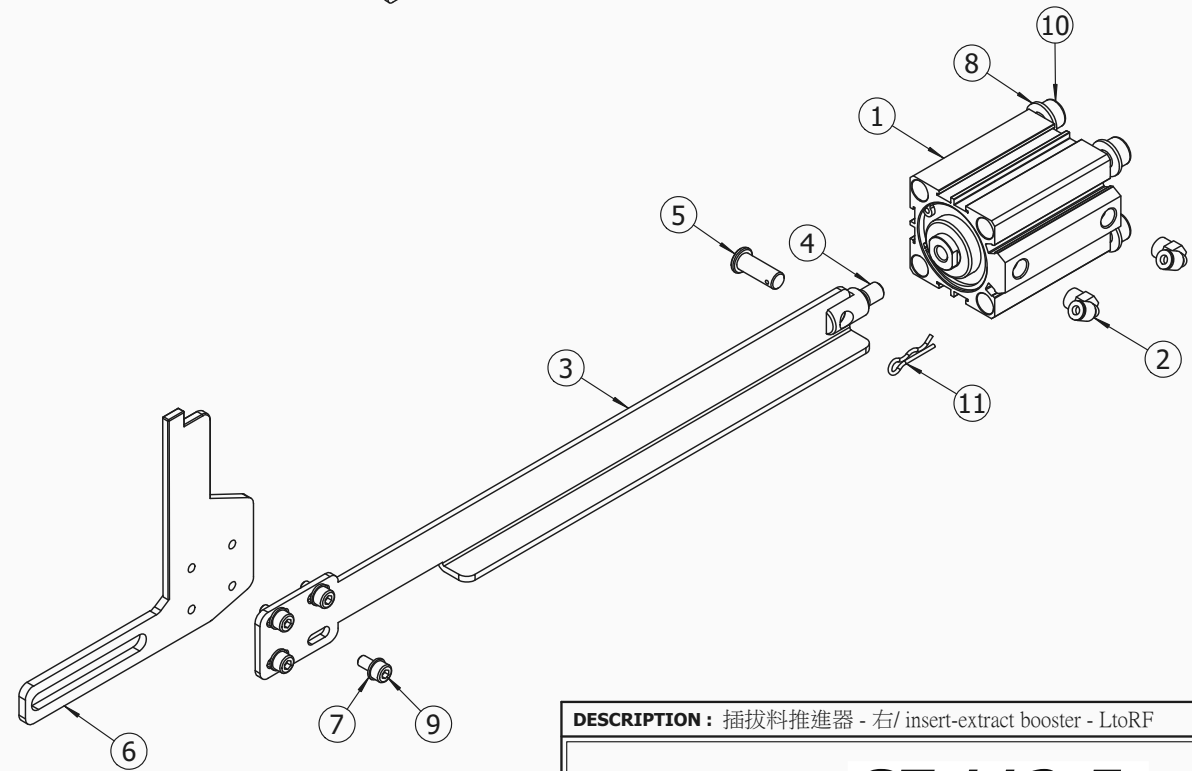

DESCRIPTION: 插拔料推進器 - 右/ insert-extract booster - LtoRF		SCALE	1:3
GT 112-E Insert-Extract		MATERIAL	
		SURFACE	
		HARDNESS	
		WEIGHT (Kg)	
		DATE	2017.06.02
		DRAWN BY	林義碧 Last modif.
		ECN	ECN.XM1.058
		XM1.22.A007A	

GENERAL TOLERANCE							
1 - 4	± 0.05	± 0.1	17 - 63	± 0.1	± 0.3	251 - 1000	± 0.3 ± 0.8
5 - 16	± 0.07	± 0.2	64 - 250	± 0.2	± 0.5	>1001	± 0.8 ± 1

Our drawings/designs and their annexes remain our sole property and we confide them to the addressee's personal care. Nobody has the right without our written authorization to copy, reproduce, show or give them to third parties. 在收件人个人需求下, 我们透露我们的设计图面与它的附件, 但它们仍然是我们专属的财产。任何人无权在未取得我们的书面文字授权的情况下复制、再制、展示和提供它们给第三者。



www.lns-group.com

TW

右向 - LtoRF
XM1.27.A501B

左向 - RtoLF
XM1.27.A502B

Item	Qty.	Part No.	Descr.
B 1	9	C11110100	
B 2	1	C11110114	
3	1	C11110200	
4	1	C11111200	
5	1	C11121400	
6	2	C13110401	
B 7	2	C13110500	
B 8	9	C13110800	
B 9	9	C13110900	
B 10	1	C13112300	
11	2	C14110100	
12	2	C14120200	

二次防震 / 透明
Second front rest (option)

閉蓋 / 藍
Channel Close

料蓋-5 / 藍
Upper cover

料蓋-4 / 藍
Upper cover

料蓋-3 / 藍
Upper cover

料蓋-2 / 藍
Upper cover

料蓋-1 / 藍
Upper cover

開蓋 / 藍
Channel Open

夾料 / 紅
Clamping

切端 / 灰
Measurement

插拔料離合器 / 綠
Booster clutch

插拔料推進器 / 黑
Insert-extract booster

△ B = 8 此電磁閥組與4.0M共用

DESCRIPTION: 電磁閥組 - 12' - 右 / electrical pneumatic - 12' - LtoRF

GT 112-E
Electrical Pneumatic

SCALE		1:3	
MATERIAL			
SURFACE			
HARDNESS			
WEIGHT (Kg)			
DATE	2016.01.18	2017.06.02	
DRAWN BY	林義碧	Last modif.	
ECN	ECN.XM1.058		

www.lns-group.com

XM1.27.A501B

GENERAL TOLERANCE							
1 - 4	± 0.05	± 0.1	17 - 63	± 0.1	± 0.3	251 - 1000	± 0.3 ± 0.8
5 - 16	± 0.07	± 0.2	64 - 250	± 0.2	± 0.5	>1001	± 0.8 ± 1

Our drawings/designs and their annexes remain our sole property and we confide them to the addressee's personal care. Nobody has the right without our written authorization to copy, reproduce, show or give them to third parties in recipient's personal demand. 我們透露我們的设计圖面與它的附件，但它們仍然是我們專屬的財產。任何人無權在未取得我們的書面文字授權的情況下复制、再制、展示和提供它們給第三者。



www.lns-group.com

TW

Item	Qty.	Part No.	Descr.
1	2	XM1.31.P019D	
2	1	XM1.31.P033A.11	
3	1	XM1.31.P034A.11	
4	10	DIN 7991 - M3 x 8	

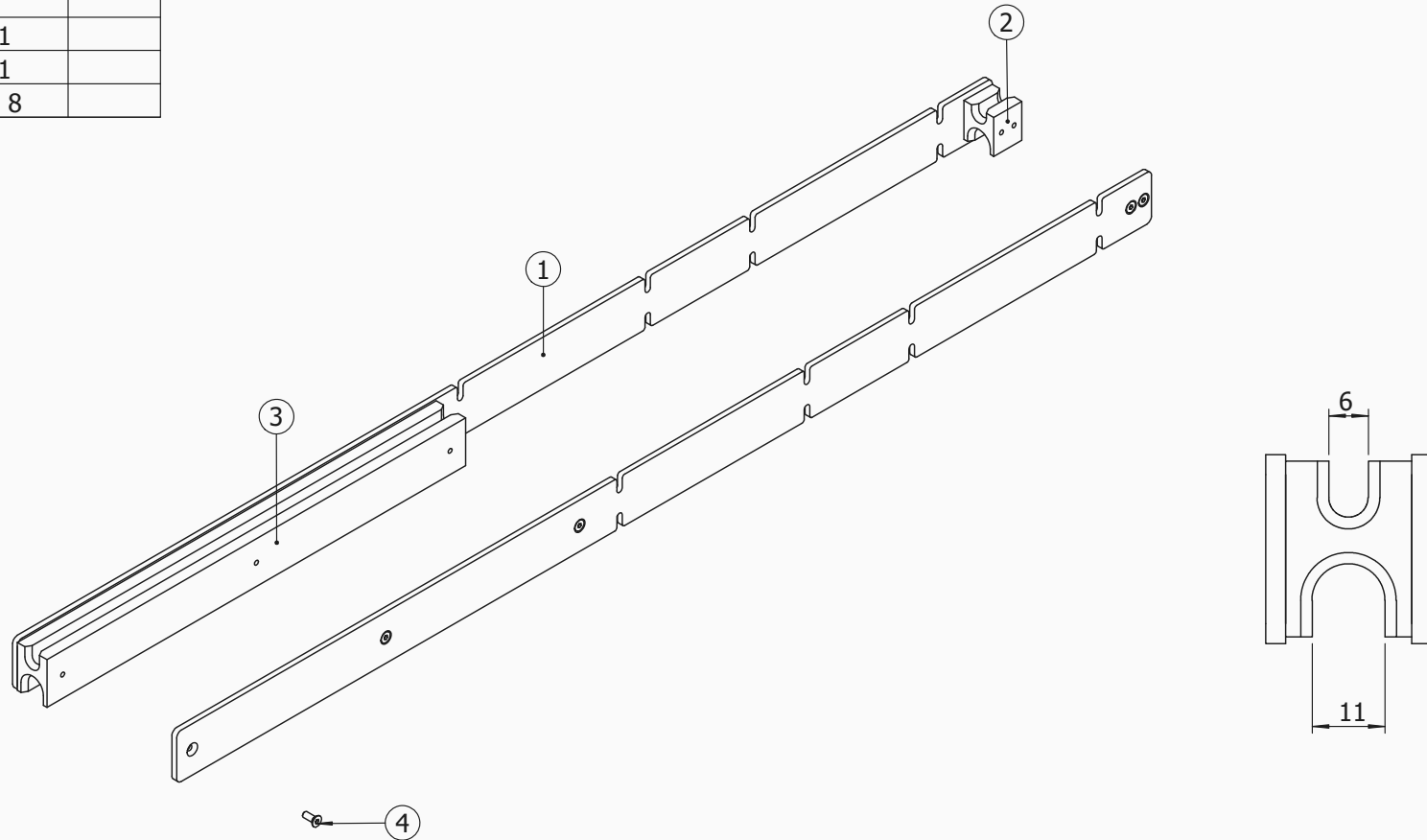

DESCRIPTION : 中段料管組 - 6/11/ middle channel set - 6/11

SCALE 1:3

GT 112-E Channel

MATERIAL

SURFACE

HARDNESS

WEIGHT (Kg)

DATE

2017.08.16

DRAWN BY

林義碧

Last modif.

ECN

ECN.XM1.060

XM1.31.A001A.11

GENERAL TOLERANCE

1 - 4	± 0.05	± 0.1	17 - 63	± 0.1	± 0.3	251 - 1000	± 0.3	± 0.8
5 - 16	± 0.07	± 0.2	64 - 250	± 0.2	± 0.5	>1001	± 0.8	± 1

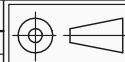

Our drawings/designs and their annexes remain our sole property and we confide them to the addressee's personal care. Nobody has the right without our written authorization to copy, reproduce, show or give them to third parties in recipient's personal demand. 我们透露我们的设计图面与它的附件，但它们仍然是我们专属的财产。任何人无权在未取得我们的书面文字授权的情况下复制、再制、展示和提供它们给第三者。



www.lns-group.com

TW

Item	Qty.	Part No.	Descr.
1	1	XM1.31.A001A.08	
2	1	XM1.31.A003A.06	
3	1	XM1.31.A003A.08	
4	2	XM1.31.P003C.08	
5	1	XM1.31.P013C.08	
$\triangle B$ 6	12	XM1.31.P022A.07	
7	1	XM1.31.P201A.08	

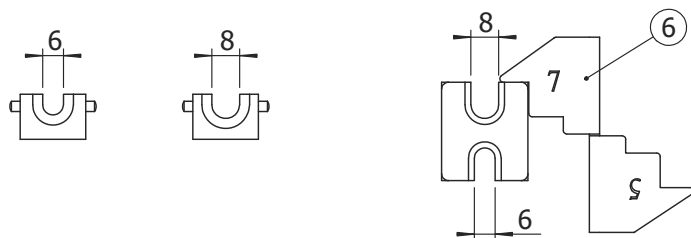
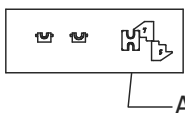
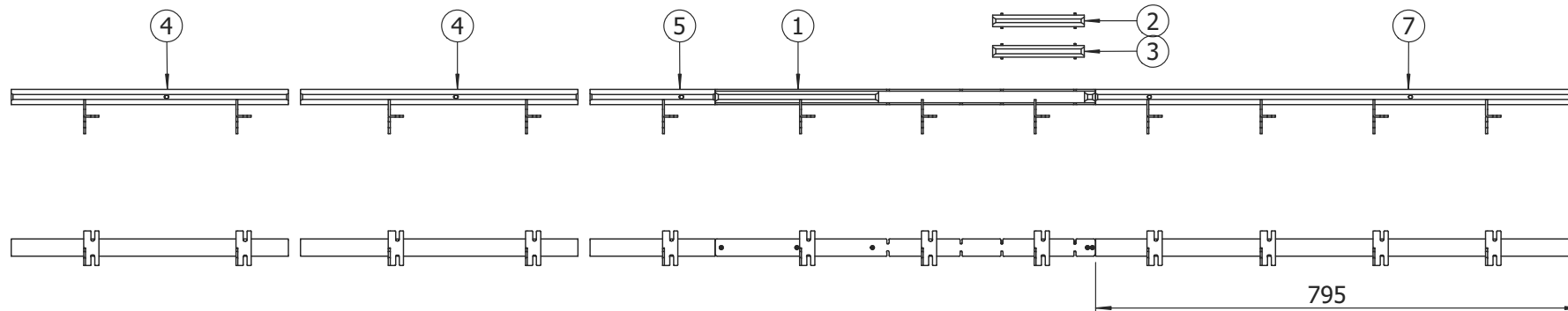

$\triangle B = 1$

A (1 : 2)

DESCRIPTION : 料管組 - 2.0M - 右 - 6/8/ channel set - 2.0M - LtoRF - 6/8

SCALE **1:10**

GT 112-E Channel

MATERIAL

SURFACE

HARDNESS

WEIGHT (Kg)

DATE 2014.06.25 2014.12.23

DRAWN BY 林義碧 Last modif.

ECN ECN.XM1.010

XM1.31.A201B.08

GENERAL TOLERANCE							
1 - 4	± 0.05	± 0.1	17 - 63	± 0.2	± 0.3	251 - 1000	± 0.3 ± 0.8
5 - 16	± 0.07	± 0.2	64 - 250	± 0.2	± 0.5	>1001	± 0.8 ± 1

Our drawings/designs and their annexes remain our sole property and we confide them to the addressee's personal care. Nobody has the right without our written authorization to copy, reproduce, show or give them to third parties in收件人个人需求下, 我们透露我们的设计图面与它的附件, 但它们仍然是我们专属的财产。任何人无权在未取得我们的书面文字授权的情况下复制、再制、展示和提供它们给第三者。



www.lns-group.com

TW

Item	Qty.	Part No.	Descr.
1	1	XM1.31.A001A.08	
2	1	XM1.31.A003A.06	
3	1	XM1.31.A003A.08	
4	2	XM1.31.P003C.08	
5	1	XM1.31.P013C.08	
6	12	XM1.31.P023A.07	
7	1	XM1.31.P201A.08	

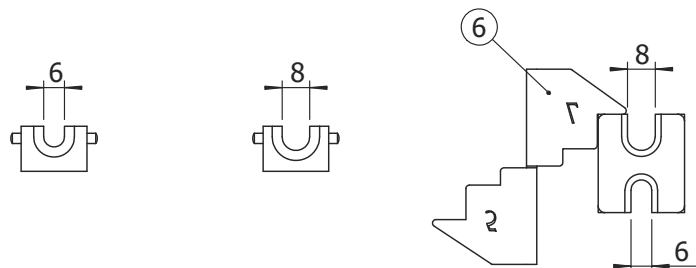
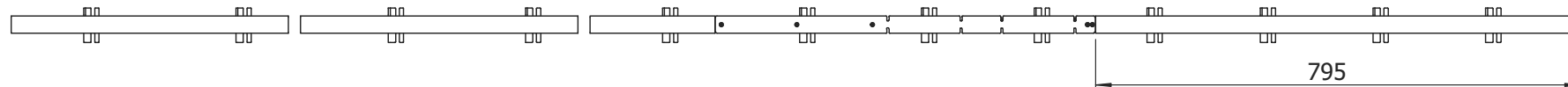
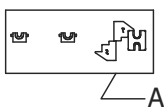
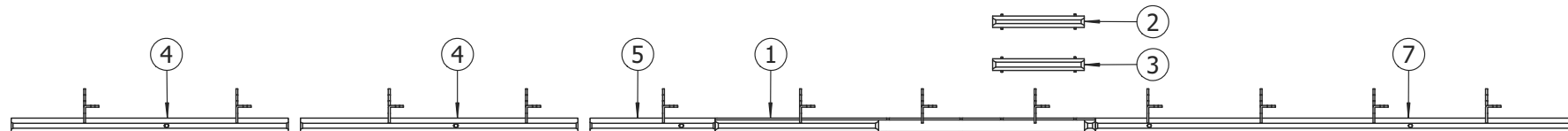

A (1 : 2)

DESCRIPTION : 料管組 - 2.0M - 左 - 6/8/ channel set - 2.0M - RtoLF - 6/8

SCALE 1:10

**GT 112-E
Channel**

MATERIAL

SURFACE

HARDNESS

WEIGHT (Kg)

DATE 2014.12.23

DRAWN BY 林義碧 Last modif.

ECN ECN.XM1.010

XM1.31.A203A.08

GENERAL TOLERANCE

1 - 4	± 0.05	± 0.1	17 - 63	± 0.1	± 0.3	251 - 1000	± 0.3	± 0.8
5 - 16	± 0.07	± 0.2	64 - 250	± 0.2	± 0.5	>1001	± 0.8	± 1

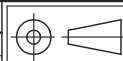

Our drawings/designs and their annexes remain our sole property and we confide them to the addressee's personal care. Nobody has the right without our written authorization to copy, reproduce, show or give them to third parties in recipient's personal demand. 我們透露我們的设计图面与它的附件, 但它们仍然是我们专属的财产。任何人无权在未获得我们的书面文字授权的情况下复制、再制、展示和提供它们给第三者。



www.lns-group.com

TW

Item	Qty.	Part No.	Descr.
1	1	XM1.31.A001A.11	
2	1	XM1.31.A003A.06	
3	2	XM1.31.P031A.11	
4	1	XM1.31.P032A.11	
5	21	XM1.31.P035A.10	
6	1	XM1.31.P502A.11	

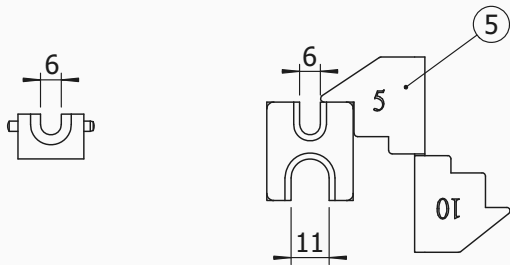
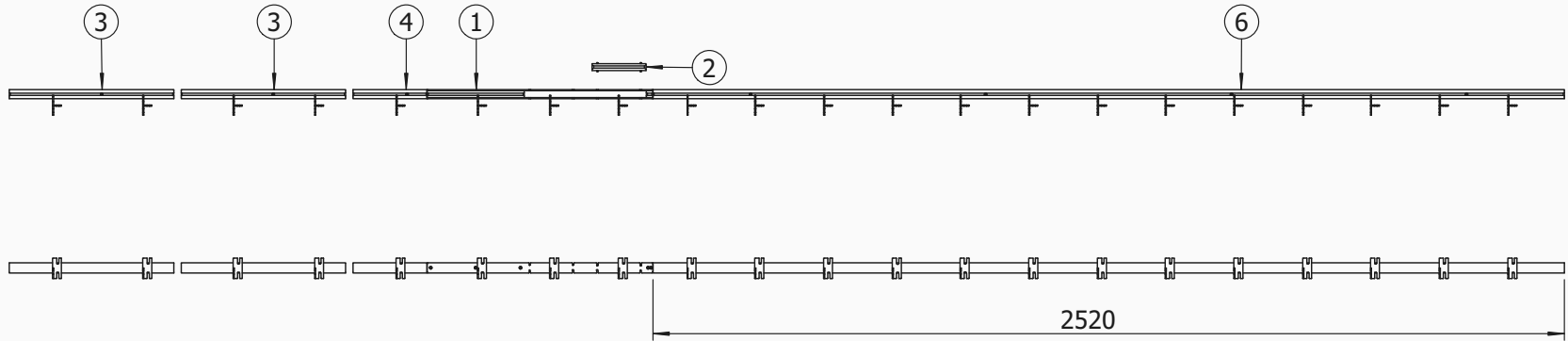

A (1 : 2)

GENERAL TOLERANCE							
1 - 4	± 0.05	± 0.1	17 - 63	± 0.2	± 0.3	251 - 1000	± 0.3 ± 0.8
5 - 16	± 0.07	± 0.2	64 - 250	± 0.2	± 0.5	>1001	± 0.8 ± 1

Our drawings/designs and their annexes remain our sole property and we confide them to the addressee's personal care. Nobody has the right without our written authorization to copy, reproduce, show or give them to third parties in recipient's personal demand. We disclose our design drawings with its annexes, but they remain our exclusive property. 任何人无权在未取得我们的书面文字授权的情况下复制、再制、展示和提供它们给第三者。

DESCRIPTION : 料管組 - 12' - 右 - 6/11/ channel set - 12' - LtoRF - 6/11

**GT 112-E
Channel**



www.lns-group.com

TW

SCALE	1:18	
MATERIAL		
SURFACE		
HARDNESS		
WEIGHT (Kg)		
DATE	2017.08.16	
DRAWN BY	林義碧	Last modif.
ECN	ECN.XM1.060	

XM1.31.A501A.11

Item	Qty.	Part No.	Descr.
1	1	XM1.31.A001A.11	
2	1	XM1.31.A003A.06	
3	2	XM1.31.P031A.11	
4	1	XM1.31.P032A.11	
5	12	XM1.31.P036A.10	
6	1	XM1.31.P202A.11	

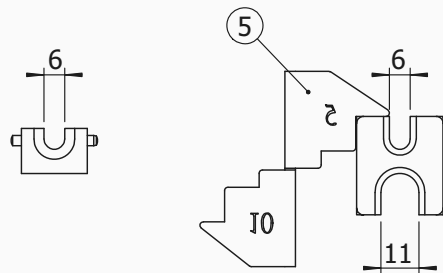
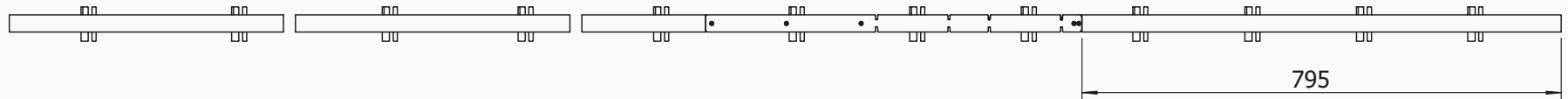
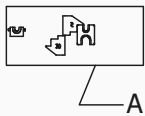
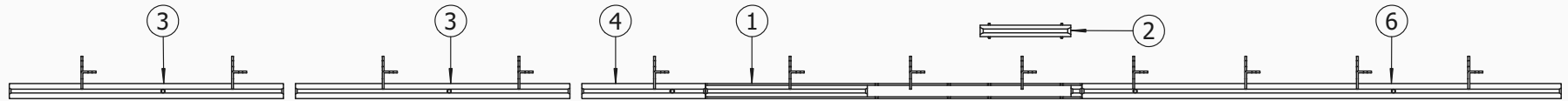

A (1 : 2)

DESCRIPTION : 料管組 - 2.0M - 左 - 6/11/ channel set - 2.0M -RtoLF - 6/11

SCALE	1:10	
MATERIAL		
SURFACE		
HARDNESS		
WEIGHT (Kg)		
DATE	2017.08.16	
DRAWN BY	林義碧	Last modif.
ECN	ECN.XM1.060	

**GT 112-E
Channel**

GENERAL TOLERANCE							
1 - 4	± 0.05	± 0.1	17 - 63	± 0.2	± 0.3	251 - 1000	± 0.3 ± 0.8
5 - 16	± 0.07	± 0.2	64 - 250	± 0.2	± 0.5	>1001	± 0.8 ± 1

Our drawings/designs and their annexes remain our sole property and we confide them to the addressee's personal care. Nobody has the right without our written authorization to copy, reproduce, show or give them to third parties in recipient's personal demand. We disclose our design drawings with its annexes, but they remain our exclusive property. Anyone is unauthorized to copy, reproduce, display and provide them to third parties without our written authorization.



www.lns-group.com

TW

XM1.31.A203A.11

Item	Qty.	Part No.	Descr.
1	1	XM1.31.A002A.13	
2	1	XM1.31.A003A.06	
3	2	XM1.31.P025A.13	
4	1	XM1.31.P026A.13	
$\triangle B$ 5	12	XM1.31.P029A.12	
6	1	XM1.31.P202A.13	

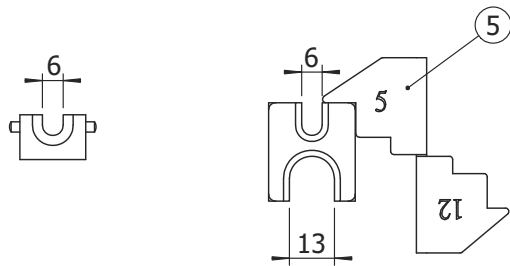
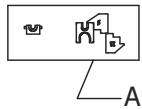
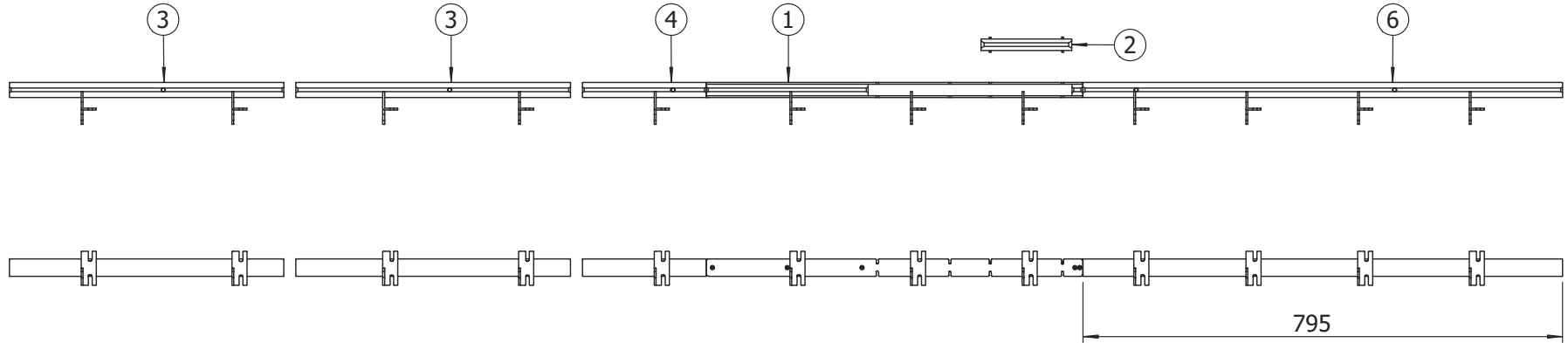

$\triangle B = 1$

A (1 : 2)

DESCRIPTION : 料管組 - 2.0M - 右 - 6/13/ channel set - 2.0M - LtoRF - 6/13

SCALE 1:10

**GT 112-E
Channel**

MATERIAL

SURFACE

HARDNESS

WEIGHT (Kg)

DATE

2014.06.25

2014.12.23

DRAWN BY

林義碧

Last modif.

ECN

ECN.XM1.010

XM1.31.A202B.13

GENERAL TOLERANCE							
1 - 4	± 0.05	± 0.1	17 - 63	± 0.2	± 0.3	251 - 1000	± 0.3 ± 0.8
5 - 16	± 0.07	± 0.2	64 - 250	± 0.2	± 0.5	>1001	± 0.8 ± 1

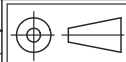

Our drawings/designs and their annexes remain our sole property and we confide them to the addressee's personal care. Nobody has the right without our written authorization to copy, reproduce, show or give them to third parties. 在收件人个人需求下, 我们透露我们的设计图面与它的附件, 但它们仍然是我们专属的财产。任何人无权在未取得我们的书面文字授权的情况下复制、再制、展示和提供它们给第三者。



www.lns-group.com

TW

Item	Qty.	Part No.	Descr.
1	1	XM1.31.A002A.13	
2	1	XM1.31.A003A.06	
3	2	XM1.31.P025A.13	
4	1	XM1.31.P026A.13	
5	12	XM1.31.P030A.12	
6	1	XM1.31.P202A.13	

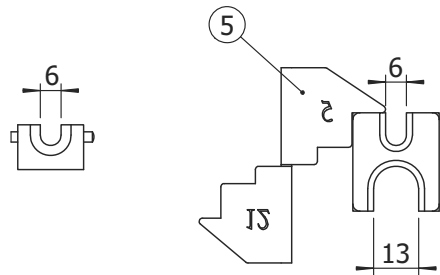
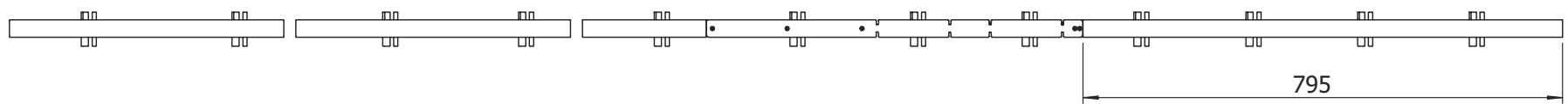
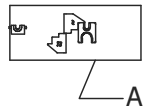
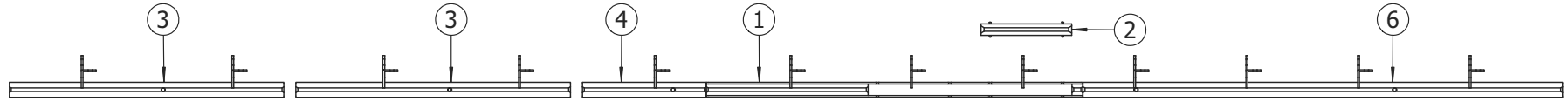

A (1 : 2)

GENERAL TOLERANCE

1 - 4	± 0.05	± 0.1	17 - 63	± 0.2	± 0.3	251 - 1000	± 0.3	± 0.8
5 - 16	± 0.07	± 0.2	64 - 250	± 0.2	± 0.5	>1001	± 0.8	± 1

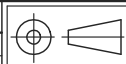

Our drawings/designs and their annexes remain our sole property and we confide them to the addressee's personal care. Nobody has the right without our written authorization to copy, reproduce, show or give them to third parties. 在收件人个人需求下，我们透露我们的设计图面与它的附件，但它们仍然是我们专属的财产。任何人无权在未取得我们的书面文字授权的情况下复制、再制、展示和提供它们给第三者。

DESCRIPTION : 料管組 - 2.0M - 左 - 6/13/ channel set - 2.0M - RtoLF - 6/13

**GT 112-E
Channel**



www.lns-group.com

TW

SCALE	1:10	
MATERIAL		
SURFACE		
HARDNESS		
WEIGHT (Kg)		
DATE	2014.12.23	
DRAWN BY	林義碧	Last modif.
ECN	ECN.XM1.010	

XM1.31.A204A.13

Item	Qty.	Part No.	Descr.
1	1	XM1.31.A001A.08	
2	1	XM1.31.A003A.06	
3	1	XM1.31.A003A.08	
4	2	XM1.31.P003C.08	
5	1	XM1.31.P013C.08	
6	21	XM1.31.P022A.07	
7	1	XM1.31.P501A.08	

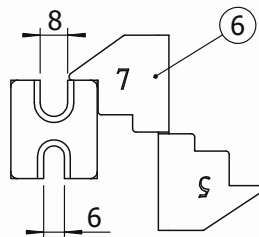
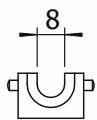
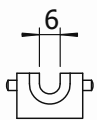
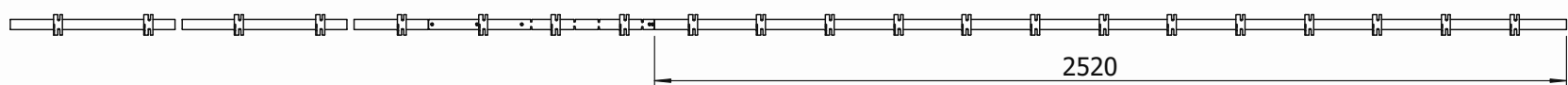
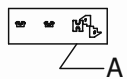
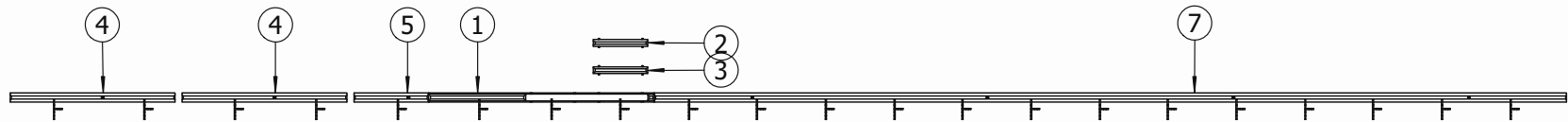

A (1 : 2)

DESCRIPTION : 料管組 - 12' - 右 - 6/8/ channel set - 12' - LtoRF - 6/8

SCALE **1:18**

**GT 112-E
Channel**

MATERIAL

SURFACE

HARDNESS

WEIGHT (Kg)

DATE

2016.01.18

DRAWN BY

林義碧

Last modif.

ECN

ECN.M1.031

A0

GENERAL TOLERANCE

1 - 4	± 0.05	± 0.1	17 - 63	± 0.1	± 0.3	251 - 1000	± 0.3	± 0.8
5 - 16	± 0.07	± 0.2	64 - 250	± 0.2	± 0.5	>1001	± 0.8	± 1

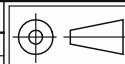

Our drawings/designs and their annexes remain our sole property and we confide them to the addressee's personal care. Nobody has the right without our written authorization to copy, reproduce, show or give them to third parties. 在收件人个人需求下, 我们透露我们的设计图面与它的附件, 但它们仍然是我们专属的财产。任何人无权在未获得我们的书面文字授权的情况下复制、再制、展示和提供它们给第三者。



www.lns-group.com

TW

XM1.31.A501A.08

Item	Qty.	Part No.	Descr.
1	1	XM1.31.A001A.08	
2	1	XM1.31.A003A.06	
3	1	XM1.31.A003A.08	
4	2	XM1.31.P003C.08	
5	1	XM1.31.P013C.08	
6	21	XM1.31.P023A.07	
7	1	XM1.31.P501A.08	

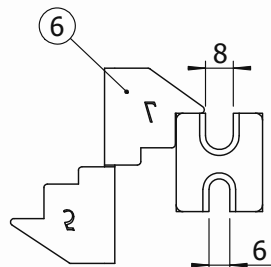
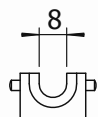
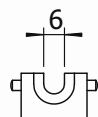
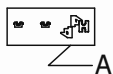
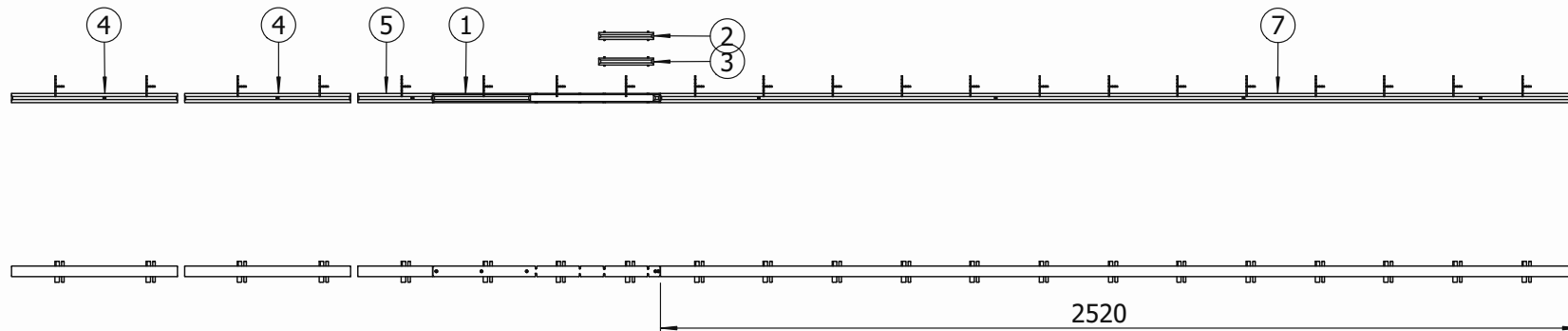

A (1 : 2)

DESCRIPTION : 料管組 - 12' - 左 - 6/8/ channel set - 12' - RtoLF - 6/8

SCALE **1:18**

**GT 112-E
Channel**

MATERIAL

SURFACE

HARDNESS

WEIGHT (Kg)

DATE 2016.01.18

DRAWN BY 林義碧 Last modif.

ECN ECN.XM1.031 A0

XM1.31.A503A.08

GENERAL TOLERANCE

1 - 4	± 0.05	± 0.1	17 - 63	± 0.2	± 0.3	251 - 1000	± 0.3	± 0.8
5 - 16	± 0.07	± 0.2	64 - 250	± 0.2	± 0.5	>1001	± 0.8	± 1

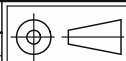

Our drawings/designs and their annexes remain our sole property and we confide them to the addressee's personal care. Nobody has the right without our written authorization to copy, reproduce, show or give them to third parties. 在收件人个人需求下, 我们透露我们的设计图面与它的附件, 但它们仍然是我们专属的财产。任何人无权在未获得我们的书面授权的情况下复制、再制、展示和提供它们给第三者。



www.lns-group.com

TW

Item	Qty.	Part No.	Descr.
1	1	XM1.31.A001A.11	
2	1	XM1.31.A003A.06	
3	2	XM1.31.P031A.11	
4	1	XM1.31.P032A.11	
5	21	XM1.31.P035A.10	
6	1	XM1.31.P502A.11	

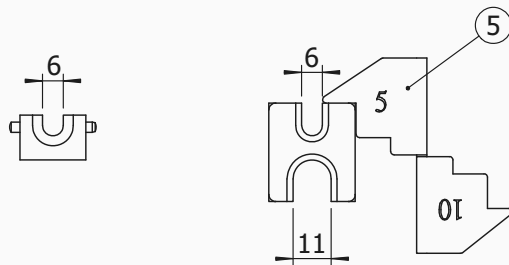
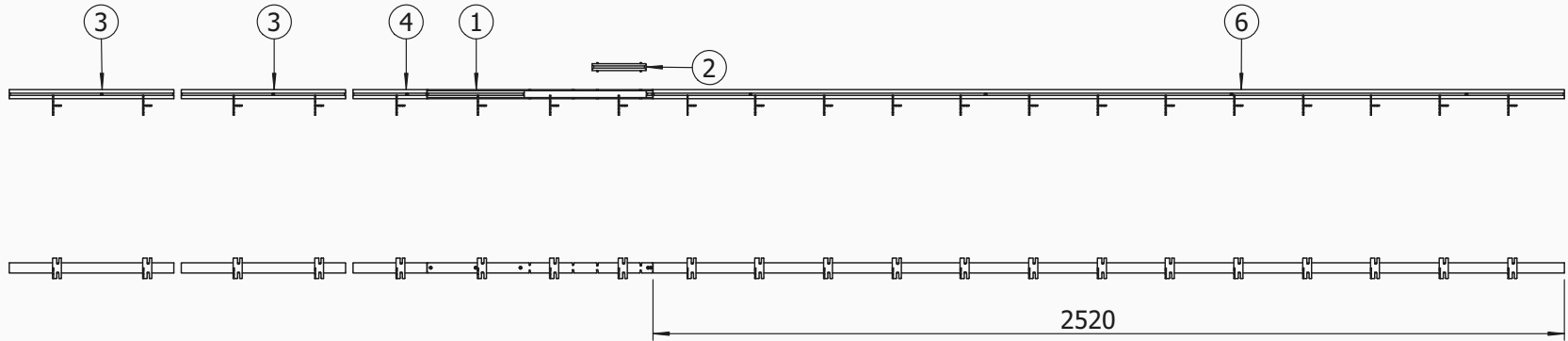

A (1 : 2)

DESCRIPTION : 料管組 - 12' - 右 - 6/11/ channel set - 12' - LtoRF - 6/11

SCALE **1:18**

GT 112-E
Channel

MATERIAL

SURFACE

HARDNESS

WEIGHT (Kg)

DATE

2017.08.16

DRAWN BY

林義碧

Last modif.

ECN

ECN.XM1.060

XM1.31.A501A.11

GENERAL TOLERANCE							
1 - 4	± 0.05	± 0.1	17 - 63	± 0.2	± 0.3	251 - 1000	± 0.3 ± 0.8
5 - 16	± 0.07	± 0.2	64 - 250	± 0.2	± 0.5	>1001	± 0.8 ± 1

Our drawings/designs and their annexes remain our sole property and we confide them to the addressee's personal care. Nobody has the right without our written authorization to copy, reproduce, show or give them to third parties. 在收件人个人需求下, 我们透露我们的设计图面与它的附件, 但它们仍然是我们专属的财产。任何人无权在未取得我们的书面文字授权的情况下复制、再制、展示和提供它们给第三者。



www.lns-group.com

TW

Item	Qty.	Part No.	Descr.
1	1	XM1.31.A001A.11	
2	1	XM1.31.A003A.06	
3	2	XM1.31.P031A.11	
4	1	XM1.31.P032A.11	
5	21	XM1.31.P036A.10	
6	1	XM1.31.P502A.11	

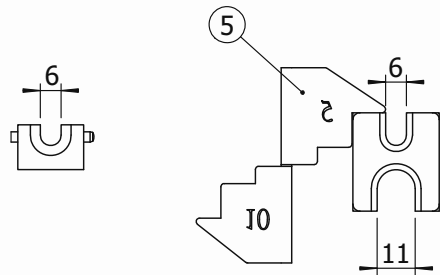
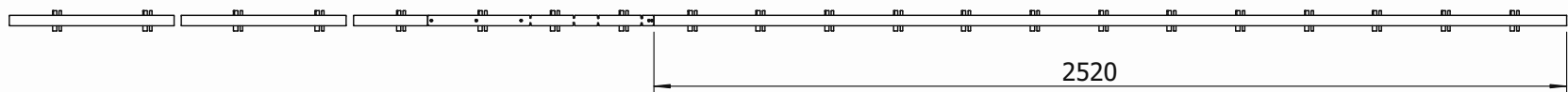

A (1 : 2)

DESCRIPTION : 料管組 - 12' - 左 - 6/11/ channel set - 12' - RtoLF - 6/11

SCALE 1:18

**GT 112-E
Channel**

MATERIAL

SURFACE

HARDNESS

WEIGHT (Kg)

DATE

2017.08.16

DRAWN BY

林義碧

Last modif.

ECN

ECN.XM1.060

XM1.31.A503A.11

GENERAL TOLERANCE								
1 - 4	± 0.05	± 0.1	17 - 63	± 0.1	± 0.3	251 - 1000	± 0.3	± 0.8
5 - 16	± 0.07	± 0.2	64 - 250	± 0.2	± 0.5	>1001	± 0.8	± 1

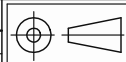

Our drawings/designs and their annexes remain our sole property and we confide them to the addressee's personal care. Nobody has the right without our written authorization to copy, reproduce, show or give them to third parties. 在收件人个人需求下, 我们透露我们的设计图面与它的附件, 但它们仍然是我们专属的财产。任何人无权在未获得我们的书面文字授权的情况下复制、再制、展示和提供它们给第三者。



www.lns-group.com

TW

Item	Qty.	Part No.	Descr.
1	1	XM1.31.A002A.13	
2	1	XM1.31.A003A.06	
3	2	XM1.31.P025A.13	
4	1	XM1.31.P026A.13	
5	21	XM1.31.P029A.12	
6	1	XM1.31.P502A.13	

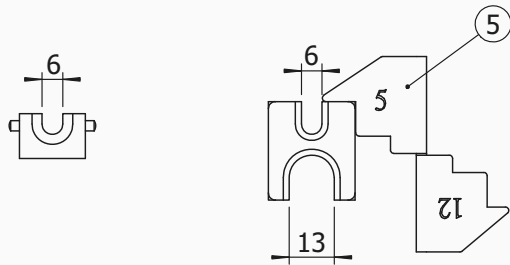
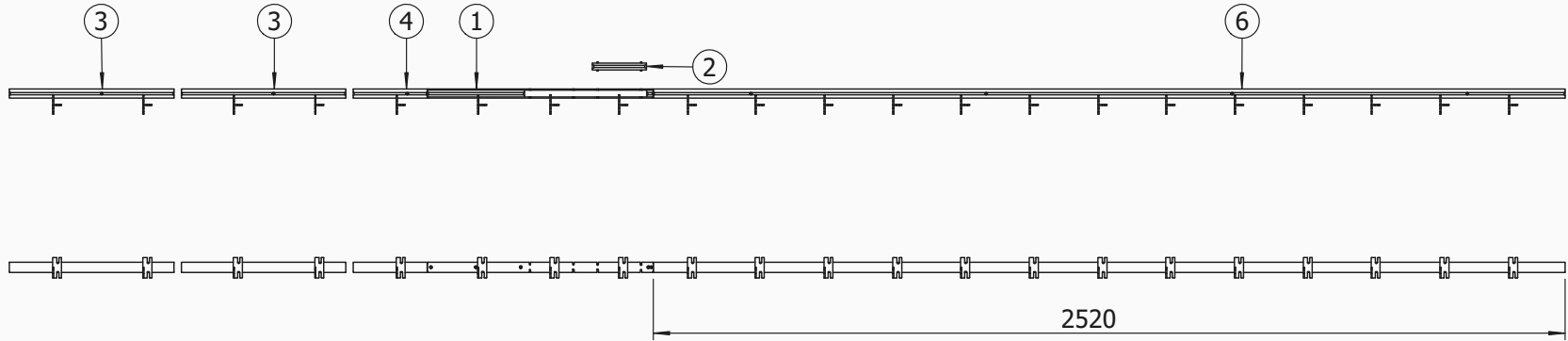

A (1 : 2)

DESCRIPTION : 料管組 - 12' - 右 - 6/13/ channel set - 12' - LtoRF - 6/13

**GT 112-E
Channel**

SCALE	1:18	
MATERIAL		
SURFACE		
HARDNESS		
WEIGHT (Kg)		
DATE	2016.01.18	
DRAWN BY	林義碧	Last modif.
ECN	ECN.XM1.031	A0

GENERAL TOLERANCE							
1 - 4	± 0.05	± 0.1	17 - 63	± 0.2	± 0.3	251 - 1000	± 0.3 ± 0.8
5 - 16	± 0.07	± 0.2	64 - 250	± 0.2	± 0.5	>1001	± 0.8 ± 1

Our drawings/designs and their annexes remain our sole property and we confide them to the addressee's personal care. Nobody has the right without our written authorization to copy, reproduce, show or give them to third parties in recipient's personal demand. We disclose our design drawings with its annexes, but they remain our exclusive property. Anyone is unauthorized to copy, reproduce, display and provide them to third parties without our written authorization.



www.lns-group.com

TW

XM1.31.A502A.13

Item	Qty.	Part No.	Descr.
1	1	XM1.31.A002A.13	
2	1	XM1.31.A003A.06	
3	2	XM1.31.P025A.13	
4	1	XM1.31.P026A.13	
5	21	XM1.31.P030A.12	
6	1	XM1.31.P502A.13	

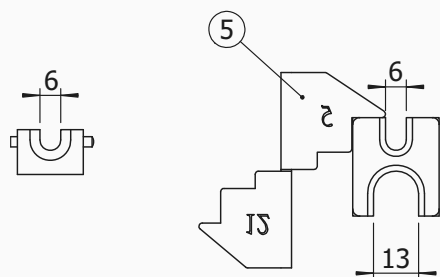
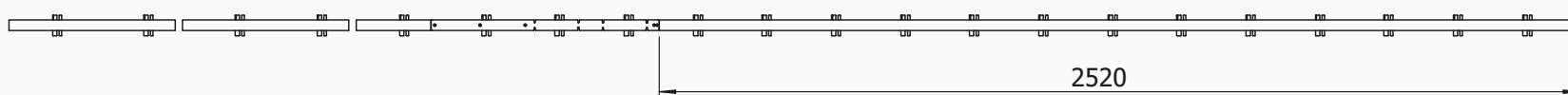

A (1 : 2)

DESCRIPTION : 料管組 - 12' - 左 - 6/13/ channel set - 12' - RtoLF - 6/13

SCALE **1:18**

**GT 112-E
Channel**

MATERIAL

SURFACE

HARDNESS

WEIGHT (Kg)

DATE

2016.01.18

DRAWN BY

林義碧

Last modif.

ECN

ECN.XM1.031

A0

XM1.31.A504A.13

GENERAL TOLERANCE

1 - 4	± 0.05	± 0.1	17 - 63	± 0.2	± 0.3	251 - 1000	± 0.3	± 0.8
5 - 16	± 0.07	± 0.2	64 - 250	± 0.2	± 0.5	>1001	± 0.8	± 1

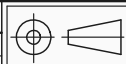

Our drawings/designs and their annexes remain our sole property and we confide them to the addressee's personal care. Nobody has the right without our written authorization to copy, reproduce, show or give them to third parties. 在收件人个人需求下, 我们透露我们的设计图面与它的附件, 但它们仍然是我们专属的财产。任何人无权在未获得我们的书面文字授权的情况下复制、再制、展示和提供它们给第三者。



www.lns-group.com

TW